

Pros and cons of characterising an optical translocation setup

Charles Maphanga^{1,2}, Rudzani Malabi^{1,2}, Saturnin Ombinda-Lemboumba¹, Malik Maaza²,
Patience Mthunzi-Kufa^{1,2*}

¹Council for Scientific and Industrial Research, National Laser Centre, P O BOX 395, Pretoria,
0001, South Africa

²College of Science, Engineering and Technology, Department of Physics, NB Pityana Building,
University of South Africa, Science Campus, Florida, 1710, South Africa

ABSTRACT

The delivery of genetic material and drugs into mammalian cells using femtosecond (fs) laser pulses is escalating rapidly. This novel light based technique achieved through a precise focusing of a laser beam on the plasma membrane is called photoporation. This technique is attained using ultrashort laser pulses to irradiate plasma membrane of mammalian cells, thus resulting in the accumulation of a vast amount of free electrons. These generated electrons react photo-chemically with the cell membrane, resulting in the generation of sub-microscopic pores on the cell membrane enabling a variety of extracellular media to diffuse into the cell. This study is aimed at critically analysing the “do’s and don’ts” of designing, assembling, and characterising an optical translocation setup using a femtosecond legend titanium sapphire regenerative amplifier pulsed laser (Gaussian beam, 800 nm, 1 kHz, 113 fs, and an output power of 850 mW). The main objective in our study is to determine optical phototranslocation parameters which are compatible to the plasma membrane and cell viability. Such parameters included beam profiling, testing a range of laser fluencies suitable for photoporation, assessment of the beam quality and laser-cell interaction time. In our study, Chinese Hamster Ovary-K1 (CHO-K1) cells were photoporated in the presence of trypan blue to determine optimal parameters for photoporation experiment. An average power of 4.5 μ W, exposure time of 7 ms, with a laser beam spot of \sim 1.1 μ m diameter at the focus worked optimally without any sign of cell stress and cytoplasmic bleeding. Cellular responses post laser treatment were analysed using cell morphology studies.

Keywords: Femtosecond laser, photoporation, ultrashort pulses, plasma membrane, sub-microscopic, Chinese Hamster Ovary, cell morphology

*pmthunzikufa@csir.co.za

1. INTRODUCTION

Various physical methods for localised delivery of exogenous material into mammalian cells have been developed over the years^[1]. These methods may be chemical i.e. via use of cationic polymers and lipids, or viral and physical methods including electroporation and microinjection^[1, 2]. Each of these methods has its own limitations, they are either extremely invasive with a risk of contamination or lack specificity^[1]. The introduction of exogenous material into cells is a challenging process in cell biology, most especially when it is required to target specific cells for treatment purposes especially in cancer studies since the conventional methods (e.g. liposomal transfection and electroporation) are designed to simultaneously target a population of cells rather than individual cells^[3]. Single-cell transfection (a method of introducing nucleic acids into cells to produce genetically modified cells) allows individual monitoring of targeted cells within a population, thus allowing genetic changes in that cell, and the untreated cells act as controls or indicators for successful transfection in the target cell populations^[4]. Generally, the ideal method to deliver exogenous material into cells should be easy to use, reproducible, have high transfection efficiency, minimal cell toxicity, high cell viability, minimal effects on normal physiology of the cell, and have low risk of contamination^[5].

New research developments on the use of light in cell biology have stretched from just using light for passive observation of cells through the microscope to manipulating cells through ablating, trapping, moving, cutting, stretching, spinning, and photoporation^[3, 6]. Photoporation has been demonstrated using various laser sources and the laser-cell interaction is dependent on the type of laser source used. Whilst, the mechanism of continuous wave (CW) lasers is based on thermal heating of the cell membrane to allow influx of exogenous matter which may result in cell death. The reaction of the cell to pulsed laser sources depends on the pulse duration which generates free electrons on the cell membrane resulting in the generation of a pore, however longer pulse durations may demonstrate thermal effects, bubble formation, and thermoelastic stresses which may damage the cell^[6]. Laser-assisted cell poration (photoporation) using a tightly focused femtosecond pulsed laser enables cell specificity during optical treatments through individual irradiation of cells. At optimum parameters, high transfection efficiency with low cell cytotoxicity and high cell viability can be achieved at low risk of contamination^[5]. In this study, a titanium sapphire regenerative amplifier femtosecond laser with high peak powers, low repetition rate (1 kHz), short pulse duration of ~113 fs, and 800 nm wavelength was used to phototranslocate trypan blue dye into Chinese Hamster Ovary (CHO) cells.

2. MATERIALS AND METHODS

2.1 The optical-translocation setup

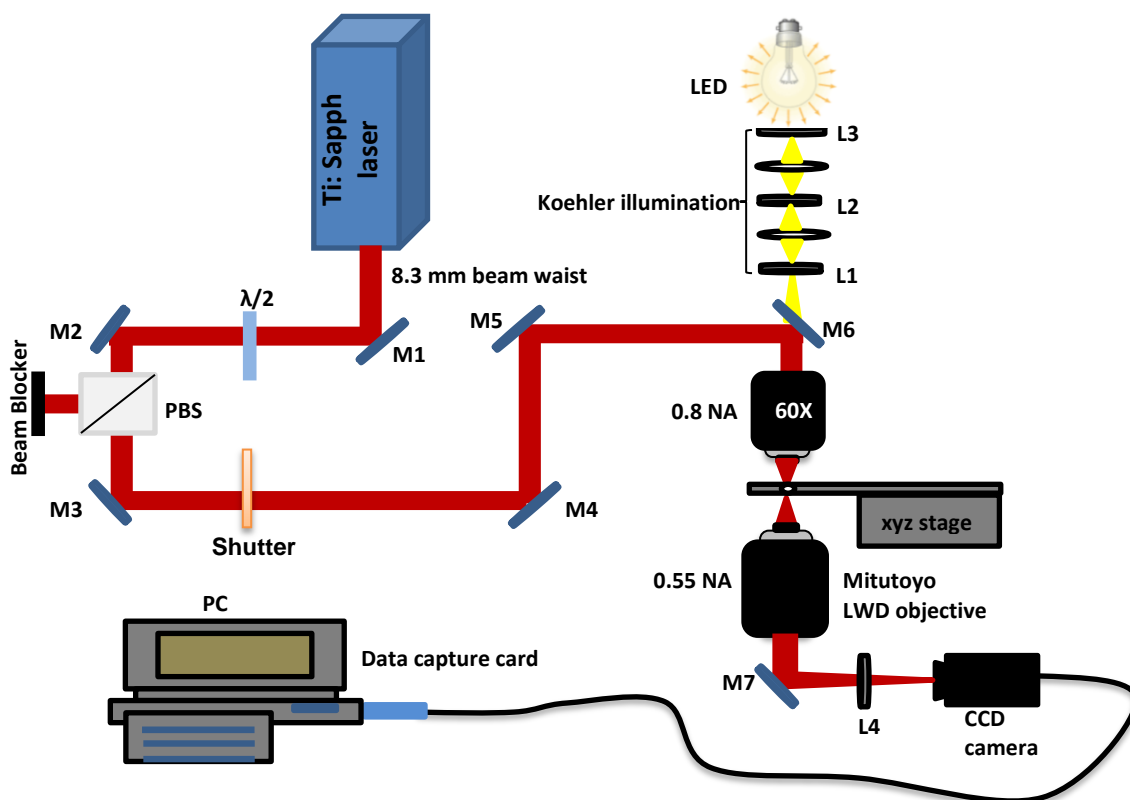

Figure 1: A schematic representation of the phototranslocation setup used to deliver trypan blue into CHO cells. A commercial titanium sapphire (Ti:Sapph) regenerative amplifier (RGA) laser was used to assemble a home-made optical setup. The RGA emitted an 8.3 mm Gaussian beam which was reflected by mirror 1 (M1) then passed through a half-wave plate ($\lambda/2$) to M2 through a cubed polarising beam splitter (PBS) to M3 and through an automated shutter to M4. M1 – M5 are near infrared (NIR) coated mirrors. Mirror 4 and 5 forms a periscope directing the beam to M6 which is a dichroic mirror crucial to reflect the beam to the back aperture of the 60x microscope objective at the same time allowing transmission of the Koehler illumination system.

The RGA emitted 8.3 mm Gaussian laser beam which was guided by five near infrared (NIR) coated mirrors (M1 – M5) as depicted on Fig 1. The laser light pulses were delivered at 800 nm wavelength, with pulse duration of 113 fs at 1 kHz repetition rate. Between M1 and M2, a half-wave plate was used in conjunction with the cubed PBS to attenuate the power at the sample plane. A neutral density (ND) filter(s) may be placed on the beam path before the shutter to reduce the power output. The automated shutter (Uniblitz electronics, LS6S2ZM1) between M3 and M4 was used to regulate the laser-cell interaction time to prevent cell damage. A 38% average power loss was calculated by measuring the power after the shutter and at the xyz-stage where the laser interacts with the cells. Mirror 4 and 5 formed a periscope which was used to elevate the beam from the optical table in order to reach the back aperture of the microscope objective. The measured diameter of the back aperture of the 60x microscope objective was 8.1 mm; therefore there was no need to expand the beam with a telescope because 8.3 mm beam emitted by the RGA could fill the back aperture of the microscope objective. Koehler illumination setup formed by a series of lenses and iris's played a crucial role for sample lighting on the xyz-stage. The sample imaging system was then formed by Koehler illumination system, 50x Mitutoyo long working distance objective with a focal length of 200 mm (NA = 0.55) and a charge-coupled device (CCD) camera (Watec, W96N15832) to visualise and record photoporation investigations.

2.2 Characterisation of the optical translocation setup

Characterisation of a home-made optical setup follows a sequence of steps starting with designing, assembling, and aligning of the setup. Aligning and fine-tuning the setup requires time depending on level of experience the experimenter possesses. To confirm that the setup is properly aligned, a three step-by-step approach may be implemented starting with the observation of symmetric airy rings formed when the laser is expanded and collapsed controlled by the z-axis of the imaging system and observed on the field of view visualised through the sample imaging system described in section 2.3 and demonstrated on figure 2. Secondly is the formation of cavitation bubbles as the laser interacts with fluid medium as shown on Fig 3. The size and duration of the cavitation bubble formed during laser-cell interaction carries a lot of information. Basically, it can be concluded that the larger the cavitation bubble, the higher the power of the laser. Thirdly is the trapping of silica microspheres which may be properly demonstrated with a video. For the purpose of our experiments, 2 micron silica microspheres (Bang laboratories) were used. When the setup is properly aligned, it is always necessary to switch on the laser at least 30 min to an hour to stabilise before any experiments, and also confirm that the setup is still aligned. The diameter of the laser at the focus using the 60x microscope objective with a numerical aperture (NA) of 0.8 and 0.3 mm working distance was calculated to be 1.22 μm .

$$d = \frac{1.22 \times \lambda}{\text{NA}} \quad (1)$$

Where, d = diameter of the spot, λ = wavelength of the laser, and NA = numerical aperture of the microscope objective [7].

Optimising the power coincide with the laser-cell interaction time. One of this parameter was kept a constant and the other one a variable. In our study, the initial power of 11 μW for photoporation was very high and caused cell damage and death. In order to have a minimum and maximum power value, 11 μW was halved to 5.5 μW as the initial minimum value which was tested at 7 ms laser-cell interaction time and was still high and further split in to 3 μW as minimum and 5 μW as maximum power value. This finding meant that the optimum power lied between the two values. In our study, the 7 ms shutter opening time was kept as a constant while varying the power to determine the optimum power. As soon as the optimum power was determined, the pulse energy, peak power, and fluence could be calculated.

2.3 Optimised photo-translocation parameters

Using the Ti: Sapph RGA femtosecond pulsed laser with a low repetition rate of 1 kHz for photo-poration which was never done before as most studies used higher repetition rate of 80 MHz, these were the optimum parameters using the 800 nm wavelength and 113 fs pulse duration. The optimum power was 4.5 μW to porate adherent CHO cultured over 24 hours. These cells were porated at 7 ms laser-cell interaction time. The diameter of 1.22 μm at the focus results in a calculated effective focal spot area of $1.2 \times 10^{-8} \text{ cm}^2$, therefore the pulse energy at the sample focus was 4.5 nJ, with peak power of ~40 kW, and a fluence of 0.4 J/cm².

2.4 Cell culture

Chinese Hamster Ovary (CHO) cells were cultured regularly using a T-75 vented top culture flask (The Scientific Group, 430641U) in Dulbecco's Modified Eagle's Medium (DMEM) (Sigma-Aldrich, D5796,) supplemented with 10% Fetal Bovine Serum (FBS) (Biochrom, S0615)) and 1% Penicillin-Streptomycin (Sigma-Aldrich, P4333), thus forming complete media. The cells were grown in 37°C, 5% carbon dioxide and 85% humidity incubator until they were 70-80% confluent. When the desired level of confluence was reached, the cells were then trypsinised with trypsin ethylenediaminetetraacetic acid (EDTA) (Sigma-Aldrich, T4049) to the next passage while recording the new passage number on the flask.

2.5 Sample preparation

To prepare for photoporation experiments, 2×10^4 CHO cells were seeded in non-pyrogenic gamma sterilised 35mm glass bottom culture dishes with a usable area of 23 mm and a glass thickness of 0.17 mm (World Precision Instruments, FD35PDL-100) to a total volume of 3 ml complete media and incubated for 24 hours. Following incubation, the cell monolayer was washed with 1 ml of Hank's Balanced Salt Solution (HBSS) (Gibco, 14170088), aspirated, then covered the monolayer with 40 μ l of membrane impermeable 0.4% Trypan blue (Sigma-Aldrich, T8154) with a dilution factor of 3:50. The working area was covered with a 22 mm sterile type-1 coverslip.

2.6 Photo-translocation of trypan blue dye

Following sample preparation, the glass-bottom petri dish was placed on the xyz stage. Each individual cell was treated with one dose of laser at optimum power of 4.5 μ W and laser-cell interaction time of 7 ms. A closed shutter period of 4 seconds was used to move from one treated cell to another. Each cell was allocated 30 seconds post photo-poration to monitor any changes on cell morphology, and a snap shot was taken before photoporation and 30 seconds after for all treated cells. Possible immediate cellular changes such as cell expansion and cytoplasmic blebbing were observed as the laser interacted with each cell. Each culture dish was used for a maximum of 20 minutes before it started desiccating which could possibly give false negative results.

3. RESULTS

During our experiments, it was noticed that the morphology of cells cultured for 24 hours and 48 hours differed. The cells cultured after 48 hours were much bigger and nicely stretched compared to the round and smaller cells after 24 hours of culture incubation as shown on Fig 2 and 3 respectively. From our experimental finding, the stretched cells could be photoporated with a lower power output (3.7 μ W) while keeping the laser-cell interaction time constant at 7 ms. By physical observation, these cells also took-up trypan blue much faster and in larger quantities as illustrated on Fig 2. On the contrary, the optimum power to photoporate the round cells shown on Fig 3 was higher (4.5 μ W) at a constant laser-cell interaction time of 7 ms. Even though these cells were treated with higher power, they took-up trypan blue slower and in fewer quantities compared to the stretched cells after 30 seconds. The influx of trypan blue was concentrated in the nucleus of the cells in both cell populations.

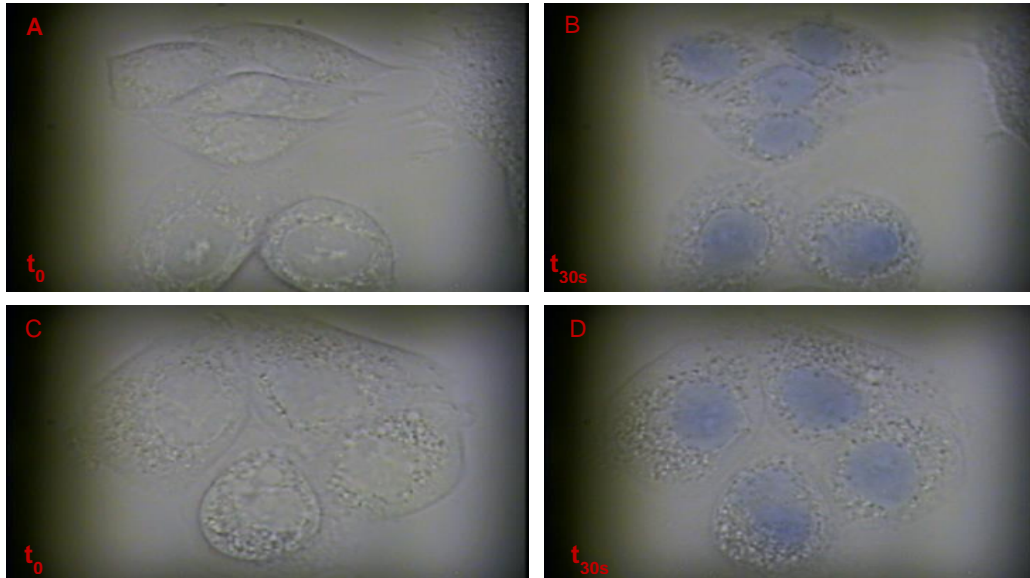

Figure 2: Images demonstrating successful intake of membrane impermeable trypan blue by CHO cells. The cells were cultured for a 48 hour pre phototranslocation. Images A and C show stretched cells before laser interaction and images B and D show cells 30 seconds post phototranslocation using average power of $3.7 \mu\text{W}$ and 7 ms laser-cell interaction time.

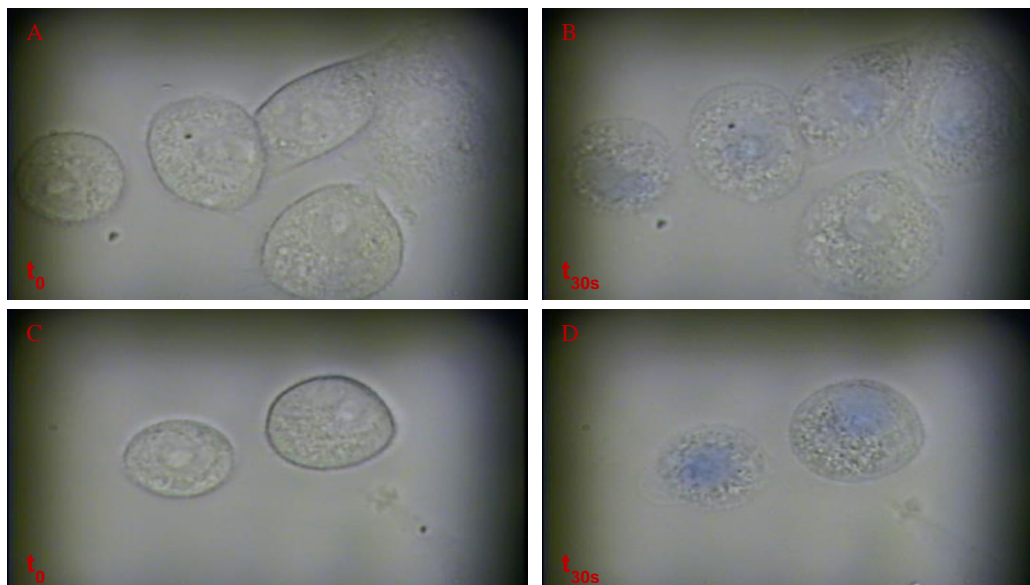

Figure 3: Images demonstrating CHO cells cultured over 24 hours and photoporated with laser at a power output of $4.5 \mu\text{W}$ and laser-cell interaction time of 7 ms. Images A and C show cells before laser treatment and images B and D shows cells 30 seconds later following phototranslocation of membrane impermeable trypan blue dye.

4. DISCUSSION

From the design, assembly, and characterisation of a home-made setup it was evident that several factors play major role to achieve a fully functional and optimised setup. In order to avoid unnecessary misalignments, the design of the setup should be kept as compact and as low as possible and should not include a lot of optics especially when using a low laser power outputs to avoid major loss of power from absorption by multiple optics. Following construction of the optical setup it was noticed that, aligning the rig is a sequential process of events and the core function of the setup. Of note, during the characterisation of the setup, some parameters should be kept constant while varying other parameters to achieve optimum parameters. However, even when the characterisation has been successfully achieved, it is necessary to always confirm alignment of the setup before use and the laser must be switched on to stabilise for at least 30 minutes. For the phototranslocation experiments it is necessary to culture a correct amount of cells for experiments, not too confluent yet not very little. Finally, the optimised parameters must provide reproducible results.

5. CONCLUSION

In our study, it was evident that adherent stretched cells and round cells behave differently when treated with the same power under similar conditions. The successful use of very low power (microwatts) to phototranslocate foreign substances into cells using low repetition rate (1 kHz) femtosecond laser with pulse duration of 113 fs and high peak power may lead to a new field for *in-vivo* targeted drug delivery technique in the field of clinical sciences.

6. REFERENCES

- [1] Dhakal, K., Black, B., & Mohanty, S. (2014). "Introduction of impermeable actin-staining molecules to mammalian cells by optoporation". *Scientific Reports*, 4, 6553. <http://doi.org/10.1038/srep06553>
- [2] Mthunzi, P., Dholakia, K., & Gunn-Moore, F. (2010). "Phototransfection of mammalian cells using femtosecond laser pulses: optimization and applicability to stem cell differentiation". *Journal of Biomedical Optics*, 15(4), 041507. <http://doi.org/10.1117/1.3430733>
- [3] Stevenson, D., Agate, B., Tsampoula, X., Fischer, P., Brown, C. T. A., Sibbett, W., ... Dholakia, K. (2006). "Femtosecond optical transfection of cells : viability and efficiency", *14(16)*, 342–350.
- [4] Waleed, M., Hwang, S. U., Kim, J. D., Shabbir, I., Shin, S. M., & Lee, Y. G. (2013). "Single-cell optoporation and transfection using femtosecond laser and optical tweezers". *Biomed Opt Express*, 4(9), 1533–1547. <http://doi.org/10.1364/BOE.4.001533>
- [5] Kim, T. K., & Eberwine, J. H. (2010). "Mammalian cell transfection: The present and the future". *Analytical and Bioanalytical Chemistry*, 397(8), 3173–3178. <http://doi.org/10.1007/s00216-010-3821-6>
- [6] Stevenson, D. J., Gunn-moore, F. J., Campbell, P., & Dholakia, K. (2010). "Single cell optical transfection".
- [7] Schneckenburger, H., Hendinger, A., Sailer, R., Strauss, W. S. L., & Schmitt, M. (2002). "Laser-assisted optoporation of single cells". *Journal of Biomedical Optics*, 7(3), 410–6. <http://doi.org/10.1117/1.1485758>