

## Reconfigurable Materials Handling System incorporating Part Tracking, Routing and Scheduling

Priyen Naidu<sup>1</sup>

[naidup1@ukzn.ac.za](mailto:naidup1@ukzn.ac.za)

Glen Bright<sup>1</sup>

[brightg@ukzn.ac.za](mailto:brightg@ukzn.ac.za)

Nkgatho S. Tlale

[NTlale@csir.co.za](mailto:NTlale@csir.co.za)

### Abstract

Reconfigurable manufacturing systems refers to the the ability to vary the manufacturing process such that customized products can be manufactured on a large scale. Customization should not impair the production rate of any of the part assemblies. In this regard the tracking of the parts within the manufacturing cycle is important for ascertaining the location of parts within the cycle as well as the history of the completed parts.

This paper outlines the development of a reconfigurable manufacturing materials handling system that uses Radio Frequency (RF) node based tracking system. It details information on a RF tag that is attached to a product. The product is tracked through the manufacturing cycle so that customized operations can be carried out using a mass customization manufacturing process. This paper further discusses the part routing and scheduling system used in the manufacturing cell.

### 1. Introduction

Part tracking is the ability to monitor the location of a part through a manufacturing system. It is more difficult to keep track of part in a reconfigurable system. Reconfigurable manufacturing systems can be used for batch manufacturing implementing a cell manufacturing layout. In these cases a particular manufacturing operation, such as tapping for example, may be done as a batch process after which all products in the batch are placed in storage until they are ready for the next process. In these cases it is not possible to keep track of a particular part unless it is uniquely identifiable by the manufacturing control system.

A practical way of achieving this is through the use of an Indoor Position System (IPS), usually based on sensory technologies such as Radio Frequency Identification (RFID), to track the position of each part in an indoor environment. This technology also provides the history of a part's manufacturing cycle and this information can be used to refine the process and as a

diagnostic tool if flawed parts are produced. The process should also be optimized by improving part routing and scheduling systems. This can be done using databases and wireless communication between the part, various machining centres and host computers. This will reduce the number of bottlenecks in a manufacturing environment, as the manufacture of custom products is only feasible if the speed of the mass-manufacturing process is not impaired.

### 2. Current Tracking Technologies

Tracking technologies are those that allow the control computer to know where a part is in a manufacturing environment at any time. Some of the commonly available technologies that are suitable for tracking networks include Infrared (IR), Radio frequency (RF), Direct Current (DC) Electromagnetic and Global Positioning System (GPS). [Diegel, 2004]

Due to their ubiquitous deployment infrared (IR) transceivers are inexpensive, compact, and low power. IR propagation is fast but effective bandwidth is limited by interference from ambient light and from other IR devices in the environment. IR signals reflect off most interior surfaces but diffracts around few. Typical range is up to 5 meters [Diegel, 2004].

Radio frequency (RF) signals offer several benefits over IR. RF signals diffract around and pass through common building materials. RF signals compare favorably to IR in propagation speed, bandwidth, and cost. Since the RF spectrum is heavily regulated, typical systems operate at 900MHz or 2.45GHz and comply with Part 15 Federal Communications Commission (FCC) regulations so as not to require licensing. Transmission range of 10m-30m indoors is common. RFID is a commonly available system which uses either low-cost passive Radio tags, or higher cost active tags, that an RF receiver can then read. An RFID system comprises of a reader, its associated antenna and the transponders, (tags/RFID cards), that carry the data. The reader transmits a low-power radio signal, through its antenna, that the tag receives via its own antenna to power an integrated circuit. Using the energy it gets from the signal when it enters the radio field, the tag will briefly converse with the reader for verification and the exchange of data. Once

that data is received by the reader it can be sent to a controlling computer for processing and management [Diegel, 2004].

DC electromagnetic fields have been used in many high-precision positioning systems. While the signal propagation speed is high range is limited to 1m-3m. These signals are very sensitive to environmental interference from a variety of sources including the earth's magnetic field, and even metal in the area. Thus, systems based on these signals need precise calibration in a controlled environment.

Ultrasound signals are becoming more common in positioning systems where the relatively slow propagation speed of sound, (343m/s), allows for precise measurement at low clock rates, making ultrasound based-systems relatively simple and inexpensive. The signal frequency is limited by human hearing on the low end and by short range on the high end. A keen human ear can hear 20KHz sounds. Typical systems use a 40KHz signal. Conveniently, standard sound cards have a 48KHz sampling rate --- sufficient for ~ 1cm resolution distance measurements. Environmental factors have substantial but not prohibitive effects on ultrasound propagation, particularly speed. Humidity can slow ultrasound by up to 0.3%. Finally, ultrasound reflects off most indoor surfaces. Empirical studies show that 40KHz ultrasound signals reverberate at detectable levels for at most about 20ms.

GPS was developed by the US military. It has been in consumer use in the last five years with the availability of affordable navigation tools. These devices usually include GPS receivers to locate the user and a map database to give context such as streets and surroundings. Sometimes the device can also compute the best route from a source to a destination, or store these planned trips for later retrieval. GPS features positioning accuracy of roughly 10m. For it to function, the receiver must be in line of sight of four satellites above, or be able to receive a supplementary correction signals from a ground station. Due to these limitations, GPS is not a useful tool for indoor or underground navigation. Also, GPS cannot distinguish adjacent levels or floors of buildings [Diegel., 2004].

With regard to wireless RF protocols, Bluetooth, ANT, Zigbee were investigated. A comparative table is shown in Table 1. All of these operate within the 2.4 GHz band however it can be seen from the comparison that ANT has the smallest power requirement and uses the least amount of system resources. It was decided that the Bluetooth protocol be used because of the commercial availability of the Bluetooth components.

	ANT	Bluetooth	ZigBee
Frequency	2.4 GHz	2.4 GHz	2.4 GHz
Bit Method	GFSK	GFSK	QPSK
RF data rate	1 Mbps	1 Mbps	250 kbps
Frequency channels	79	79	16
System resources	2k-4k	250k	32k
Coin cell battery life	4 years	1 month	5 months
Encryption available	Yes	Yes	Yes
Supported Network	Star, Peer-to-	Peer-to-Peer	Star Peer-to-

types	Peer		Peer
Minimum RF node configuration	Transmit or Transceiver	Transciever	Transceiver

Table 1: Comparison between RF protocols [http://linuxdevices.com/news/NS5278997632.html]

## 2.1 Bluetooth Communication

Bluetooth is a communication standard that allows electronic equipment to automatically establish connections wirelessly and without any direct action from the user. Bluetooth is intended to be a standard that works at two basic levels [Franklin, 2000]. It provides agreement between devices at the physical level. Bluetooth is a radio-frequency standard. It also provides agreement at the next level up, where products have to agree on when bits are sent, how many will be sent at a time and how the parties in a conversation can be sure that the message received is the same as the message sent.

Bluetooth communicates on a frequency of 2.45 GHz, which is set aside by an international agreement for the use of industrial, scientific and medical devices.

There is always a danger in any system using many wireless devices that one device interferes with another that it is not supposed to. One of the ways that Bluetooth devices avoid interfering with other devices in the same frequency range is by sending out only very weak signals of about 1mW. The low power limits the range of a Bluetooth device to about 10m, (for class 2 devices), thus reducing the chances for interference between devices.

Bluetooth also uses a technique called spread-spectrum frequency hopping to avoid devices interfering with each other by decreasing the likelihood of devices being on the same frequency. In this technique, a device will use 79 individuals, randomly chosen frequencies within a designated range, changing from one to another on regular basis. In the case of Bluetooth, the transmitters change frequencies 1600 times every second [Diegel, 2005].

## 3. Proposed Tracking System

The proposed tracking system consists of a two phases. In the first phase a passive radio frequency (RF) tag is read by a RF reader. In the second phase the information obtained from the reader is wirelessly communicated to the host computer using Bluetooth adapters. In this way the host computer can establish the position of the part. Both the RF devices and tag readers are found on each machine in Figure 3. The tag reader interfaces with the RF device using a microcontroller. The microcontroller is equipped with a serial connection into which a Bluetooth adapter is connected. The adapter is also connected to the host computer. This allows for two way communication such that any machine can transmit the position of the part to the host and the host can transmit instructions to the machines of how to proceed. The KC111 Bluetooth Serial Adapter was chosen for this application.

### 3.1 Construction of an RF tag

An rPIC12F675 transmitter module was used to be the electronic transmission device. The rPIC12F675

transmitter module contains:

- 2 push-button switches connected to GP3 and GP4
- 2 potentiometers connected to GP0 and GP1
- RF enable (RFenin) connected to GP5
- Data ASK (DATAask) connected to GP2
- Optional 8-pin socket (U2) for In-Circuit Emulation (ICE) or inserting an 8-pin DIP package version of the PIC12F675

The push-button switch GP3 was used as the main power switch. The push-button switch GP4 was removed and the Low Frequency Communication Circuit was linked to pin GP4. This Low Frequency Communication Circuit (LFCC) acted as an electronic switch with a very short range (typically, 20cm). If no low frequency signal was received by the rfPIC12F675 module, the module sent only the product ID every 1 second. If the rfPIC12F675 module received a low frequency command within the LFCC range, the pin GP4 was pulled-up and the module started to send all the information contained in the tag (Product ID, Operations to be performed, etc.) [Diegel, 2004].

Those potentiometers connected to GP0 and GP1 were not used. A power reduction resistor was added on, and the length of the antenna was shortened to decrease the transmission range to approximate 2.5 meters. This was an important step as, if the range of the transmitter were too large, it would communicate with too many receiver nodes, making it more difficult to pinpoint a precise location. The data transmitted from the rf12F675 module used its own code transmission format, in which there were four distinct parts to every code word transmission as follows: Preamble, Header, Data and Guard Time. The preamble started the transmission and consisted of repeating low and high phases each of length  $T_e$  representing the elemental time period. The header consisted of a low phase which had a length of  $10 * T_e$ . Next came the data bits. The data bits were Pulse Width Modulated (PWM). A logic one was equivalent to a high of length  $T_e$ , followed by a low of length  $2 * T_e$ . A logic zero was equivalent to a high of length  $2 * T_e$ , followed by a low of length  $T_e$ . The final part of the code word transmission was the guard time which was the spacing before another code word was transmitted [Diegel, 2004].

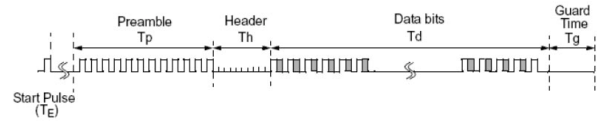

Figure 2: Transmitter Pulse Train [Diegel, 2004]

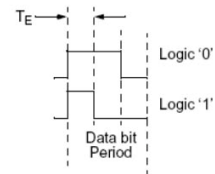

Figure 3: Encoding Method [Diegel O., 2004]

The encoding method used for the transmission was a 1/3 2/3 PWM format with  $T_e$  (basic pulse element).

The device used the following data format: the preamble was 10101010 (8-bits sequence), followed by a 0000 (4-bits) header. The data section contained the product ID, Description, and four different operations to be carried out. Each of these operations was represented by either a blue or red light depending on the configuration of each robot, as discussed in the next section. The last section was the Guard Time which consisted of 8 bits 0 [Diegel, 2004].

#### 4. Part Routing and Scheduling System for Customization

The manufacturing cell, shown in Figure 4, consists of a conveyor, an automatic storage and retrieval system (AS/RS), a reconfigurable machine system (RMS), an automated visual inspection system (AVIS), an automated guided vehicle (AGV) and 2 pick-and-place robots. The peripheral machines such as the lathe, saw, engraver, tap and polishing centre are hypothetical machining centres. It is in this cell that the part must be tracked continuously to facilitate product customization.

Although the manufacturing cell could be adapted to manufacture many products, the routing and scheduling system proposed below is designed specifically for manufacturing dumbbells, both standard and customized.

The dumbbells consist of a bar, clamp and plates. It was assumed that steel shafts and plates are available for secondary machining. In the interests of flexibility, the cell was able to manufacture customized products. The variations of dumbbell parts that are possible with the cell are shown in Figure 5.

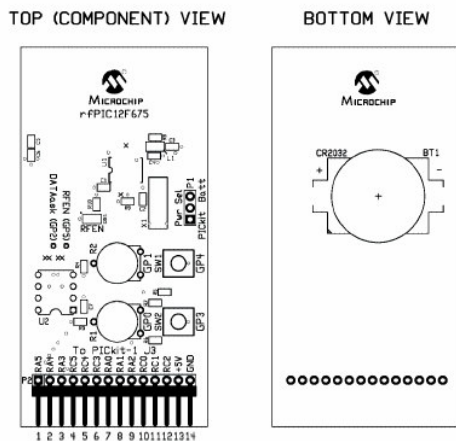

Figure 1: rfPIC12F675 Transmitter Module (Microchip Technology inc)

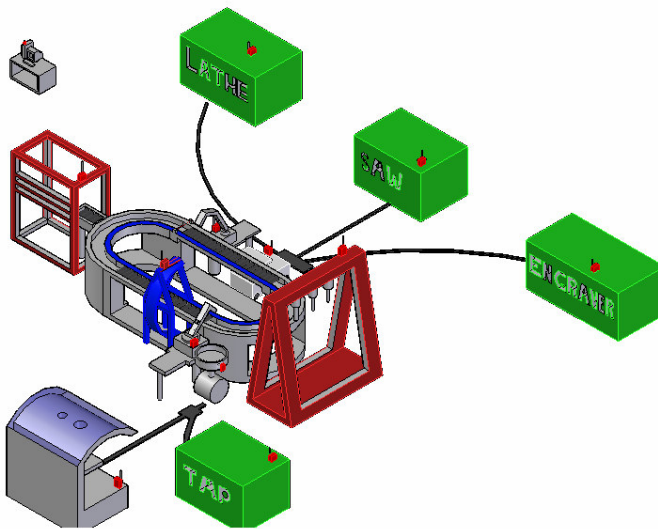

Figure 4: Agile Manufacturing Cell

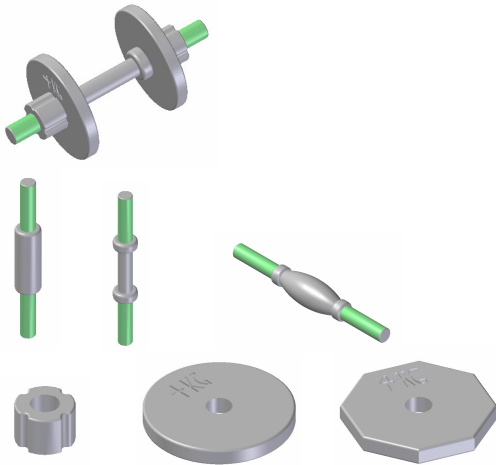

Figure 5: Bars, clamps and plates are parts that can be manufactured by the cell

The whole manufacturing process was controlled by a host computer using wireless communication. The host assigned manufacturing processes to the various parts (bar, clamp, plate) from a database, shown in Table 2, that was continually updated as the parts moved through the cell.

The database and RF readers that were used were adapted from a home security system that indicated when and where a door had been opened with an RF tag. This fitted the purpose as the RF sensors would read the tag when it was within a 10 cm proximity. This information was then conveyed to the host computer's database thus providing the location of a specific part at any given time.

	Sawing	Turning	Drilling	Milling	Grinding	Engraving	Tapping	Threading
Bar	X	X			X			X
Plate			X		X	X		
Clamp	X		X	X	X		X	

	Knurling	Polishing
Bar	X	X
Plate		X
Clamp		X

Table 2: Database of manufacturing processes required to manufacture a single dumbbell.



Figure 6: RF tag reader system adapted from a home security system as an Indoor Positioning System (IPS) ([www.aperfectpicklocksmiths.ca](http://www.aperfectpicklocksmiths.ca))

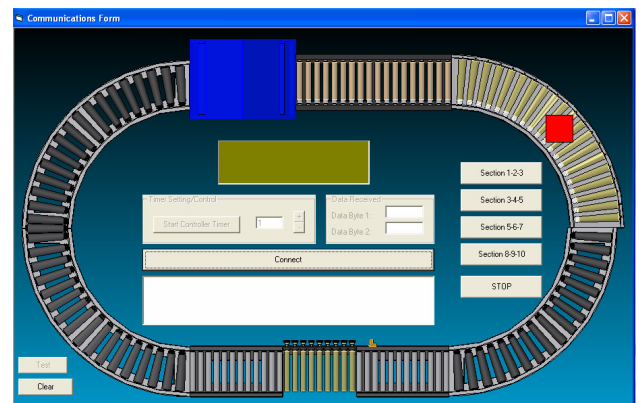

Figure 7: The graphical user interface for the manufacturing control program

Alarm	Door Status	Date	Time	Terminal	Event	Name	Tag
		2006-03-28	10:33:05	(05) Lathe	Allowed In	T1	208040389082
		2006-03-24	13:00:35	(05) Lathe	Allowed In	T1	208040389082
		2006-03-23	16:13:52	(00)	Power Up		
		2006-03-23	16:26:17	(05) Lathe	Allowed In	T1	208040389082
		2006-03-23	06:21:26	(05) Lathe	Allowed In	T1	208040389082
		2006-03-22	12:56:32	(00)	Power Up		
		2006-03-21	20:35:36	(05) Lathe	Allowed In	T1	208040389082
		2006-03-21	14:46:59	(05) Lathe	Allowed In	T1	208040389082
		2006-03-21	14:46:56	(05) Lathe	Allowed In	T1	208040389082
		2006-03-21	14:46:50	(05) Lathe	Allowed In	T1	208040389082
		2006-03-21	14:46:47	(05) Lathe	Allowed In	T1	208040389082

Figure 8: The form for the database showing the part's activity

The components of the RF reader system are shown in Figure 6.

The database, in Figure 8, also shows information regarding the time and date of the event. This information is stored so that the part's history can be studied in the event of a flawed part being produced. The database can also be accessed by the cell's control program. Based on the inputs that the control program received from the database, further instructions could then be delivered to the cell regarding how to proceed for that particular part. The graphical user interface (GUI) for the

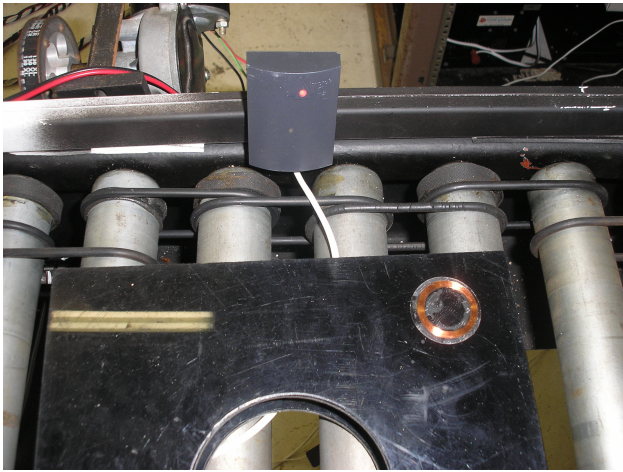

Figure 9: Tagged pallet being identified by the RF reader control program is shown Figure 7.

The parts travelled through the manufacturing cell on a plastic pallet. A passive RF tag was placed on every pallet. Each tag had a unique 12 digit identification code. Tag readers and RF devices were placed at various locations throughout the cell to track the part and pallet by communicating via Bluetooth with a host computer. A RF reader and RF tagged pallet are shown in Figure 9.

Figure 11 illustrates the plan view of the agile manufacturing system. The components were placed on pallets and stored in the AS/RS prior to manufacturing. The AS/RS released an unknown part with its pallet onto the conveyor. The pallet travelled clockwise around the conveyor until it crossed a laser sensor which caused that section of the conveyor to stop moving such that the pallet was directly in front of the first pick-and-place robot. A reader and RF device, located on the robot, read the tag and linked with the database. In this way the part was identified for the first time. The host computer then started a process queue for the part. The host then told the robot to pick up the part and place it on the AGV. The AGV was then told by the host to go to a machining centre such as the lathe. All the machining centres had RF tag readers so that the parts cannot be confused. The lathe with the RF reader is shown below in Figure 10.

The AGV docked with the lathe, which proceeded to machine the part according to its computer numerically controlled (CNC) programming. The peripheral machines were also controlled by the host for the CNC operations. The AGV then returned to the conveyor in the mean time to transport other parts back



Figure 10: Lathe with RF reader attached.

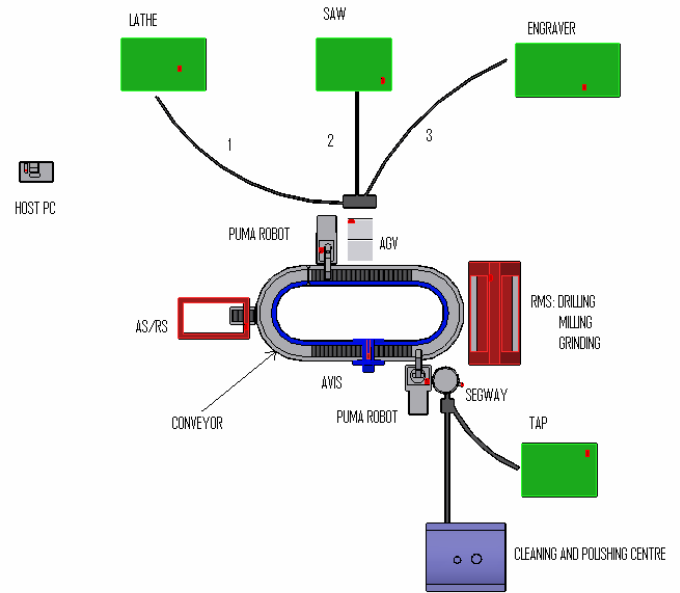

Figure 11: Plan view of Agile Manufacturing Cell

and forth. When the lathe had completed the operation on the part it communicated this with the host computer and host then sent the AGV to fetch the part from the lathe. The database was also updated to show that the lathe operations had in fact been performed on that particular part. In similar fashion the part was sent to the saw and the engraver. When those processes were performed and the part was brought to the conveyor, the host then update the database and told the robot to place the part on the conveyor again.

The part travelled to the next sensor pair which stopped the conveyor such that the part is directly in front of the Reconfigurable Machine System (RMS). The tag was read by the RMS reader and this was communicated to the host which gave instructions to a transfer system to transfer the part into the RMS. The host told the computer to perform the relevant processes on the part. When the processes were performed the RMS informed the host which in turn instructed the transfer system to transfer the part back onto the conveyor. The database was once again updated.

The part was placed back on the conveyor where it continued to travel until it crossed the next sensor pair where it stopped again opposite another pick-and-place robot. The tag was read and the part was placed on the SEGWAY, an autonomous materials handling system, which was then told by the host to travel to either the tap or the polishing center depending on the part. The tag was read again and the processes were performed using CNC. The host was informed upon completion of the machining processes and the SEGWAY fetched the polished parts and the robot places them back on the conveyor. The database is updated once again.

The part was placed back on the conveyor where it travelled through the AVIS which had a RF reader which checked whether the part was indeed to specification. The database was updated when it was established that the quality of the part was satisfactory. The completed part is finally returned to the AS/RS via the transfer system where the database was updated for the last time.

## 5. Conclusion

The application of the principle for the tracking, routing and scheduling of parts in a Reconfigurable Manufacturing system can be adapted to more complex products and assemblies. A dumbbell set was used as a simple example of a product that could be manufactured in a mass customization environment.

A passive tag has been used as a tracking beacon that is read by an RF reader. The RF reader was placed on all the machines in the manufacturing cell. These devices communicate wirelessly with a host computer that issued further instructions based on the feedback from the RF readers. In this way the tag, which was situated on a pallet, could be tracked throughout the entire process and part information was stored in database for future reference should the quality of the part be sub-standard.

The interference was minimal when communicating the information wirelessly between the RF system and the host computer. Bluetooth's Spread-Spectrum Frequency Hopping feature was useful to avoid possible jamming or interference of signals that could arise from the RF system.

As a means to reduce bottlenecks, an accumulator, (a mobile section of the conveyor), should be introduced to remove and re-introduce parts into the cell that are inhibiting other parts from being processed faster. The reduction of bottlenecks by using these means will be given further attention.

## References

[Goebel P., 2004] P Goebel. *Reconfigurable*

- Manufacturing Systems*. Proceeds of the International Conference on Competitive Manufacturing, COMA'04, pp. 69-79, Stellenbosch, South Africa, 2004
- [Potgieter J., 2002] Johan Potgieter and Glen Bright. *Modular Mechatronic Control System for Internet Manufacturing*. Proceeds of the 18th International on CAD/CAM, Robotics and Factories of the future, pp. 529-536 Porto, 2002
- [Kalpakjian S. Schmid S.R. 2001] *Manufacturing Engineering and Technology*. Prentice-Hall, London, 2001
- [Krar S., Arthur G, 2003], *Exploring Advanced Manufacturing Technologies*. New York, Industrial Press, 2003
- [Diegel O., 2004] Olaf Diegel, Johan Potgieter and Glen Bright. *Mass-Manufacturing: Low cost, Radio frequency, node based indoor tracking networks, CARs&FOF*,2004
- [Diegel O, 2005] Olaf Diegel, Glen Bright, Johan Potgieter., *Bluetooth ubiquitous networks: seamlessly integrating humans and machines*, Assembly Automation, volume 24 number 2. pp. 168-176 , 2005
- [Franklin, C. 2000], *How Bluetooth Works*, available at:  
<http://www.howstuffworks.com>  
<http://www.rfdesign.co.za/default.asp?pageID=65699706>  
[http://www.kcwirefree.com/docs/KC121\\_Datasheet.pdf](http://www.kcwirefree.com/docs/KC121_Datasheet.pdf)  
<http://www.bluetooth.com/>  
<http://linuxdevices.com/news/NS5278997632.html>  
<http://ww1.microchip.com/downloads/en/AppNotes/tb069a.pdf>  
[http://www.aperfectpicklocksmithe.ca/ixp\\_200\\_keyless\\_access\\_control\\_systems.html](http://www.aperfectpicklocksmithe.ca/ixp_200_keyless_access_control_systems.html)