

17/89

ROCK MECHANICS ASPECTS OF STOPING WITHOUT BACK-AREA SUPPORT

R G King, A J Jager, M K C Roberts, P A Turner

Rock Engineering

RESEARCH REPORT NO 17/89
TASK GR2P10/GR8A
JUNE 1989

ROCK MECHANICS ASPECTS OF STOPING
WITHOUT BACK-AREA SUPPORT

R G KING, A J JAGER, M K C ROBERTS
and P A TURNER

Rock Engineering

RESEARCH REPORT NO. 17/89
PROJECT NO. GR2P10 / GR8A
JUNE 1989

COMRO

ROCK MECHANICS ASPECTS OF STOPING WITHOUT BACK-AREA SUPPORT

R G King, A J Jager, M K C Roberts, P A Turner

Rock Engineering

RESEARCH REPORT NO 17/89
TASK GR2P10/GR8A
JUNE 1989

KEYWORDS: DEFORMATION
INSTRUMENTATION
MONITORING
STRATA MOVEMENT
SUPPORT

INTENDED FOR THE USE OF MEMBERS OF THE CHAMBER OF MINES
OF SOUTH AFRICA ONLY

© Chamber of Mines of South Africa 1989

This publication is copyright under the Berne Convention. In terms of the Copyright Act, No. 98 of 1978, no part of this publication may be reproduced or transmitted in any form or by any means, electronic or mechanical, including photocopying, recording or by any information, storage and retrieval system, without permission in writing from the Chamber of Mines of South Africa.

PREFACE

COMRO has, in the past, put considerable effort into developing an understanding of the non-elastic behaviour of the fractured skin of rock which surrounds deep excavations. However, quantitative estimates of the amount of strata movement or deformation which takes place within this fracture zone are not easily obtained and, despite the major effort which has been put into this area, this information is, to a large extent, still lacking. This has serious implications for the design of support systems for the working area in stopes, since it is in this area that falls of ground occur, resulting in many casualties, primarily because of the fractured nature of the hangingwall.

This report discusses observations made of hangingwall and footwall strata movement during the mining of two panels by the 'caving' (i.e. no back-area support) method. Different face support systems were used in the two panels, one with a significantly higher support resistance than the other. The results obtained provide a good insight into the behaviour of the fracture zone and it has been possible to devise a conceptual model of the one which can be used to assess the various non-linear numerical models available to the Industry for simulating the fracture zone. However, in many respects, the results are erratic, indicating the discontinuous nature of the fractured zone and suggesting that, far from behaving as a coherent, if fractured, beam, relatively small areas of the hangingwall may respond independently of the surrounding strata.

This discontinuous response of the hangingwall is being addressed in another field experiment at present and it is intended to carry out similar field trials in other mining districts during 1990. In this way quantitative information which is required for designing stope layouts and support systems for these stopes should be obtained.

N C GAY
DIRECTOR
ROCK ENGINEERING

SUMMARY

This report is intended for use by mine management and rock mechanics personnel who would be interested in using a system of stoping without back area support.

The report describes an experiment carried out at Hartebeestfontein Gold Mine, No. 6 Shaft, 77 N 25 Stope between October 1985 and November 1986, which involved mining two panels without back-area support and with very different support resistances in the face area. The aim was to determine the influence of the support systems on face conditions and to examine fracturing around the stope area.

The panels were extensively instrumented and monitored using extensometers, closure stations, support load monitors, stress determination and fracture mapping. Of particular interest was an instrumented raise developed ahead of the face and subsequently undermined.

From the analysis of the results obtained a tentative conceptual model is proposed which postulates a mechanism for the large measured inelastic convergences. The mechanism involves dilation of mining-induced fractures ahead of the face which results in high horizontal stress in the immediate hangingwall and footwall, and subsequent sliding on bedding planes and some buckling of the strata.

CONTENTS

LIST OF FIGURES	(vi)
1. INTRODUCTION	1
1.1 Background	1
2. SITE	2
2.1 Geology	2
2.2 Mining Geometry and Support	4
2.2.1 Mining Geometry	4
2.2.2 The working area support systems	4
2.3 Instrumentation	7
2.3.1 Closure measurement	7
2.3.2 Raise	7
2.3.3 Extensometers	7
2.4 Mining-induced fracturing	9
3. RESULTS	10
3.1 The Effectiveness of the 'Cave'	10
3.2 Closure Measurements	12
3.2.1 Closure	12
3.2.2 Closure rates in the stope face area	12
3.2.3 Dip closure profiles	12
3.2.4 The time dependent behaviour of the closure	12
3.3 Raise Measurements	17
3.3.1 Horizontal shear movements	17
3.3.2 Vertical movements	23
3.4 Extensometer Measurements	23
3.4.1 Centre gully extensometers	23
3.4.2 Number 10 strike gully extensometer	23
3.4.3 Panel extensometers	24
3.4.4 Raise extensometers	24
3.5 Mining Induced Fracturing	24
3.5.1 Fractures related to previous mining activity	24
3.5.2 Fracture orientation	25

4.	DISCUSSION	25
4.1	Stope Closure	25
4.1.1	Stope closure rate in the working area	25
4.1.2	Time dependence	27
4.2	Movement on Bedding Planes	27
4.2.1	Shearing	27
4.2.2	Extension	29
4.3	Hangingwall Dilation	29
4.4	Mining Induced Fracturing	31
5.	CONCLUSIONS	32
5.1	Conceptual Model	33
6.	RECOMMENDATIONS	35
7.	REFERENCES	35
	APPENDIX I 'CAVING' THEORY	38
	APPENDIX II THE STICK SUPPORT SYSTEM	42
	APPENDIX III GEOLOGY	44
	APPENDIX IV INSTRUMENTATION	45
	APPENDIX V EXTENSOMETER RESULTS	49
	APPENDIX VI CLOSURE RESULTS	76
	APPENDIX VII FRACTURE SURVEY RESULTS	82

LIST OF FIGURES

1.	Location of 77 N 25 stope in relation to surrounding mining	3
2.	Stoping geometry at the end of the mining	5
3.	Support configuration on the two panels	6
4.	Positions of the extensometers and the raise	8
5.	Profile of the 'caved' hangingwall	11
6.	Change in closure rates in panel 9 North	13
7.	Change in closure rates in panel 10 North	14
8.	Dip profile of closure rate	15
9.	Change in closure rate after mining stopped	16
10.	Horizontal strike movement in the raise relative to peg E	18
11.	Horizontal dip movement in the raise relative to peg E	19
12.	Vertical movement in the raise relative to peg E	20
13.	Change of raise position with time relative to face position	21
14.	Dip cross-section of raise showing bedding, pegs and extensometer No. 9	22
15.	Diagram of vertical displacement created by horizontal shearing of non-planar surfaces	28
16.	Hangingwall dilation not measured by the extensometer	30
17.	Conceptual model of fracturing and deformation around a deep gold mine stope	34
18.	Effect of shearing on bed separation and areas of contact	36
I.1	a. Fracture development around a normal stope	
	b. Remote from the dip gully	
	c. Fracture development around a 'caving' stope	39
I.2	a. Inflection of fractures in the footwall	
	b. Inflection of fractures in the hangingwall	40
II.1	Comparison of support resistance for the different support systems	43

IV.1	Position of the lines of closure measuring pegs	46
IV.2	Dip cross-section of raise showing bedding, pegs and extensometer No. 9	48
V.1	Extensometer number 2, days	51
V.2	Extensometer number 2, metres from face	51
V.3	Extensometer number 3, days	52
V.4	Extensometer number 3, metres from face	52
V.5	Extensometer number 4, days	53
V.6	Extensometer number 4, metres from face	54
V.7	Extensometer number 1, days	58
V.8	Extensometer number 1, metres from face	58
V.9	Extensometer number 1a, days	59
V.10	Extensometer number 1a, metres from face	59
V.11	Extensometer number 11, days	60
V.12	Extensometer number 11, metres from face	60
V.13	Extensometer number 12, days	61
V.14	Extensometer number 12, metres from face	61
V.15	Extensometer number 13, days	62
V.16	Extensometer number 13, metres from face	63
V.17	Extensometer number 14, days	64
V.18	Extensometer number 14, metres from face	64
V.19	Extensometer number 5, days	67
V.20	Extensometer number 5, metres from face	67
V.21	Extensometer number 6, days	68
V.22	Extensometer number 6, metres from face	68
V.23	Extensometer number 7, days	69
V.24	Extensometer number 7, metres from face	69
V.25	Extensometer number 8, days	70
V.26	Extensometer number 8, metres from face	70
V.27	Extensometer number 9, days	73
V.28	Extensometer number 9, metres from face	74

V.29	Extensometer number 10, days	75
VI.1	Hangingwall dilation not measured by the extensometer	77
VI.2	Change in closure rates in panel 9 North	78
VI.3	Change in closure rates in panel 10 North	79
VI.4	Change in closure rate after mining stopped	81

1. INTRODUCTION

An understanding of the interaction between the support system and the surrounding rock mass in deep gold mine stopes is of great importance in the design of support systems. With this end in mind a task was set up to investigate this interaction with particular emphasis on a mining system which used no back-area support. In this report the effect on the fractured rock mass of two support systems with markedly different support resistances is examined in terms of closure rate, hangingwall conditions and strata movement for two panels in which no back-area support was used. An extensive instrumentation programme was used to measure the deformations around the stope, and a raise was developed ahead of the stope and then undermined to measure any deformation which occurred as the face approached and passed under it.

1.1 Background

For many years a system of stoping in which no back area support is installed and only the working area is supported has been carried out successfully on one mine in the Klerksdorp area. The area behind the supported face either collapses spontaneously, or, more usually, is blasted down, resulting in a 'caved' back-area.

Between 1977 and 1979 the Chamber of Mines successfully mined 40 936 m² in seven panels on two different longwalls in the Carletonville area, using only barrier props and three rows of standard hydraulic props, with no back area support (Basson *et al.*, 1984). However, in this case the collapse was not induced. Few falls of ground occurred in the back-area and the stope was closed 30 - 40 m behind the stope face. From a strata control point of view the experiment was successful, with improved hangingwall conditions and face advance. Significantly, seismic events which caused rockbursts in adjacent panels caused no damage in the panels with no back-area support.

The benefit of mining without back-area support is that a major saving in material and manpower costs can be effected, as no permanent support needs to be installed, other than along gullies.

In addition it has been reported that benefits in terms of improved hangingwall, face and gully conditions have been observed when this mining method has been used (Appendix I).

The purpose of the experiment reported here, was twofold: to determine the effects of the mining method and support system on rock mass deformation, and to quantify any improvements in face conditions and to explain them in terms of the rock mechanics aspects.

2. SITE

The site chosen for the experiment was the number 9 North and 10 North panels of the 77 North 25 raise connection, close to the shaft pillar, at the number six shaft of the Hartebeestfontein Gold Mine in the Klerksdorp Gold Field (Figure 1). These were mined on breast by the Mining Branch of the Chamber of Mines Research Organization between January 1986 and December 1986. This is the only gold mine which uses the 'caving' method to any great extent and which is familiar with the stope support requirements for this type of mining.

Face support for the conventional 'caving' practiced by the mine comprises five rows of mine poles of which the last row is blasted out when the face advances (See Appendix II). At the time of the experiment the mine was beginning to substitute hydraulic props for mine poles.

2.1 Geology

A detailed geological description is contained in Appendix III.

The hangingwall consisted of a 1 m to 1,5 m siliceous quartzite bed overlain by well bedded quartz wacke. The beds in the quartz wacke varied between 0,1 m and 1,3 m thick with a mean of 0,8 m. The partings were generally impersistent in their horizontal extent.

Few joints were recorded in the hangingwall, and no prominent faults were intersected during the mining of the two panels.

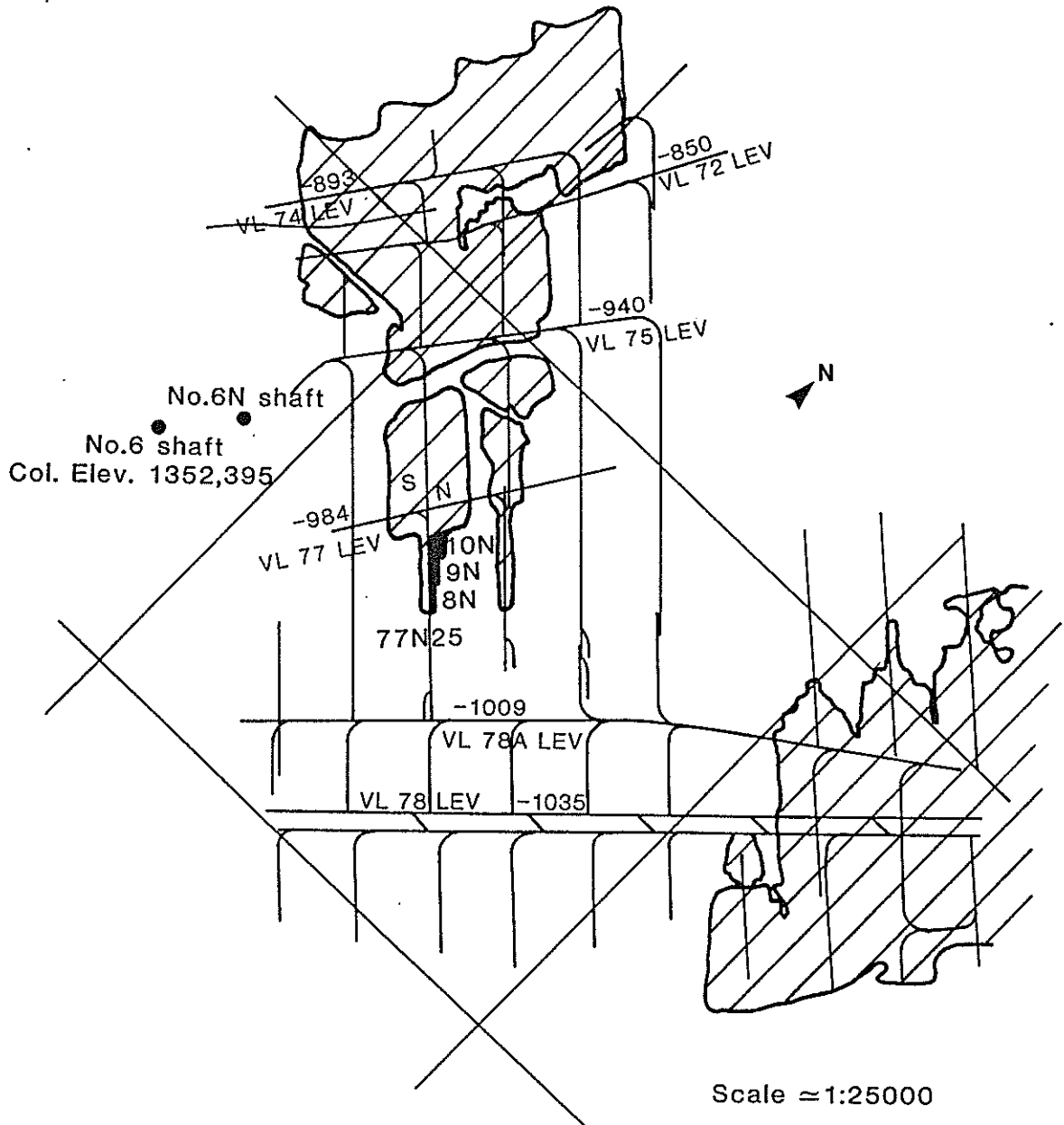

Figure 1 LOCATION OF 77 N 25 STOPE IN RELATION TO SURROUNDING MINING

2.2 Mining Geometry and Support

2.2.1 Mining Geometry

The geometry of the 77 North 25 stope and the surrounding mined and unmined areas before mining the number 9 N and 10 N panels is shown in Figure 1. Figure 2 shows the geometry at the completion of mining of these panels. A MINSIM analysis indicated that the ERR at these faces would vary between 20 MJ/m² at the start of mining, and 45MJ/m² when the configuration in Figure 2 was reached.

2.2.2 The working area support systems

The support used on both panels 9 N and 10 N comprised several dip rows of hydraulic props in the stope face area with no back-area support; on the 9 N panel barrier props were incorporated into the back line of props. At the beginning of the stoping experiment the number 9 N panel was advanced a short distance so that it would be in line with the 10 N panel. The support used up to this stage, on both panels, was a combination of mat packs and wedge props. At the point when the strike span of the stope was 56 m, dip slots 1,5 m deep were cut 7 m behind the face of both panels in the hangingwall and footwall. Hangingwall extensometers were then installed in the middle of the panels between the face and the dip slots, roughly 2 m from the face. The two panels were then advanced 5 m using wedge props as support. With further face advance, the wedge props were systematically replaced with hydraulic support.

The 10 N panel had a dip length of 36 m; three rows of 200 kN hydraulic props were installed 1,6 m apart on strike and 1,2 m apart on dip. Additional hydraulic props were installed on dip, midway between each pair of hydraulic props in the back row, giving an effective dip spacing of 0,6 m. The support resistance in this panel was calculated to be 95 kN/m², assuming a distance after the blast of 3 m between the face and the first line of hydraulic props (Figure 3). This contrasts with an overall support resistance of 28 kN/m².

The 9 N panel was also 36 m long. In this panel four rows of 400 kN yield hydraulic props were installed 1,2 m apart on strike and 1,2 m apart on dip. In addition, 1 600 kN yield barrier props were installed between the last row of hydraulic props. The barrier props were spaced 2,4 m on dip. Assuming a distance of 3 m between the face and the first line of hydraulic props, the support resistance of this support system is 277 kN/m², approximately three times that of panel 10N (Figure 3).

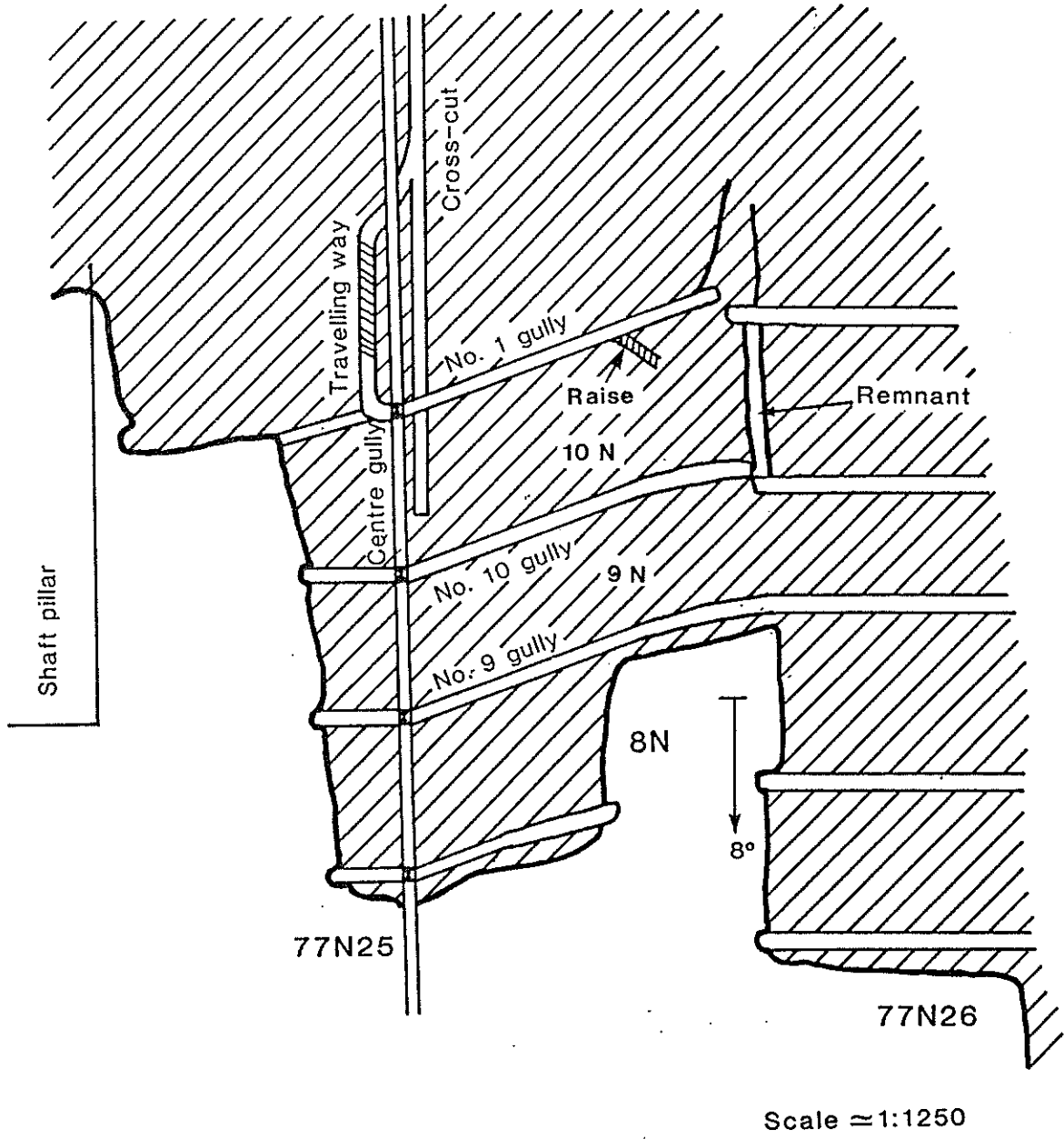

Figure 2 STOPPING GEOMETRY AT THE END OF THE MINING

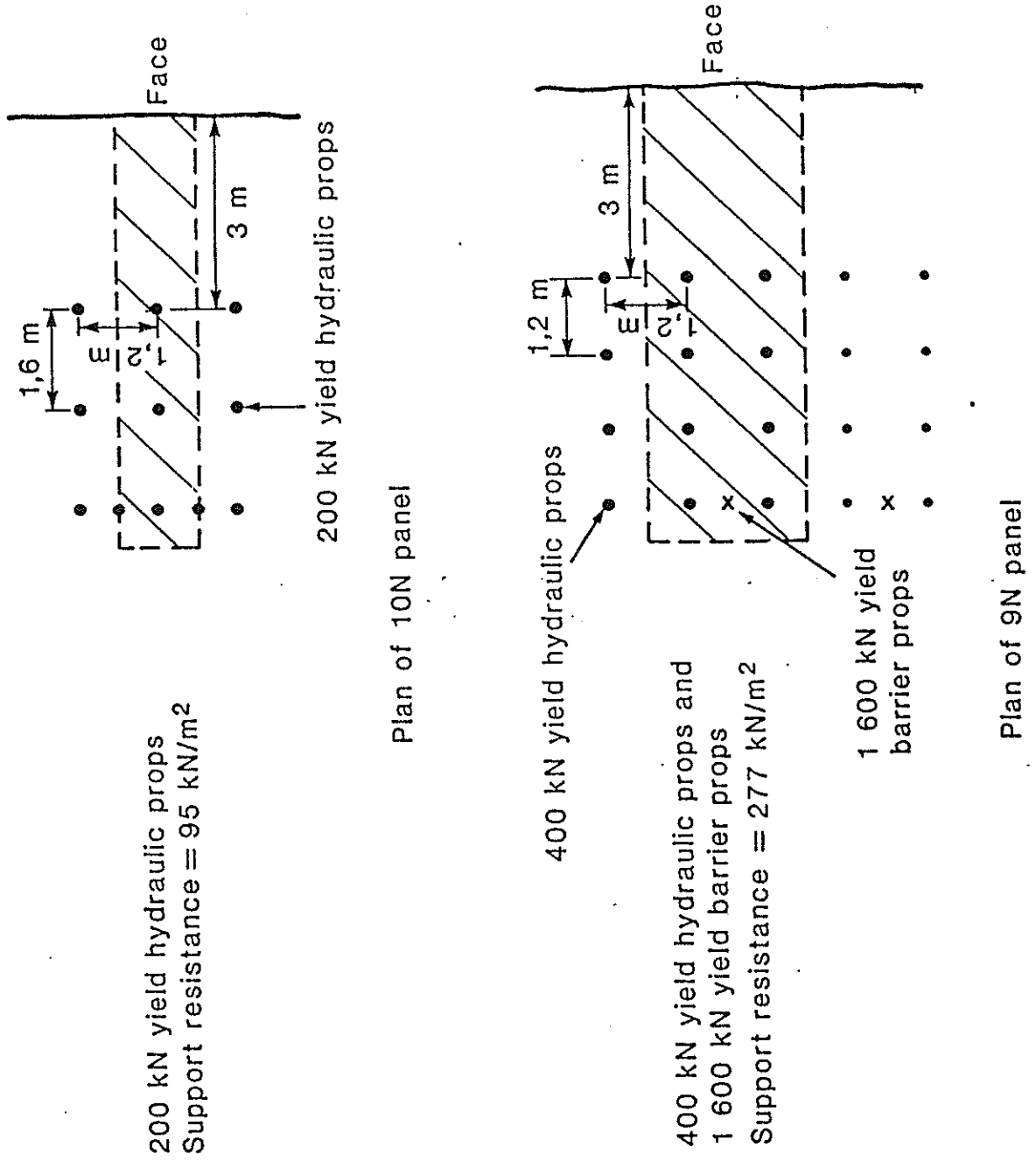

Figure 3 SUPPORT CONFIGURATION ON THE TWO PANELS

The gully support consisted of a double row of 1,2 m by 1,2 m EPS packs installed 1,2 m skin to skin on strike in a chequerboard pattern.

2.3 Instrumentation

Appendix IV contains detailed descriptions of the instrumentation used.

Three instrumentation systems were used to record deformations around the stope:

- (i) closure measuring stations and continuous closure meters;
- (ii) a survey of the raise ahead of the stope face, and
- (iii) extensometers

2.3.1 Closure measurement

Three lines of closure stations were monitored in each face. The pegs were installed approximately 2 m from the face and measurements were taken until they were inaccessible behind the last row of props, a distance of between 5 m and 8 m.

The continuous closure meters were installed from time to time behind the blast barricade to give more accurate readings especially during blasting.

2.3.2 Raise

From the number one strike gully of the down dip extremity of the previous mining, a short cross raise was developed into the hangingwall above 10 North panel before it was mined (Figure 4). The movement of the hangingwall of the raise was surveyed regularly and two extensometers were installed at the top, extending down to the reef horizon.

2.3.3 Extensometers

The main form of instrumentation at the site was wire extensometers.

Fifteen extensometer stations were installed (Figure 4), thirteen in the hangingwall and two in the footwall.

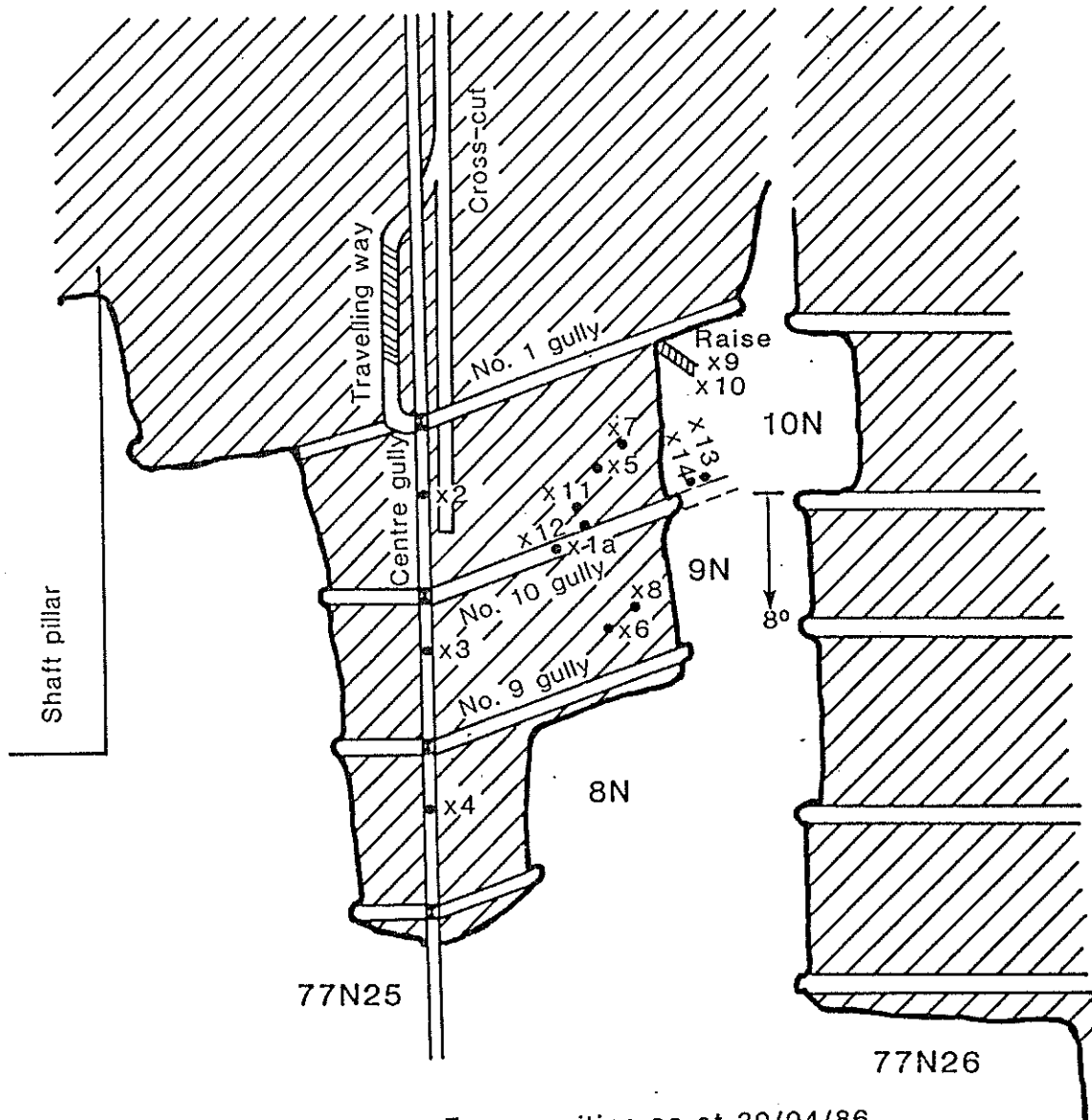

Face position as at 30/04/86

•x Extensometer positions

Scale \approx 1:1250

Figure 4 POSITIONS OF THE EXTENSOMETERS AND THE RAISE

The extensometers were installed in four different areas of the stope:

the centre gully	- No.'s 2, 3 & 4
number 10N gully	- No.'s 1, 1a, 11, 12, 13 & 14
the panels	- No.'s 5, 6, 7 & 8
the raise	- No.'s 9 & 10

Numbers 9 and 10 were in boreholes drilled down from the top of the raise to the reef horizon. Number 9 covered the region from 8 m to 14 m below the raise footwall and number 10 covered the first 10 m. They were installed when the boreholes were 12 m and 15 m, respectively, in front of the face. Extensometer 10 was cut-off very early so additional anchors were installed in number 9 to cover the first 7 m of strata below the raise.

2.4 Mining-induced fracturing

A study of the stress induced fracturing was carried out as 'caving' of the back-areas has been purported to result in several modifications of the mining-induced fracture geometry (Appendix I). It was hoped that these modifications would occur and that an understanding of the underlying causes of the changes could be achieved.

The predominant face parallel fractures in the hangingwall were logged in both panels. Several profiles of fracture spacing and inclination were measured along traverses in the area between the centre gully and the hangingwall slot used to initiate the caving as well as in the areas between the stope face and the 'cave'.

Analysis of the fracture orientations and separations along the traverses was carried out to compare fractures induced before and after the 'cave' had been initiated.

3. RESULTS

3.1 The Effectiveness of the 'Cave'

Because of the potential danger from falling hangingwall rock, the 'caved' area could only be viewed from the back edge of the face support or from the protection of the gullyside pack lines to determine its geometry. Thus the height to which the unsupported area had fallen out and the nature of the bounding detachment surfaces of the 'cave', could only be assessed occasionally and the dimensions estimated. The height to which the first 'cave' occurred was, usually, only approximately 40 cm, the height to the first stratigraphic parting plane. This was followed by further 'caving' which occurred 2 m to 3 m further back. The maximum height of cave observed was approximately 3 m.

Once mining had advanced beyond the initial stoping area in which timber prop support had been used, the 'cave' in both the 10 N and 9 N panels usually extended as far as the back prop line. The forward extension of the 'cave' normally took place simultaneously with or within a few minutes or hours of the remote removal of the temporary Camlok props which were used as an additional safety device during the removal of the hydraulic props. Sometimes, however, the hangingwall would hang-up often for 10 m or more on strike.

In the 9 N panel the caved area was closest to the props in the mid-panel region during most of the experiment. At the top and bottom of the panel the cave front lagged and extended back obliquely towards the pack supported region adjacent to the gullies. In the 10 N panel this oblique, backward extension of the edge of the cave occurred only at the bottom of the panel. At the top of the panel, the hangingwall caved up to the back prop line, almost to the edge of the gully packs as the hangingwall was very blocky due to the presence of siding parallel fractures from the earlier mining (Figure 5).

On a number of occasions, the collapse of the hangingwall on the 10 N panel over-ran the last row of props along a dip distance of up to five metres. The collapse never extended beyond the next row of props. A contributory factor was the tendency of the rock to fracture directly over the heads of props which had no headboards installed. These fractures were either conical, with the apex of the cone based on the prop head; multiple fractures within a cone over the prop or; a spalling off towards a face-parallel fracture immediately adjacent to the prop line.

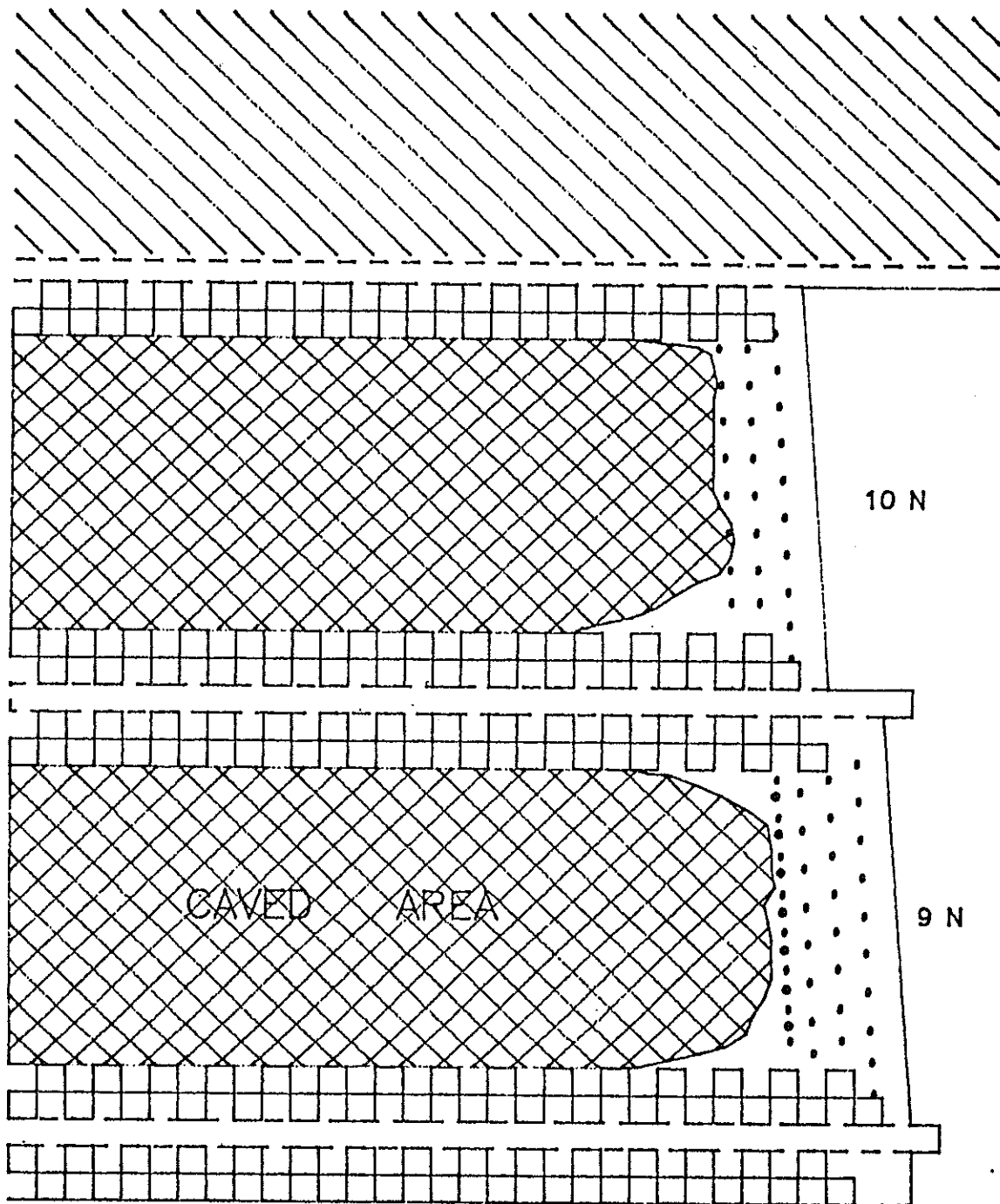

Figure 5 PROFILE OF THE 'CAVED' HANGINGWALL

3.2 Closure Measurements

Detailed results are given in Appendix VI

3.2.1 Closure

For a mining step of 5 m face advance MINSIM predicted 50 mm of convergence in the stope face area, whereas the measured closure was up to five times as much.

3.2.2 Closure rates in the stope face area

The daily closure rate in the working area decreased with increasing strike stope spans and decreasing remnant width from about 16 mm / day when the remnant width was 36 m, to 6 mm / day when the width had decreased to 21 m, as illustrated in Figure 6 for panel 9 N.

Figure 7 is a similar plot for panel 10 N where the closure rate decreased from 16 mm / day to 8 mm / day for the same change in remnant width.

The closure rates of 6 mm / day and 8 mm / day remained almost constant during the extraction of the final 20 m of the remnant.

3.2.3 Dip closure profiles

Figure 8 shows the closure profile along a line on dip down both panels compared to the average support resistance in those panels.

3.2.4 The time dependent behaviour of the closure

Also of interest is the behaviour of the stope after the mining activity ceased. The closure continued at the same rate as during mining for three to five weeks after the last blast had been taken and then tailed off as shown in Figure 9.

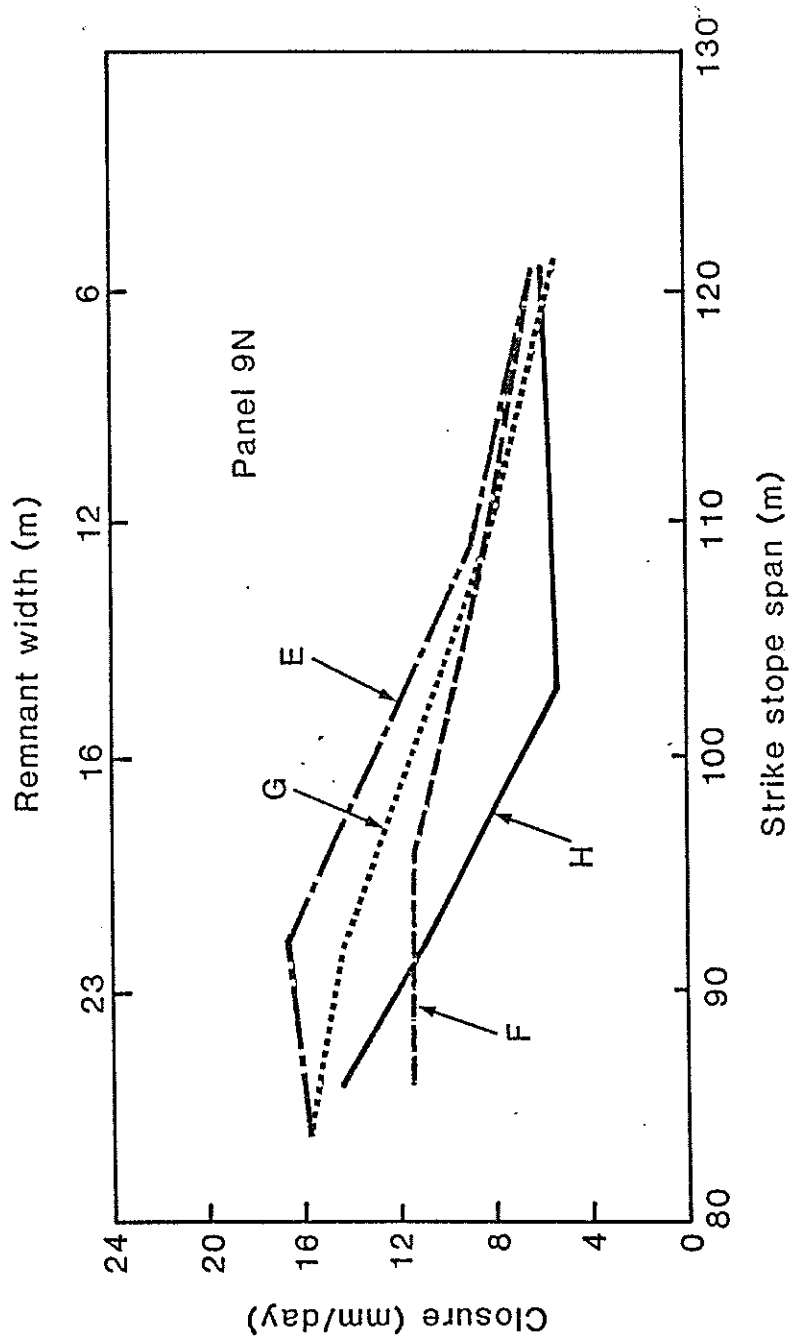

E - H = LINES OF CONVERGENCE PEGS

Figure 6 CHANGE IN CLOSURE RATES IN PANEL 9 NORTH

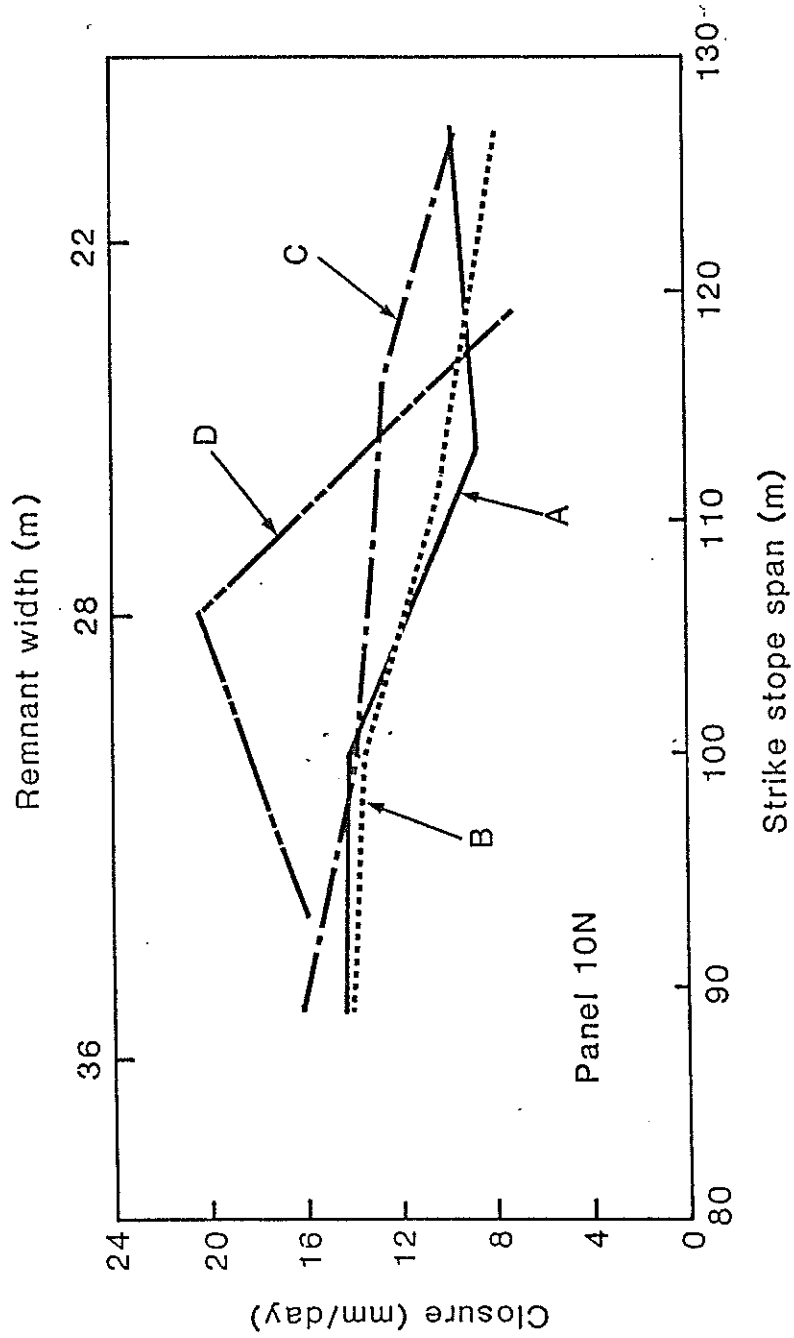

A - - D = LINES OF CONVERGENCE PEGS

Figure 7 CHANGE IN CLOSURE RATES IN PANEL 10 NORTH

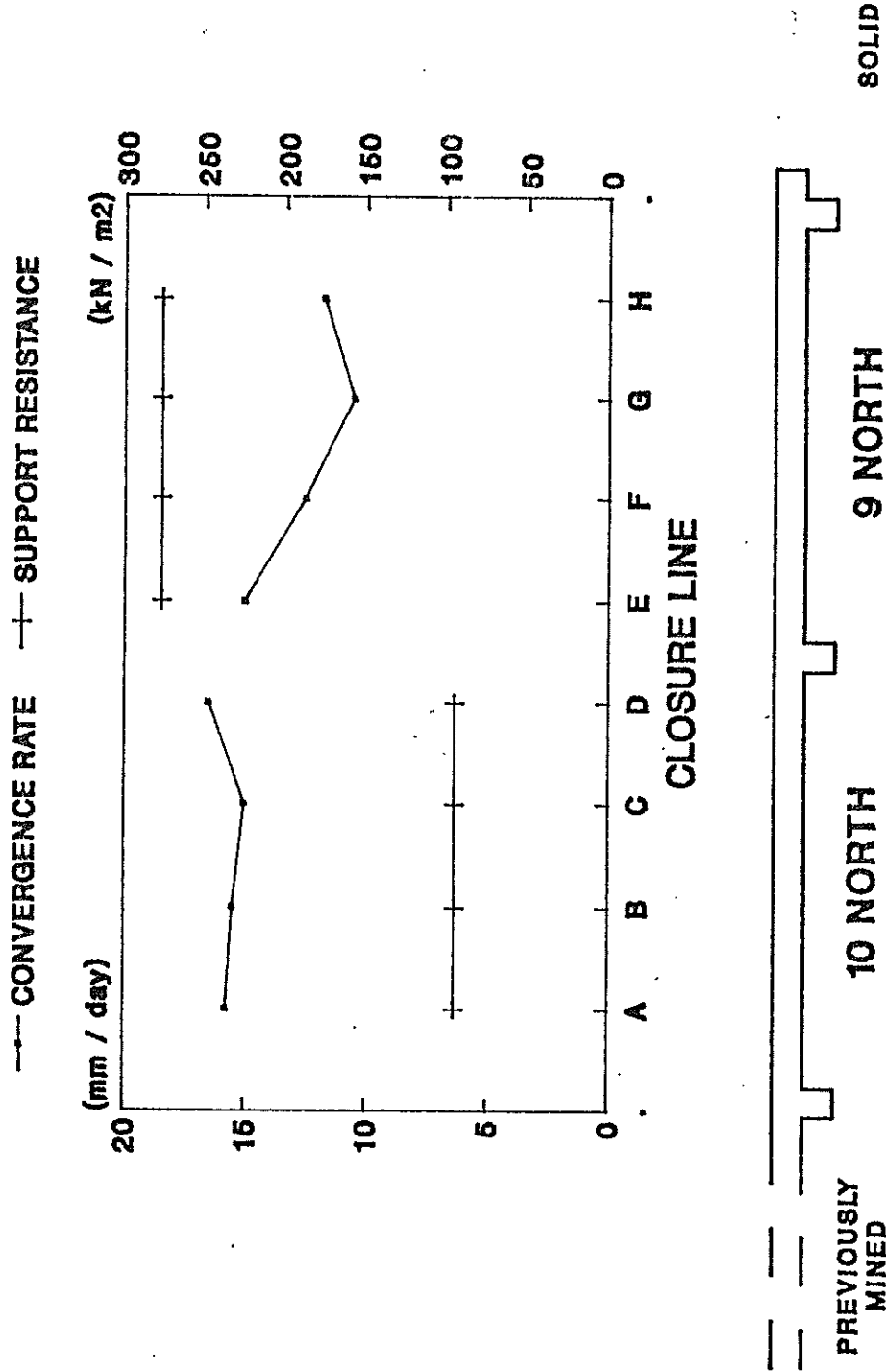

Figure 8 DIP PROFILE OF CLOSURE RATE

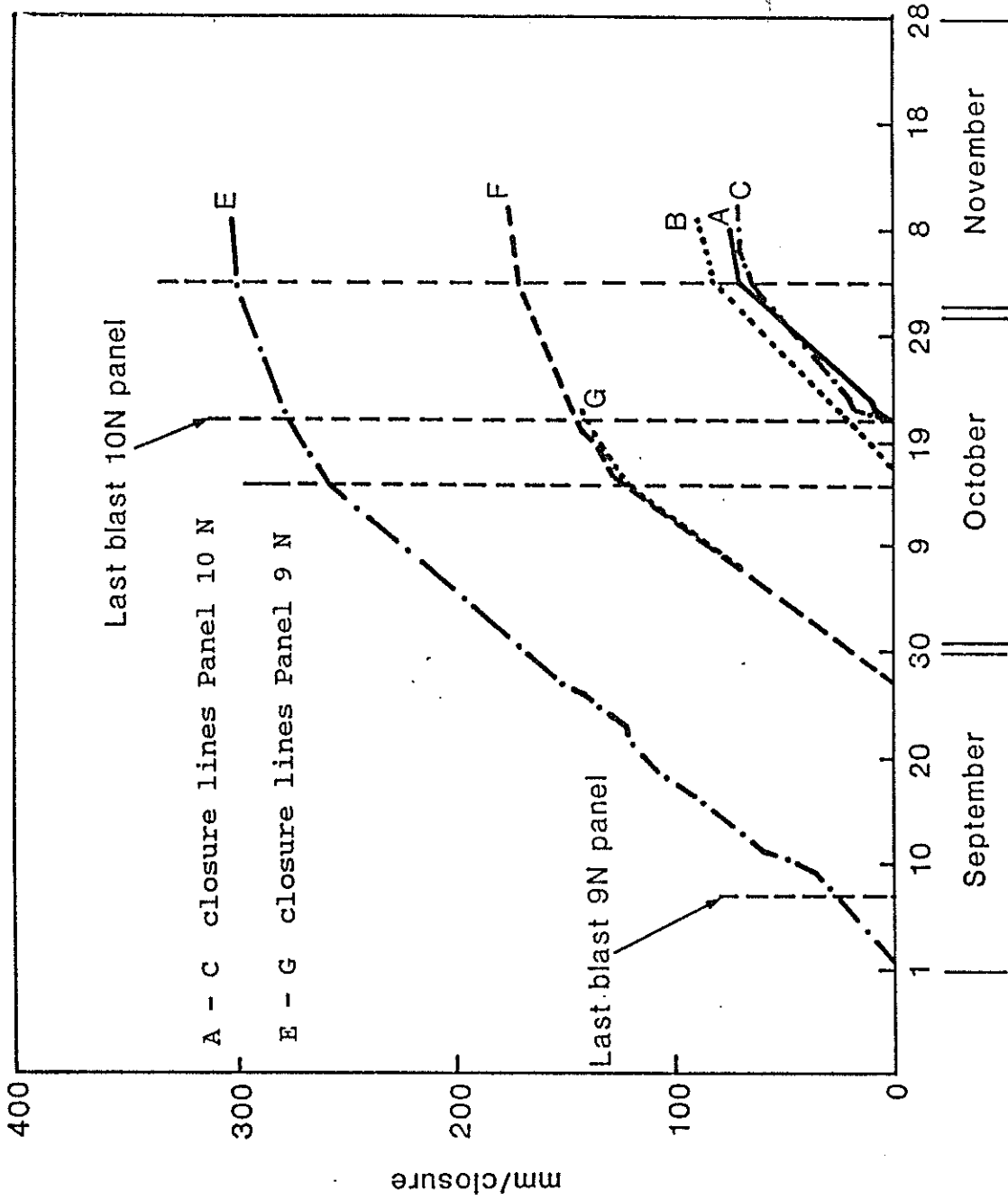

Figure 9 CHANGE IN CLOSURE RATE AFTER MINING STOPPED

3.3 Raise Measurements

For clarity the movements of the pegs in the raise are considered separately as horizontal movements in the strike and dip directions and vertical movements, Figures 10, 11 and 12 respectively, all related to peg E near the top of the raise.

One problem with the interpretation of the data is that the raise was developed 45 ° off true dip and was thus not parallel to the stope face. This means that at any particular time the position of the individual pegs differs in relation to the face position (Figure 13).

Shear occurred on many of the beds particularly on those which had previously been recorded as having fair or good parting potential when the raise was geologically mapped (Figure 14).

In general the movements in the raise appeared to migrate upwards as the face advanced towards and undermined the raise.

3.3.1 Horizontal shear movements

The initial strike shear movement was towards the solid as the face approached the raise position then back towards the mined out area as the face undercut the raise and moved away. The dip shear reacted similarly moving down dip as the face approached and back again as it undercut.

The dip shear movements were larger than the strike, especially as the face approached the raise, when most of the movement occurred. Between 5,5 m and 8 m several beds sheared in a down dip direction with a maximum shear of 120 mm, with another major shear between 3,3 m and 4,3 m showing a similar amount of shear but in the opposite direction. In the strike direction the corresponding maximum shears were only around 50 mm.

As the raise was undermined most of the shearing was recovered, with little additional shearing except near the bottom of the raise, below 5 m.

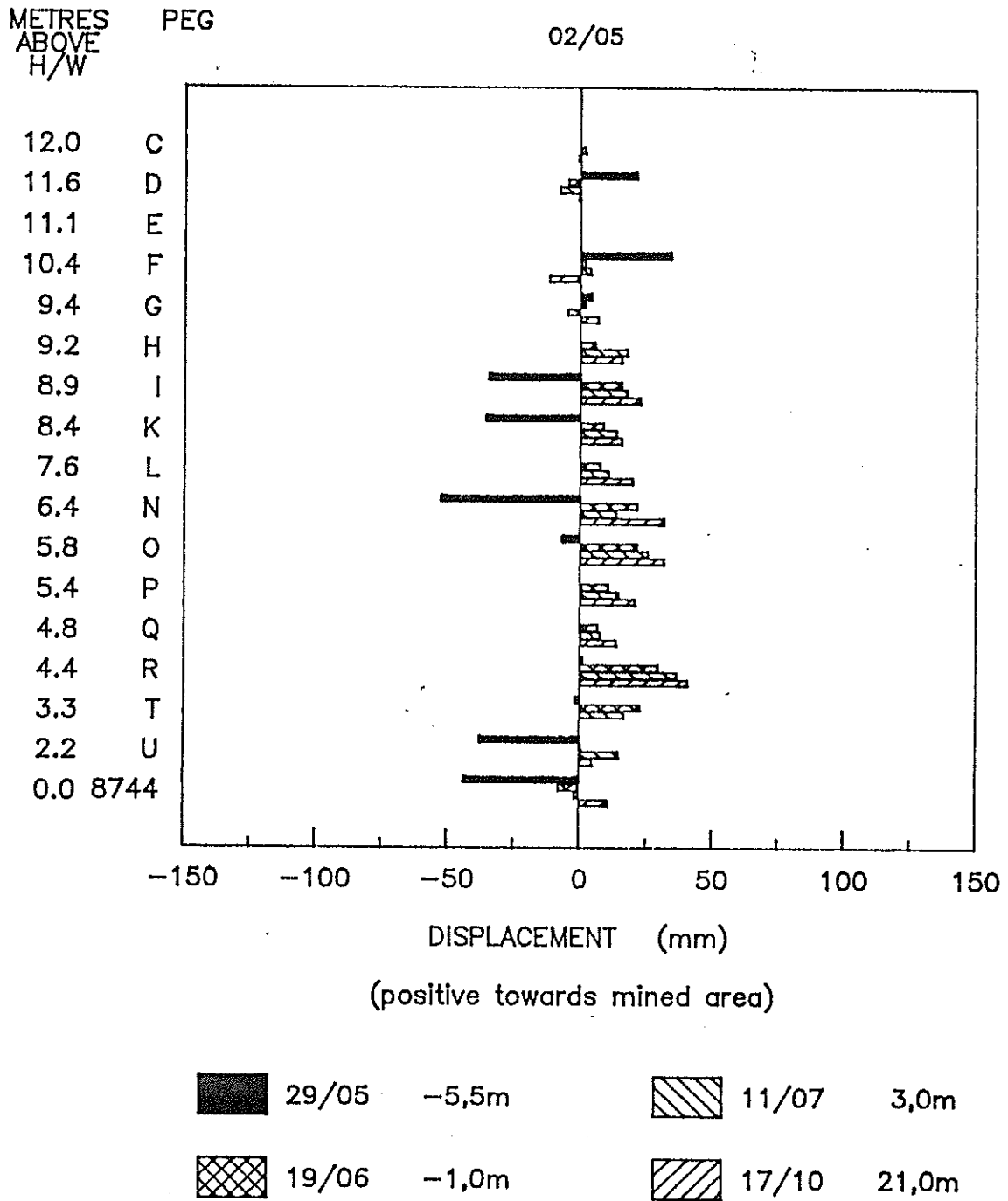

Figure 10 HORIZONTAL STRIKE MOVEMENT IN THE RAISE RELATIVE TO PEG E

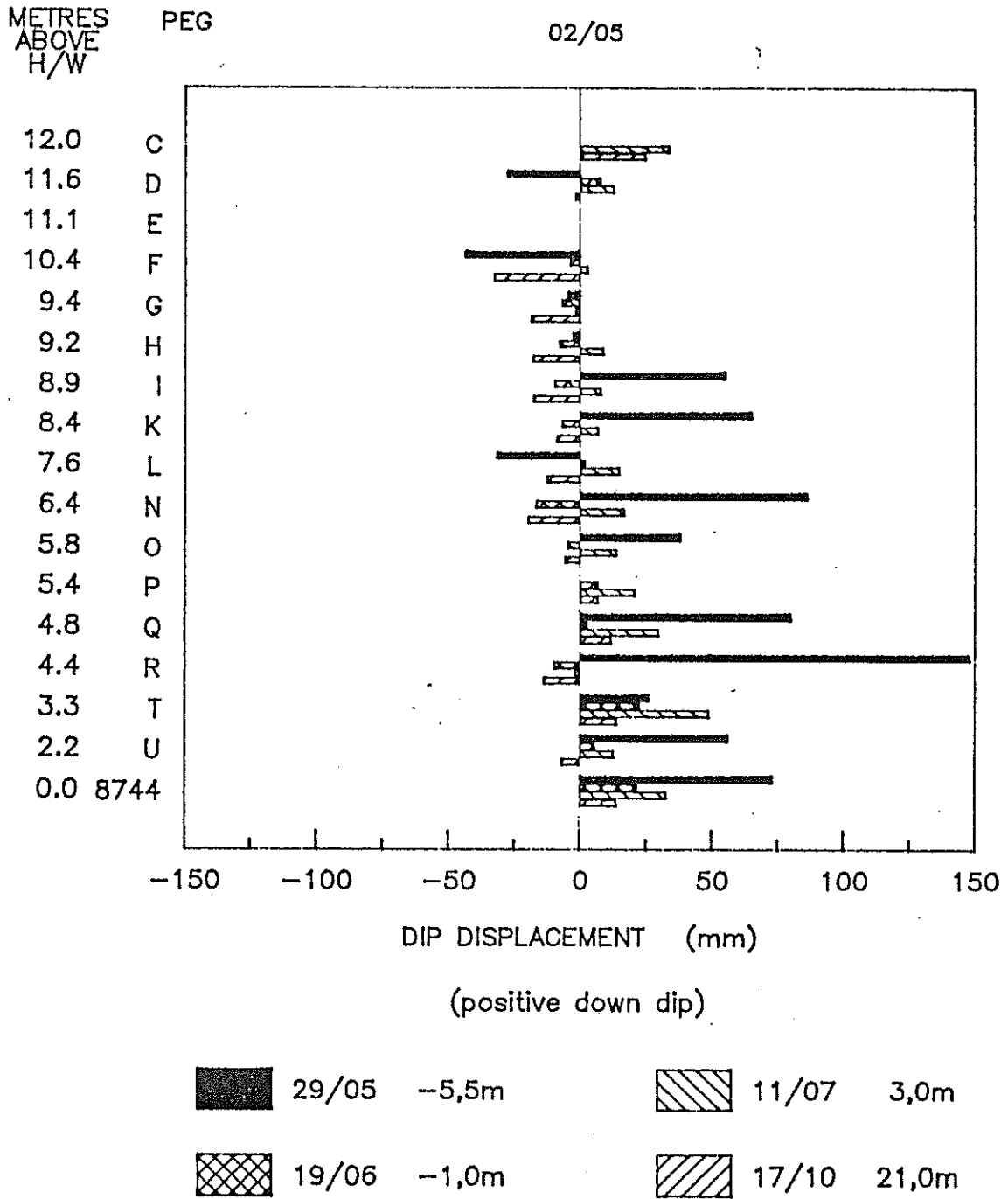

Figure 11 HORIZONTAL DIP MOVEMENT IN THE RAISE RELATIVE TO PEG E

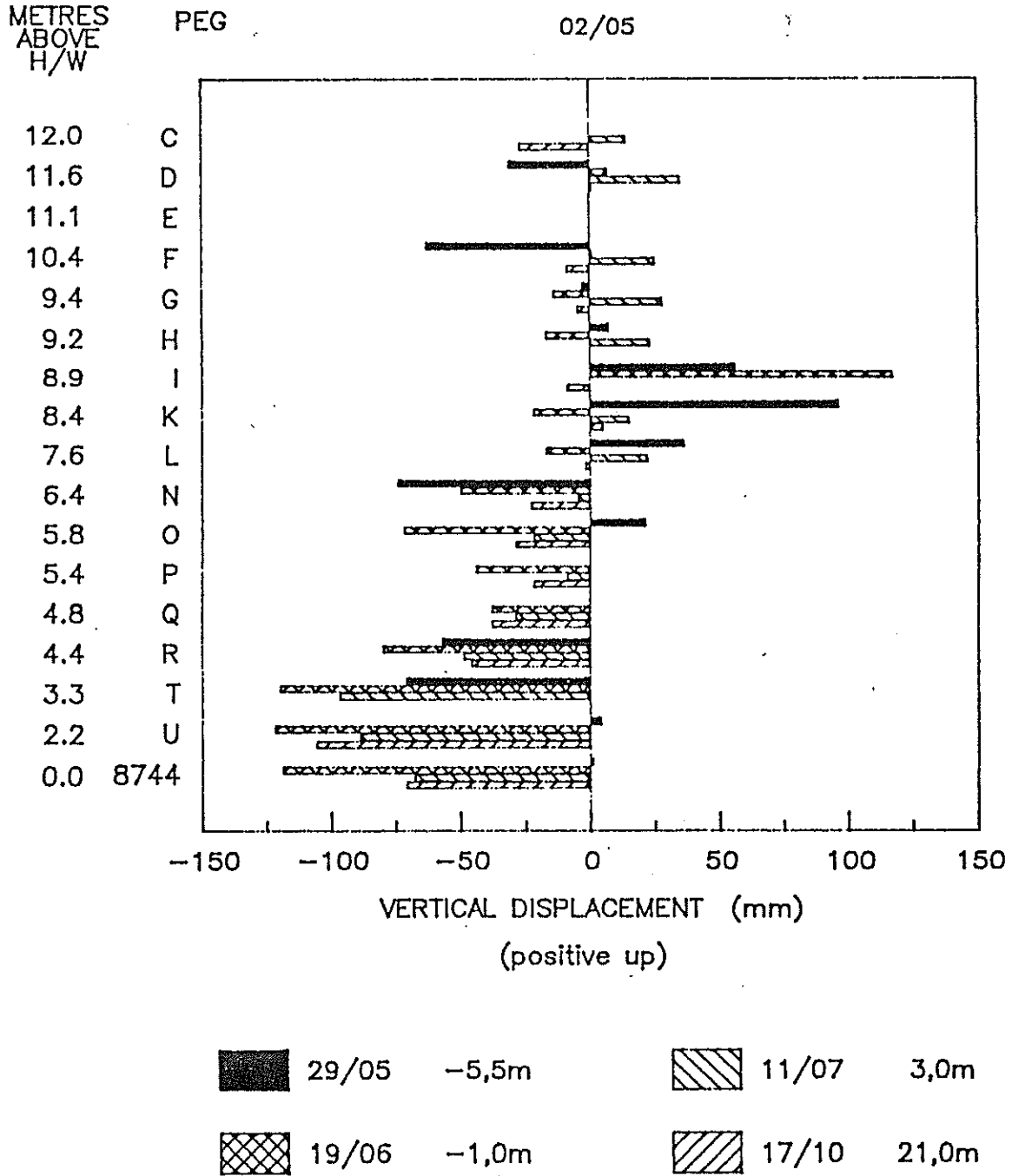

Figure 12 VERTICAL MOVEMENT IN THE RAISE RELATIVE TO PEG E

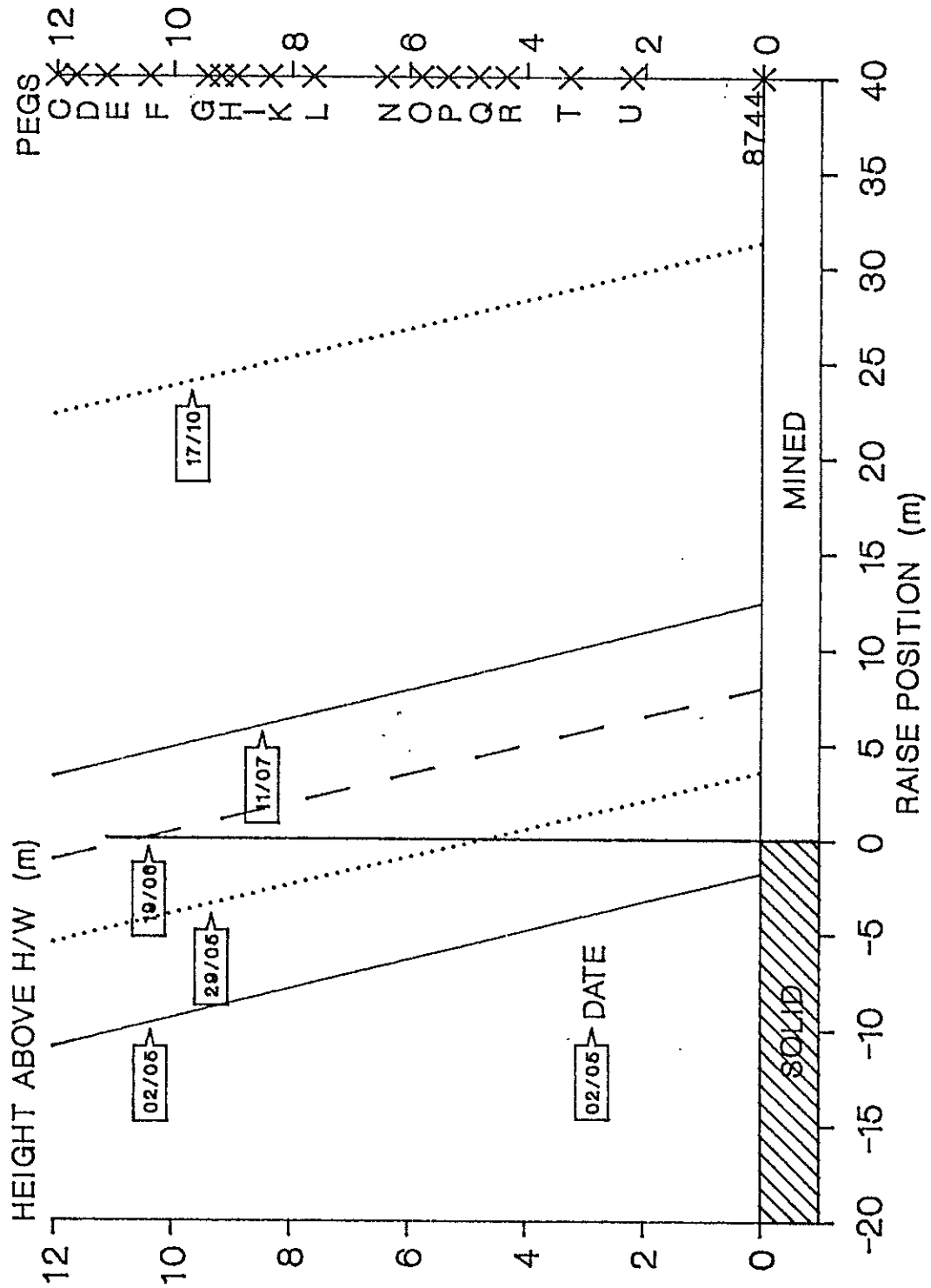

Figure 13 CHANGE OF RAISE POSITION WITH TIME RELATIVE TO FACE POSITION

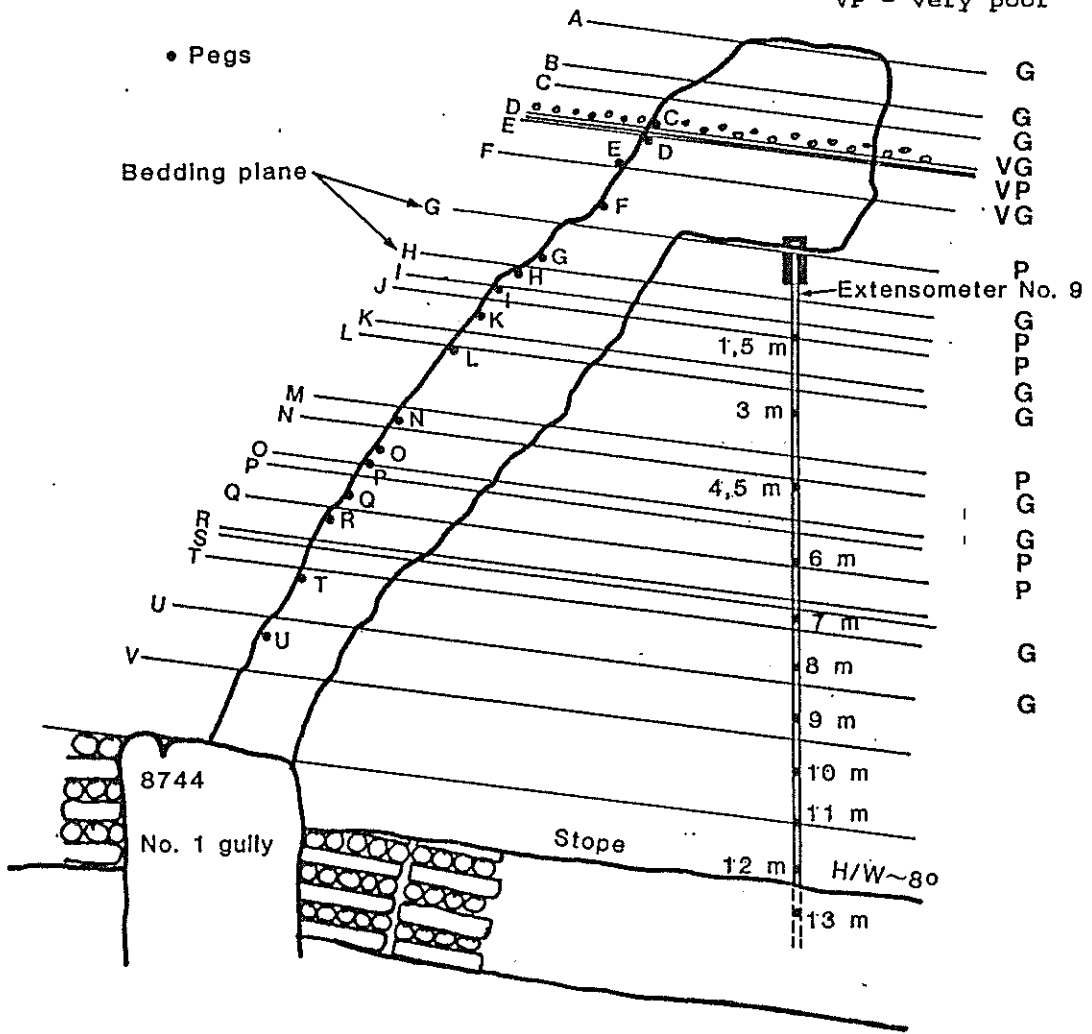
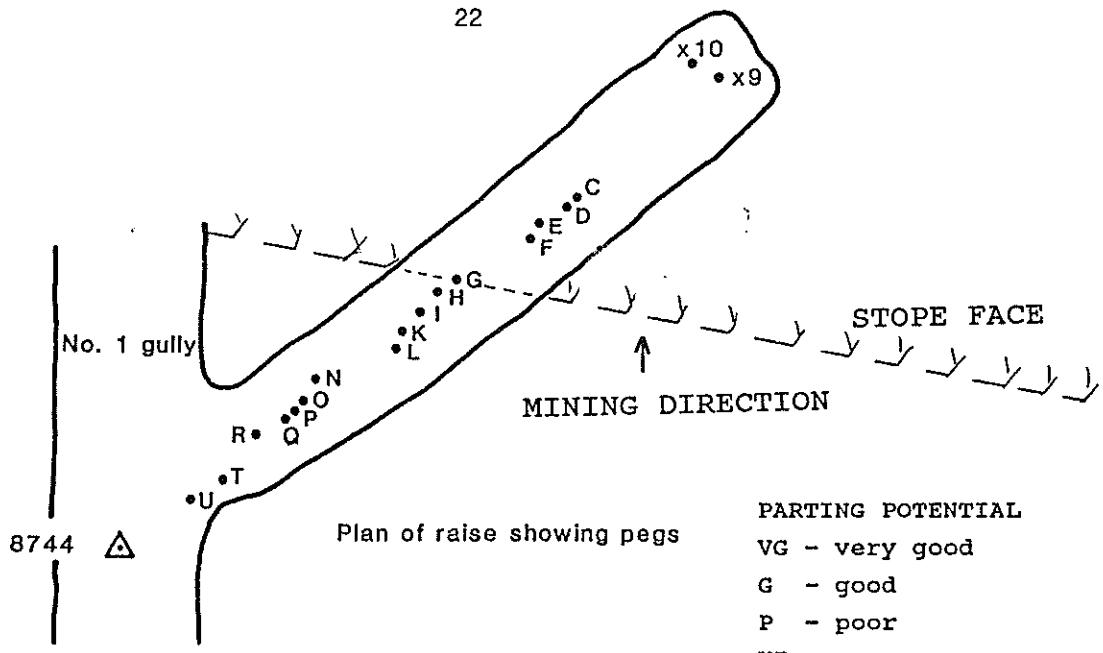

Figure 14 DIP CROSS-SECTION OF RAISE SHOWING BEDDING, PEGS AND EXTENSOMETER No. 9

3.3.2 Vertical movements

The vertical movement was mostly associated with, and roughly proportional to, shearing at the same position. The only exceptions to this were a large opening of 140 mm between pegs K and I (8,4 m and 8,9 m) and a corresponding closing between pegs I and H (8,9 m and 9,2 m) which had no corresponding shear movements and appear to be a buckling phenomenon.

3.4 Extensometer Measurements

Detailed results and Figures are given in Appendix V

3.4.1 Centre gully extensometers (Figures V.1 to V.6)

Extensometers 3 and 4 gave similar results, indicating parting or opening of the strata, especially those more than 5 m into the hangingwall. Extensometer 2, however, showed most of its movement as closure between anchors. The deformation rate for extensometer 2 was also substantially lower than that for the other two extensometers (0,04 mm / day compared with 2 mm / day).

3.4.2 Number 10 strike gully extensometers (Figures V.7 to V.18)

Extensometers 1, 1a and 13 installed within 2 m of the face acted similarly with substantial opening below 6 m and closing above 8 m. Extensometer 11, though, installed 12 m behind the face gave very different results, with only small amounts of movement mostly consisting of closure of the bedding planes.

The two footwall extensometers (12 and 14) also gave different results, both displaying only small amounts (10 mm to 20 mm) of closure. Extensometer 12 indicated mainly closing of the deeper beds with little movement near the footwall, while extensometer 14 indicated closing of the beds generally throughout its length with the major movements occurring near the footwall and between 14 m and 18 m.

3.4.3 Panel extensometers (Figures V.19 to V.26)

Extensometers 5, 7 and 8 showed comparable movements mainly taking place below 8 m, the lower beds generally opening the most.

Extensometer 6, however, reacted very differently with little overall extension of the hole but with opening of around 20 mm between 10 m and 7 m and corresponding closing between 4 m and 2 m.

3.4.4 Raise extensometers (Figures V.27 to V.29)

During the time the face advanced towards the raise extensometer 9 showed initial movement of the rock in the footwall of the reef was upwards and the hangingwall downwards towards the reef. The 13 m anchor in the reef also moved down more than 100 mm. Closure occurred between 1,5 m and 2,5 m into the hangingwall as the face approached the extensometer. Subsequently they moved apart as the face undermined then mined away from the extensometer. An opposing deformation was recorded between 2,5 m and 3,5 m above the reef where there was initial dilation followed by closing as the extensometer was undermined. Over 140 mm of opening occurred between 3,5 m and 5,5 m above the reef. The high rate of dilation started when the face was 4 m past the extensometer and continued while the face was advanced a further 10 m. The only other significant movements were an opening of 35 mm between 6,5 m and 8 m above the reef and within 1,5 m of the collar of the hole, 12,5 m above the reef.

3.5 Mining Induced Fracturing

Detailed results from the fracture surveys are contained in Appendix VII

3.5.1 Fractures related to previous mining activity

Previous mining of the 75/N/25 1 N panel had created strike parallel fracturing as much as 16 m down-dip into the 10 N panel.

3.5.2 Fracture orientation

In the experimental stope neither the fracture orientations nor the fracture spacings changed significantly once the 'cave' had been initiated.

The point at which the fracture inclination inflected from forward-dipping to backward-dipping located in the footwall of the stope both before and after caving. The fracture spacing before and after the cave showed a slight increase in average value from 208 mm to 232 mm.

4. DISCUSSION

4.1 Stope Closure

Measured stope closure, both at fixed geometric points within the stope, and in the advancing face area of the stope showed a large discrepancy compared to the convergence predicted by MINSIM simulations.

The closure rate profile in figure 9 shows a reduction towards the solid abutment which would be expected with any support system. There is a very small difference in real effect on the closure between the two very different support resistances if the effect of the abutment is discounted. This means that the inelastic closure is driven by large forces and is, in effect, 'irresistible' to conventional support in the working area. This means that support for deep stopes needs to be selected in terms of its resistance to deformation rather than just its strength. The support needs to carry only the immediate hangingwall in aseismic areas (a support resistance of 50 kN/m² has been recommended as suitable for most cases), but has to remain competent through a sufficient deformation to protect the workforce. This deformation can be of the order of 30% or more in areas with a high closure rate.

4.1.1 Stope closure rate in the working area

The stope closure rate in the working area decreased with increasing mining span and decreasing remnant span, Figures 6 and 7. An elastic analysis such as MINSIM shows that with increasing stope span the rate of convergence in the stope face area should increase. By reducing Young's Modulus substantially for MINSIM runs, theoretical convergence can be made to approximate measured closures, but it cannot simulate

convergence rates that decrease with increasing span. Therefore, an explanation of this phenomenon based on elastic theory is inappropriate and some other mechanism must be involved.

It is postulated that the intensity of fracturing and shearing and the associated dilation of the fracture zone ahead of the stope face contributes to the amount of inelastic closure in the stope face area, i.e. the more fracturing and shearing, the more horizontal dilation and shearing on bedding planes. If this is so then fracture generation and dilation must have decreased with the decreasing remnant span to account for the reduction in the rate of stope closure in the face area. This appears anomalous as increasing span and smaller remnant size should, theoretically, lead to higher stress levels and ERR values, and, therefore, more fracturing. There are three possible reasons for a reduction in fracturing and deformation:

- (i) The fracture zones of the two faces mining on opposite sides of the remnant coalesced and the formerly elastic rock material in the core of the remnant, between the two fracture zones failed partially by fracturing. If this is the case the remnant is stress relieved and has a decreasing ability to fracture and cause dilation ahead of the stope face as its size is further reduced by mining. Consequently there is a decrease in the rate of stope closure. Consideration of Figures 6 and 7 shows that the decrease in the stope closure rate was evident from the beginning of the closure monitoring period, except for the two peg lines either side of 10 N gully, when the remnant was 36 m wide at the 10 N panel position and 26 m wide at the 9 N panel position. It must, therefore, be assumed that the remnant was shedding stress to abutments and surrounding closed areas as it was so fractured as to be unable to accept any increase in load.
- (ii) The 'caved' material in the back-areas of the stope panels has bulked and reconsolidated allowing closure to occur in the back-areas of the stope with a consequent reduction in the rate of stress increase in the face abutment. This is not an entirely satisfactory explanation as the stope closure rates in the face would be expected to stabilise when closure occurs and thereafter the closure rates should remain constant with increasing stope span only if the stope is mining towards the solid not towards a remnant as in this case.

(iii) A combination of (i) and (ii) above.

No investigations were carried out on the depth of fracturing ahead of the faces of these panels and, therefore, the cause of the decrease in the rate of stope closure can only be surmised as above.

4.1.2 Time dependence

From Figure 9 it can be seen that the closure rate in panel 9 N didn't tail off after the end of blasting in the panel. The longer period of high closure rates is probably accounted for by the continued mining in panel 10 N. The long period of time dependent closure was surprising but was confirmed by measurements taken in the south panels where high rates of closure persisted for a similar period after mining had ceased.

4.2 Movement on Bedding Planes

4.2.1 Shearing

Differential movements across weak bedding planes in the stope hangingwall have been observed at many stoping locations. The raise developed ahead of the 10 N panel offered a unique opportunity to determine the magnitude, sense and location of this shearing, both before, during and after undermining of the raise.

There is substantial evidence from the raise which correlates the shearing of bedding planes in the hangingwall to the measured vertical dilation and thus the large component of measured inelastic closure in the stoping excavation, Figures 10 to 12. The raise showed that the larger vertical displacements usually coincided with the larger shear displacements.

Most bedding planes are non-planar both on a small and a large scale. Structures such as ripple marks could be considered small scale, whereas undulations with wavelengths of several metres would be considered large scale. Clearly, shearing across such non-planar features would cause associated vertical opening of the bedding planes in the hangingwall and footwall while the bedding planes rode over these structures as shown in Figure 15. Moreover the implication of this mechanism is that part of the vertical dilation in the stope hangingwall and footwall caused by the undulations is largely irreversible. Once the shearing across bedding planes has occurred, some areas of the bedding planes will

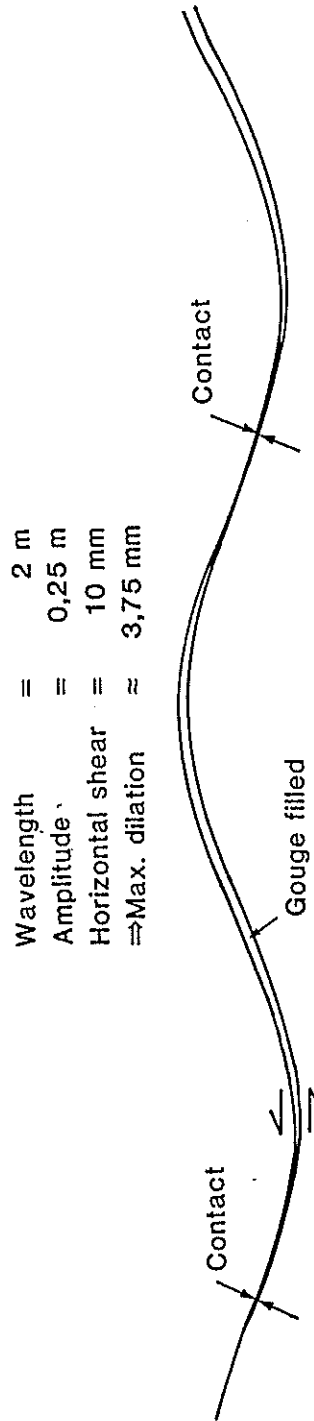

Figure 15 DIAGRAM OF VERTICAL DISPLACEMENT CREATED BY HORIZONTAL SHEARING OF NON-PLANAR SURFACES

no longer be in contact, thus affecting the orientation and magnitude of the stresses within the hangingwall and footwall making it very difficult to obtain meaningful stress measurements.

4.2.2 Extension

The extensometers show effects such as apparently irreversible extension, even after total closure of the panels. Various discrepancies between apparently similar extensometers can usually be explained in terms of different geometries of mining or support, for instance the difference in results from extensometer 2 and extensometers 3 and 4 is due to the pre-existing large (30 m +) span when extensometer 2 was installed while the other two were installed when the faces were only at the end of ledging. This suggests that significant closure had occurred before extensometer 2 was installed and is backed up by the substantial difference in closure rate between the extensometers.

4.3 Hangingwall Dilation

Hangingwall dilation was recorded up to 16 m above the stoping horizon and at various points between.

If it is assumed that at least half the recorded closure is contributed by deformation of the hangingwall then an analysis of the data plotted in Figure 16 is of significance. The figure compares the hangingwall vertical dilation or bed separation as measured by extensometer 4, drilled from the centre gully, to half the closure recorded in the stope at the position of the extensometer. Up to a distance of 55 m from the face the closure is greater than the dilation measured by the extensometer. With further face advance the rates of closure and dilation are markedly lower and are about equal. Curve C is a plot of the difference between the closure and dilation.

The most likely explanation for the discrepancy is that bed separation extends higher into the hangingwall than the 13 m of strata monitored by the extensometer.

The other effect that this indicates is that total closure of the stope occurred after 55 m of face advance effectively preventing further dilation of the strata.

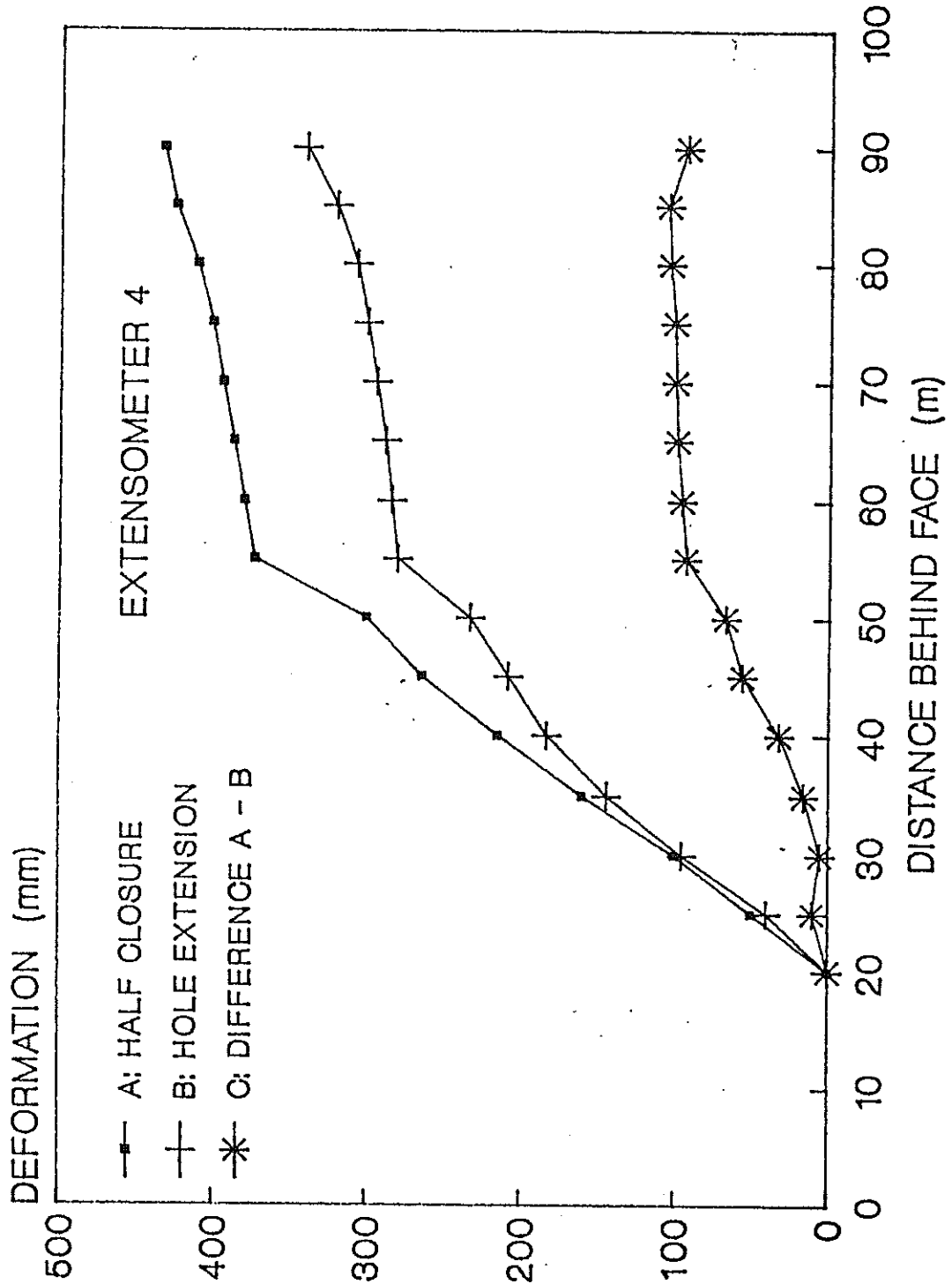

Figure 16 HANGINGWALL DILATION NOT MEASURED BY THE EXTENSOMETER

Extensometer data shows that a large portion of the vertical hangingwall dilation occurs at a height of between 8 m and 10 m. In practice drilling through this zone of the hangingwall was difficult and was accompanied by water losses. In one particular case the drilling water was dyed and observed to emerge from the stope hangingwall, close to the stope face, 30 m away from the drilling site. This suggests that at this height above the reef a major, weak parting plane occurs which correlates with the movement measured in the raise behind the face.

The extensometers installed in the raise and the results of surveys of the raise, showed that vertical hangingwall dilation first occurs in the fractured zone ahead of the stope face. It is believed that this is due, primarily, to the shearing across bedding planes, which is discussed in section 4.2.1.

4.4 Mining Induced Fracturing

The results of the fracture measurements did not conform with previous measurements which showed that after 'caving' many of the fractures in the hangingwall dipped in the opposite direction to that found in most conventional mining, that is they dipped towards the back area.

The fracturing in the experimental stope did not behave as do typical 'caved' stopes elsewhere on Hartebeestfontein. This could be due to:

- (i) different local geology;
- (ii) erratic rate of face advance and long delays incurred during the installation of instrumentation;
- (iii) different support systems used at this experimental site.

It was also clear that there was no decrease in the number of potentially unstable face parallel prisms of rock in the hangingwall (Appendix VII), nor any decrease in the angle subtended by upward convergent adjacent fracture planes. The reason for the lack of significant change is not readily apparent. It is significant that the inflection of the fractures remained in the footwall of the stope when the stope face had advanced 16 m after the initiation of the 'cave'. This is contrary to experience in most other caving panels on the mine where the inflection of fractures moves upwards into the hangingwall.

Typical phenomena attributed to caving were observed in the previously mined 75/N/25 1 N panel directly above the 10 N panel. It seems likely, therefore, that the conditions for normal 'caving' were not achieved on the 9 N and 10 N panels. This was most likely due to the frequent stopping of the face necessary for drilling instrumentation and observation boreholes.

It should be noted, however, that at times the hangingwall would hang-up for 10 m or more on strike, and require blasting down to induce the cave. This suggests that the immediate hangingwall can adequately support itself, requiring only minimal support to carry keyblocks.

5. CONCLUSIONS

The stope did not behave in the way which is considered typical of a 'caving' stope, therefore, conclusions regarding the behaviour of the surrounding rock in respect to 'caving' should be tentative only.

However, the experiment has provided very valuable information regarding the movement of the rock mass immediately surrounding the stope. The cross raise especially has produced quantitative results on bedding plane slip and associated vertical displacement allowing a tentative conceptual model to be developed (Section 5.1), and the following conclusions to be drawn:

1. A large component of inelastic closure is due to high horizontal forces, created by fracturing ahead of the face, causing slip on hangingwall-parallel discontinuities.
2. The slip on bedding planes creates areas of no contact and areas of contact through which high stresses are transmitted. This causes a very irregular stress distribution in the hangingwall making it very difficult to achieve meaningful stress measurements.
3. Closure in the working area is largely unaffected by conventional support types.
4. Support must be selected on its ability to withstand large deformations and not only on its load bearing capacity.
5. Time dependent stope closure has been found to be a marked phenomenon at this and several other sites, and should be considered whenever faces which use a

support with limited deformation capabilities slow their face advance or are stopped for some time.

6. The drop in closure rate as the remnant size decreased below 30 m could have serious implications for the design of regional pillars if it indicates complete fracturing of the remnant pillar.

5.1 Conceptual Model

The conclusions drawn from this experiment and previous work has allowed a conceptual model to be developed of the rock behaviour surrounding the stoping horizon. This model attempts to explain the high rates of closure in the stoping excavation in terms of bedding plane shear and consequent vertical dilation of the hangingwall and footwall. The stress induced fracturing and consequent horizontal dilation ahead of the stope face gives rise to high horizontal stresses in the face area which causes the bedding plane shear and possible flexing of the hangingwall strata.

Figure 17 is a diagram showing the proposed physical causes of the observed behaviour of the rock mass. The three main features of the model are the development of fractures, the slip on the bedding planes and the consequent hanging wall dilation.

There are two distinct fracture types; primary, shear fractures and secondary, extension fractures which have been described elsewhere (Brummer and Rorke 1984), (Gay and Jager 1986).

The slip on bedding planes and horizontal discontinuities has been documented before (Legge 1986), however its importance regarding stope closure appears not to have been recognized. The cause of the slipping or shearing on bedding planes is postulated to be the differential horizontal dilation produced by the primary shear fractures and secondary extension fractures ahead of the face. This dilation creates high horizontal stresses and forces the hangingwall downwards and the footwall upwards into the stope. Associated with this is a buckling action of the lower beds due to the low normal restraint, which occurs because the support is unable to resist the forces induced by the horizontal stress. The thickness of this first 'beam' at Hartebeestfontein appeared to be of the order of 8 m to 10 m. Similar 'beam' thicknesses have been observed elsewhere.

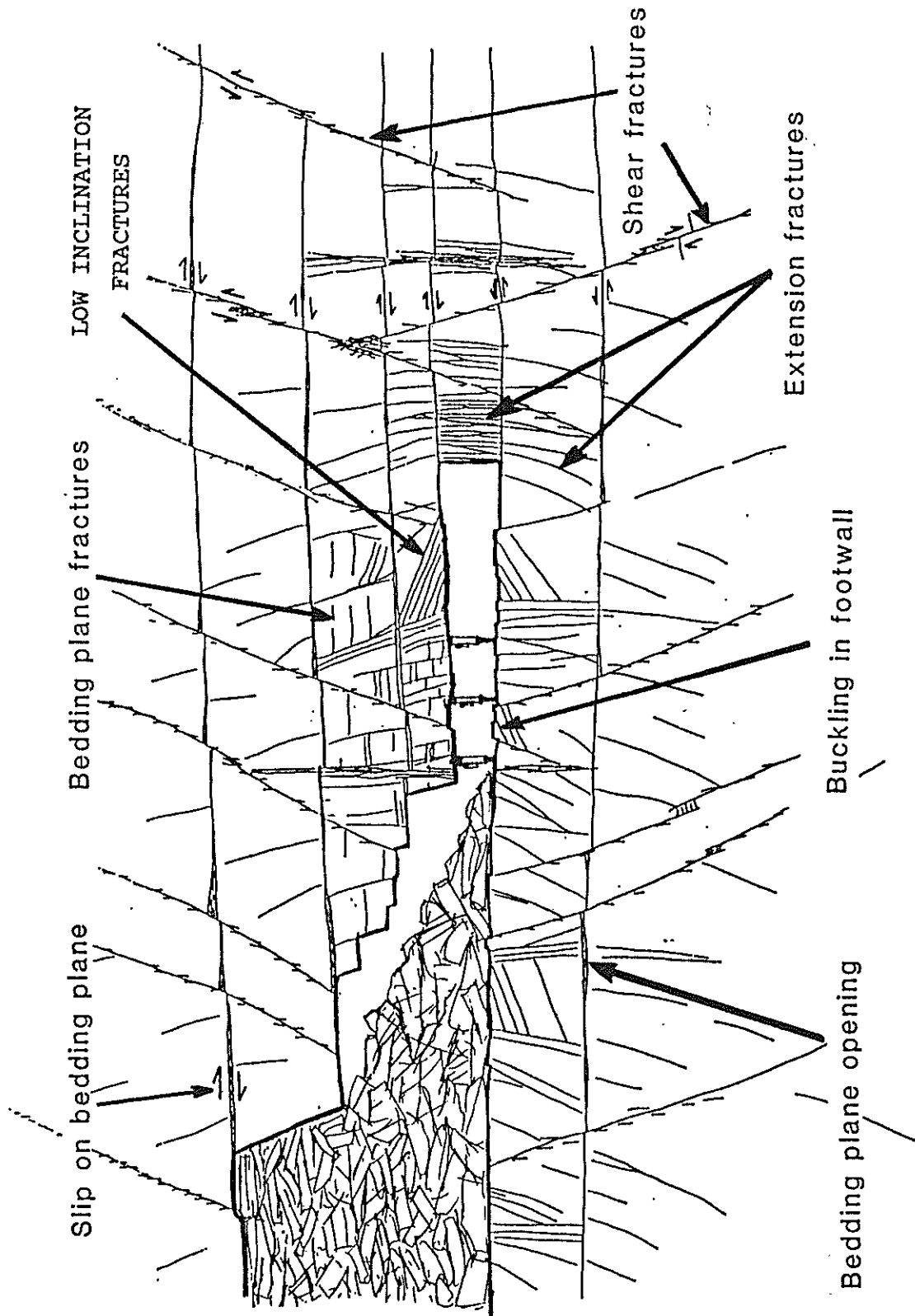

Figure 17 CONCEPTUAL MODEL OF FRACTURING AND DEFORMATION
AROUND A DEEP GOLD MINE STOPE

This 'beam' action, however, must not be confused with the support resistance requirement of around 50 kN/m², as the 'beam' is usually competent to carry its own weight. The support is only required to carry the first one to two metres of hangingwall which is sufficient to preserve the integrity of the main 'beam'.

The shear on the bedding planes creates some areas of contact across their surfaces, as well as other areas in which little or no contact is present across the beds, through which vertical stress can be transmitted. Figure 18 shows this effect schematically. Clearly this action must cause very irregular stress distribution throughout the immediate hangingwall and the implication with respect to computer modelling is still to be investigated. This could also be a contributory factor in 'hard patch' formation. The effect of the time dependent behaviour of the rock cannot be shown in this model. This phenomenon is important, however, and can be defined as the time taken for the rock mass around the stope to deform and reach equilibrium, probably over several weeks.

6. RECOMMENDATIONS

- 1 Future fracture studies related to the influence of caving should be conducted to determine the effect of the above factors on fracture formation in caving production stopes.
- 2 Further investigations into the relationship between face fracturing and deformation in and around stoping excavations should also be undertaken.
- 3 Work is also required to determine the proportions of closure contributed by the hangingwall and footwall.
- 4 At present, the time dependent behaviour of the rock mass around stoping excavations is not well understood and requires further research.

7. REFERENCES

BASSON, H., GAY, N.C., JACK, B. and WAGNER, H. (1984). The performance of rapid-yielding hydraulic barrier props as stope support in a deep level mine. Research Report No. 13/84, Chamber of Mines of South Africa, Johannesburg.

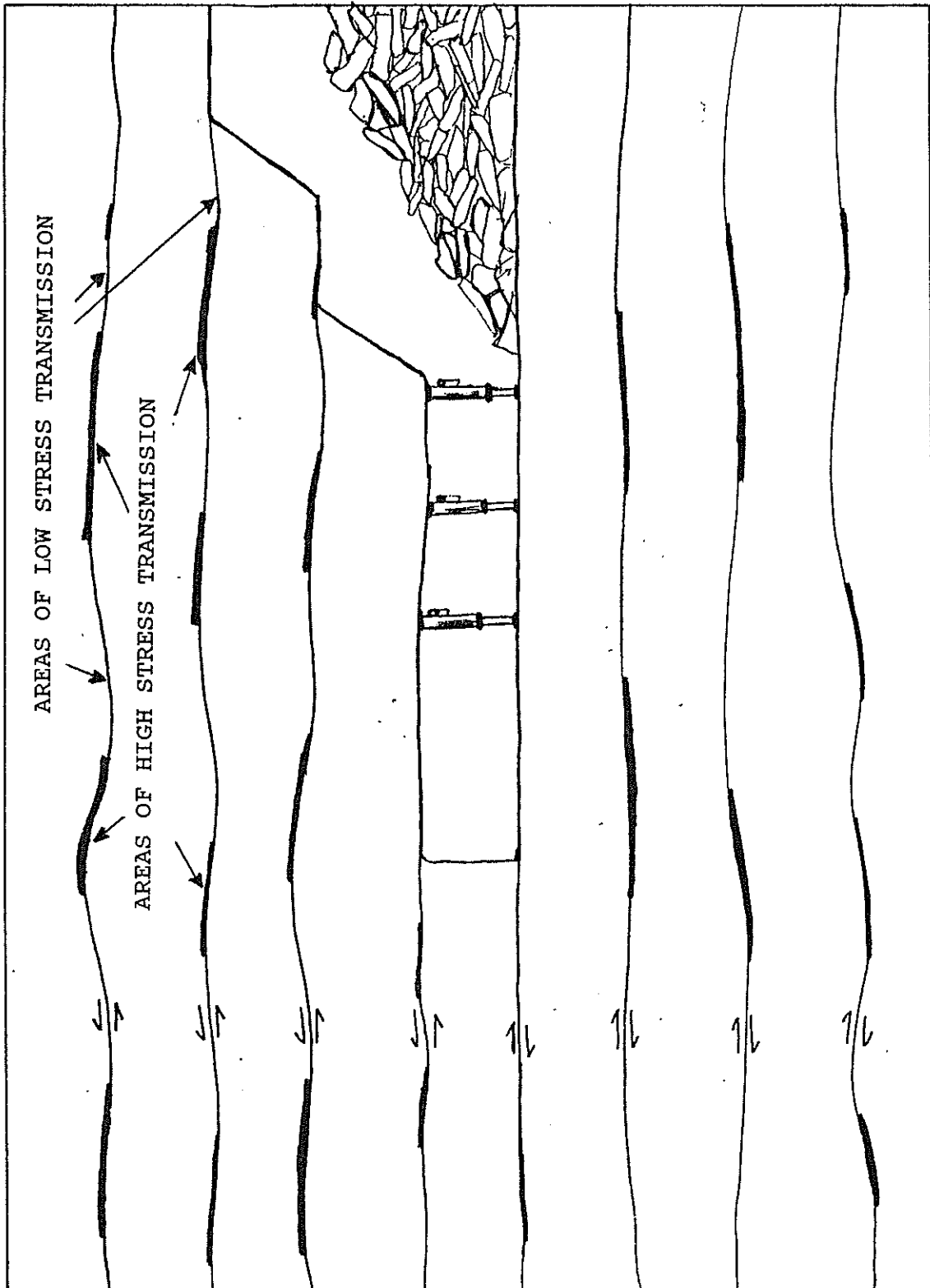

Figure 18 EFFECT OF SHEARING ON BED SEPARATION AND AREAS OF CONTACT

BRUMMER, R.K. and RORKE, A.J. (1984). Mining induced fracturing around deep gold mine stopes. Research Report No. 38/84, Chamber of Mines of South Africa, Johannesburg.

GAY, N.C. and JAGER, A.J. (1986). The influence of geological features on problems of rock mechanics in Witwatersrand mines, in: Mineral Deposits of Southern Africa, eds. C.R. Anhaeusser and S. Maske, Johannesburg, Geological Society of South Africa, 1986, pp.753-772.

LEGGE, N.B. (1986). Rock deformation in the vicinity of deep gold mine stopes and its relation to fracture. Research Report No. 14/86, Chamber of Mines of South Africa, Johannesburg.

APPENDIX I

'CAVING' THEORY

When the hangingwall is allowed to collapse behind the well supported working area, certain modifications of the stress distribution occur which modify the fracture geometry. These modifications are purported to have a beneficial influence on the hangingwall stability.

The inflection of the fractures is seen to occur near what seems to be a plane of symmetry, parallel to the stope plane and at a level approximately at the mid-height of the effective stope width.

In a normal stope this inflection occurs at the footwall due to the presence of footwall dip gullies (Figures I.1a and I.2a). Remote from these gullies, their effect dies out and the inflection moves into the plane of the stope (Figure I.1b). These inflections are often exposed in the gully sides (Figure I.2a).

In a 'caving' stope the plane of symmetry is thought to be displaced into the stope hangingwall due to the increase of the effective stope width as a result of the 'cave' (Figure I.1c and I.2b). Where the 'cave' has not extended high above the stope, the inflection may be exposed by fall-out in the near hangingwall (Figure I.2b). Due to the change in the stress profile the fractures in the immediate hangingwall dip towards the mined-out area, resulting in a more favourable geometry.

It has also been observed that, as a result of 'caving', the spacing between face-parallel fractures increases after the initiation of the 'cave' and drilling of the face is much easier because the stress level at the face has reduced and less slabbing occurs. Face-parallel fractures ahead of the stope were reported to extend to between 4,5 m and 5,5 m ahead of uncaved stopes, as against 7 m to 9 m ahead of caved stopes (Deacon, 1965).

The reduction of stress on the stope face may be attributable to reduced confinement of the rock ahead of the face, due to the larger void which it has to move into. This relaxation of horizontal confinement would allow fracturing to occur further ahead of the stope (as has been observed), which would, in turn, move the stress concentration further ahead of the face. This would result in a lower, broader stress abutment ahead of the face.

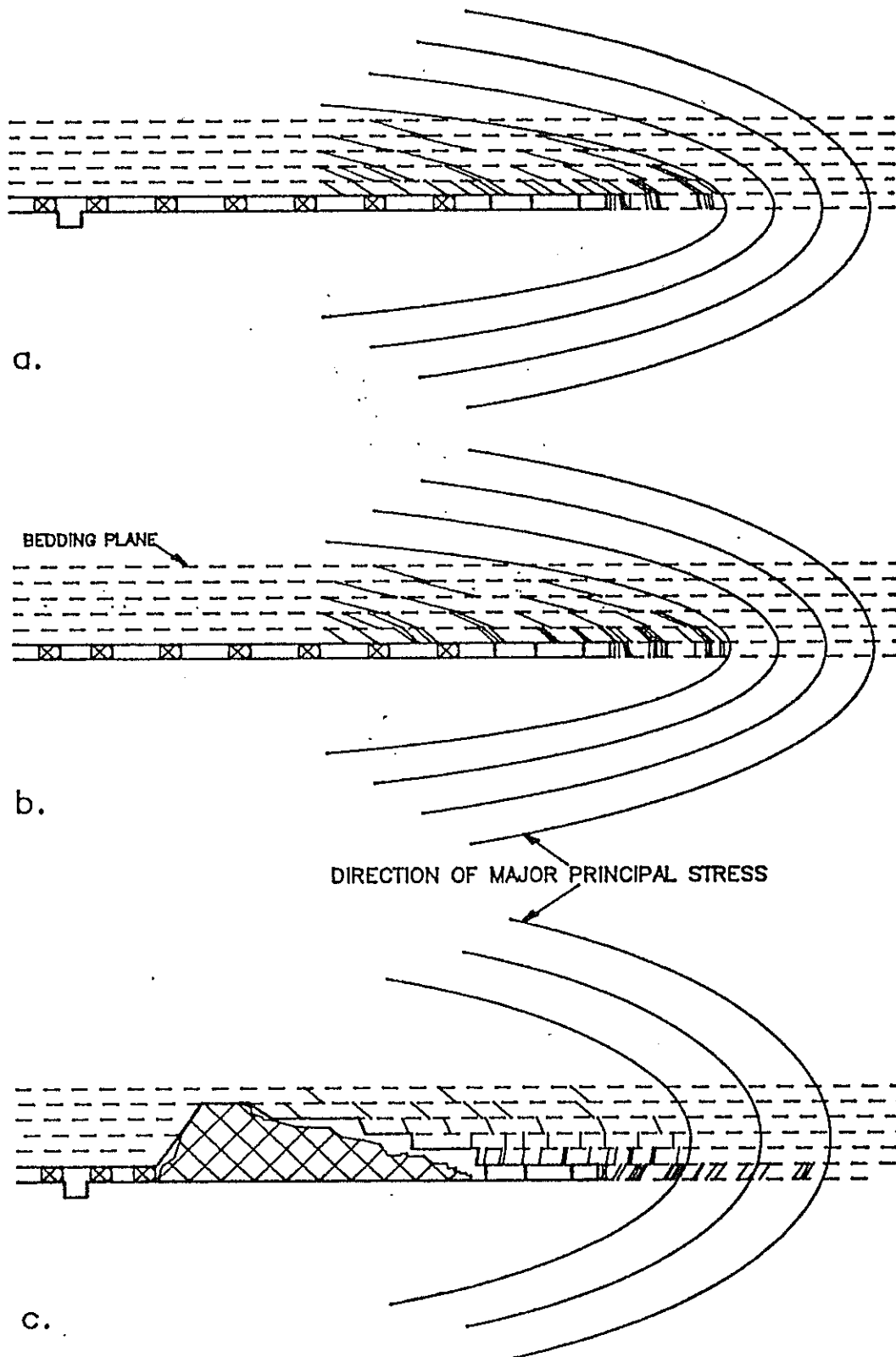

Figure I.1 a. FRACTURE DEVELOPMENT AROUND A NORMAL STOPE
b. REMOTE FROM THE DIP GULLY
c. FRACTURE DEVELOPMENT AROUND A 'CAVING' STOPE

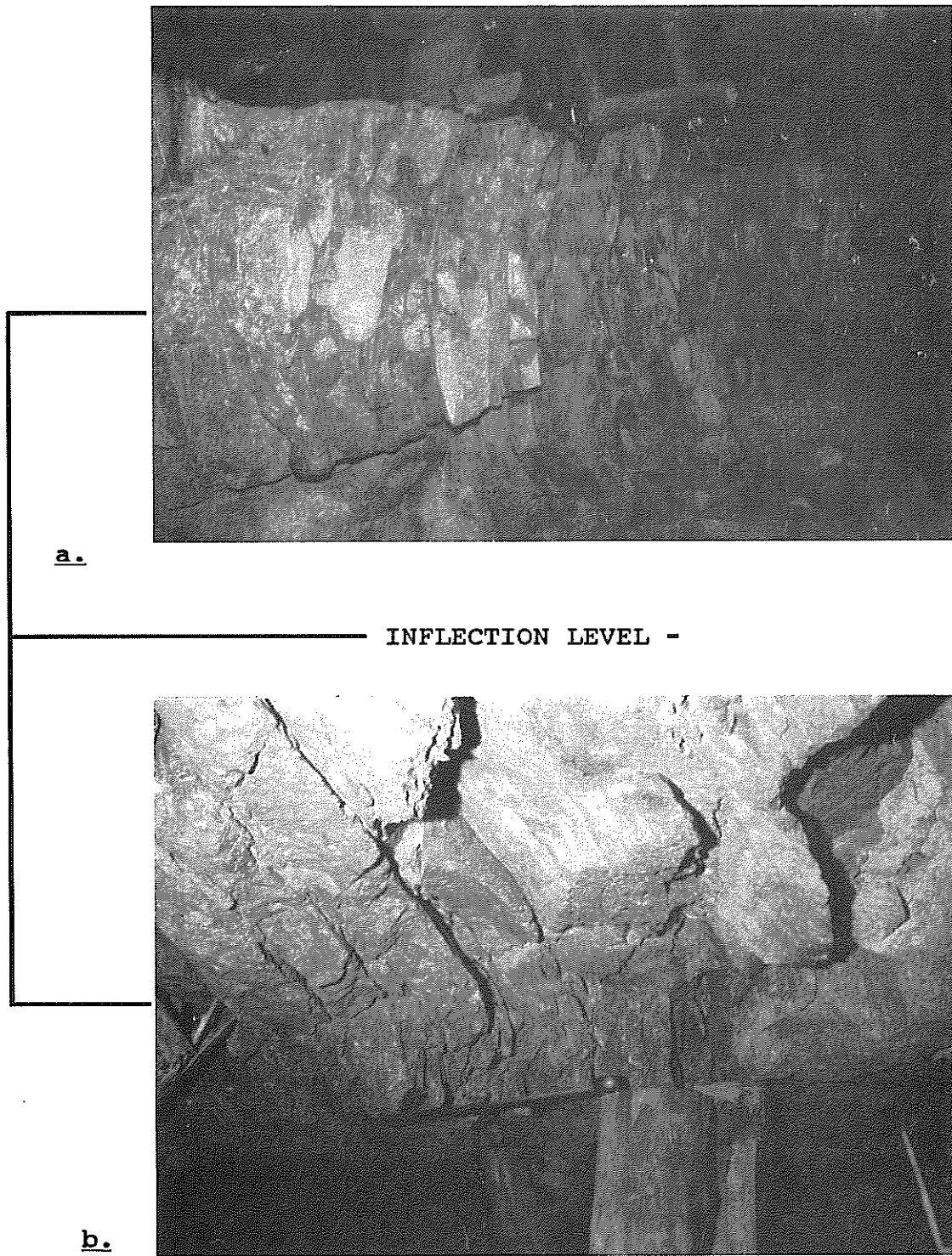

Figure I.2 a. INFLECTION OF FRACTURES IN THE FOOTWALL
b. INFLECTION OF FRACTURES IN THE HANGINGWALL

An important result of caving the hangingwall of a stope with no back-area support is that the caved material provides support to the hangingwall a certain distance back from the last row of support. When the rock caves it occupies roughly 1,5 times its original volume, depending on the size and grading of the blocks. If the hangingwall caves to a height of twice the original stoping width, the broken rock will, theoretically, fill the entire void, providing some immediate support and preventing further falls of rock. As closure occurs the rock will be compressed acting as backfill. The load / deformation characteristic of the material is very unpredictable due to the wide variation in possible block sizes and grading.

REFERENCE

DEACON, D.D. Stopping at Zandpan, Papers and Discussions, The Association of Mine Managers of South Africa, 1965.

APPENDIX II

THE STICK SUPPORT SYSTEM

II.1 Background

A considerable amount of mining with no back area support has been carried out at Hartebeestfontein Gold Mine. The support system used was 150 mm to 200 mm diameter mine poles, spaced 1,2 m apart on strike and 1,2 m on dip. Five dip rows of these mine poles were used of which the back row was blasted out as the face advanced and a new row was installed between 2.5 m and 3.5 m from the stope face. Monitoring of the performance of the support system was carried out to guide the design of the experiments described in this report.

II.2 Instrumentation

Electronic load cells were installed under several of the sticks, with closure pegs beside them. Both closure and force on the sticks were measured as the face advanced away from them. In this way, a load cell installed in the first row of support, closest to the face, subsequently was situated in the second, third, fourth and fifth row where the stick was blasted out. In this way, force / deformation curves for individual sticks were determined as were force / deformation behaviour of each line of sticks.

II.3 Support Resistance

The overall support resistance of the system is approximately 28 kN/m² but this is unevenly spread over the supported area as shown in Figure II.1 which compares this support resistance with the two support systems used in the experimental stope.

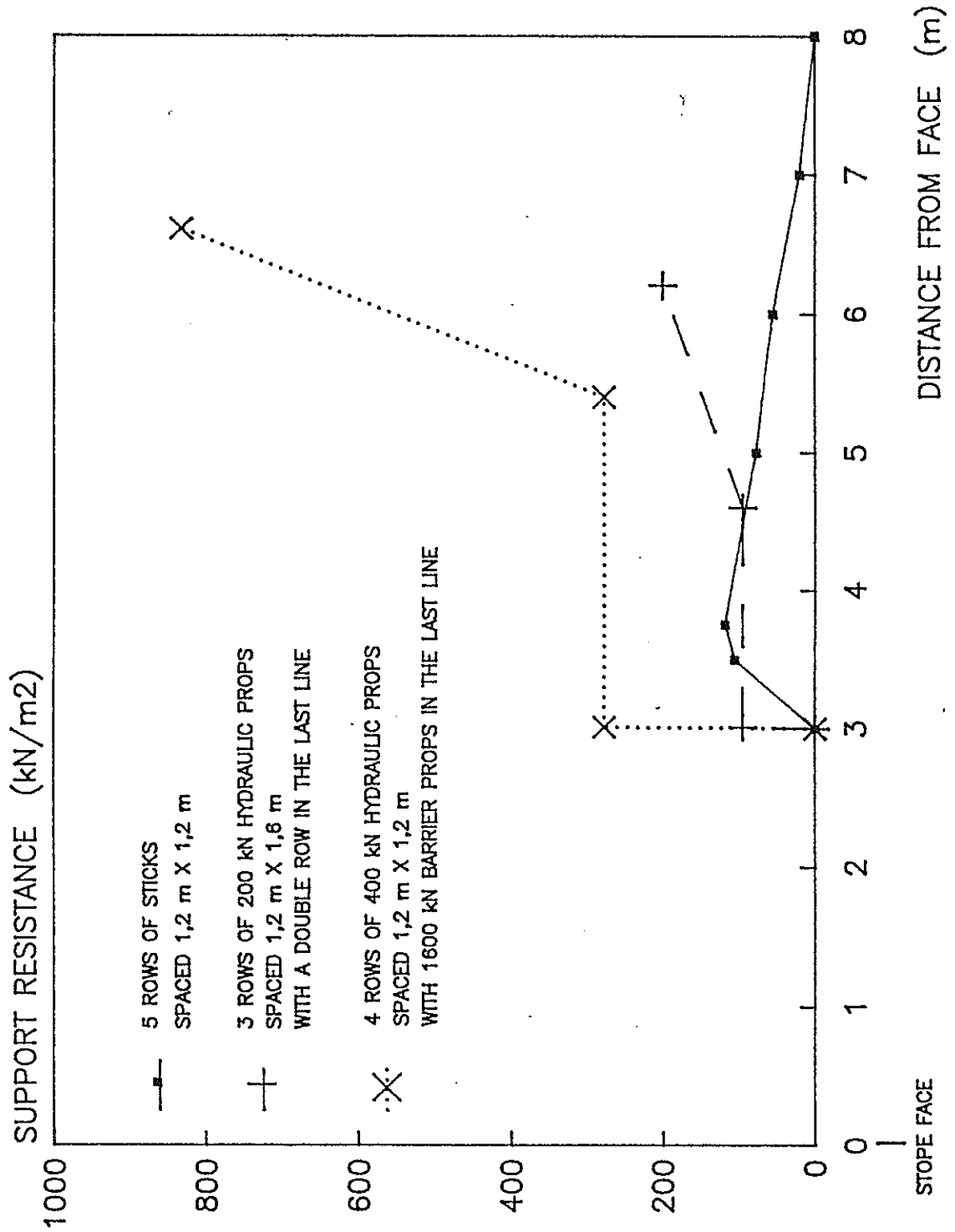

Figure II.1 COMPARISON OF SUPPORT RESISTANCE FOR THE DIFFERENT SUPPORT SYSTEMS

APPENDIX III

GEOLOGY

The Vaal Reef is overlain by 1 to 1,5 m of siliceous quartzite (90 % quartz content with few bedding planes). At the top of this quartzite is a 0,1 m pebble band, the Zandpan marker, which is overlain by quartz wacke (60 % quartz, 40 % micas and clays). This quartz wacke is well bedded with the beds ranging in thickness from 0,1 m to 1,3 m. The lowermost units are generally upward fining with micaceous mineral contents increasing to 80% in their upper 0,1 to 0,2 m. The tensile strength perpendicular to bedding decreases from 12 MPa in the lower portion of these beds to 2,5 MPa in the micaceous portions.

In the 15 metre section of the hangingwall that was exposed in the raise developed from the N 1 gully over 10 N panel, fissile partings were present with separations of 0,1 to 1,3 m (mean 0,8 m).

Mapping of hangingwall exposures in the original 77 N 25 raise revealed some information on the persistence and variability of the bedding plane partings in the lower 2 m of hangingwall rock. Most of the partings were very impersistent.

There were few joints in the hangingwall. Four sets of joints were observed with strike directions of 45°, 73°, 102° and 122° clockwise from the reef dip direction. The respective dips were; 42° to 70°, 70° to 75°, 56° to 78° and 67° to 76° all in a down dip direction.

No prominent faults were intersected during the mining of the two panels.

APPENDIX IV

INSTRUMENTATION

IV.1 CLOSURE MEASURING STATIONS

These consisted of a pair of pegs, one attached to the hangingwall and one to the footwall, in a line normal to the plane of the reef. The distance between the pegs was measured using a millimetre graduated tape. Each extensometer included associated closure stations and each of the two panels contained four strike lines of closure stations to determine the rate of stope closure in the working area. These stations were installed roughly 2 m from the face and were read on a daily basis until the station was lost in the 'caved' area.

During the advance of the 10 N and 9 N panels, closure pegs were installed in the hangingwall and footwall to within 2 m of the stope face. As the stope face advanced the closure was measured at regular intervals until the pegs were lost in the 'cave', usually 7 m to 8 m behind the stope face. In practice these pegs were installed after approximately every 2 m of face advance and there were, therefore, two or three of these closure stations exposed at any one time in the stope face area giving a continuous strike line of closure stations (Figure IV.1). In each of the two panels, four such strike lines of closure stations were established. These strike lines effectively determine the stope closure in the working area as the stope advances.

IV.2 CONTINUOUS CLOSURE METERS

These consisted of two concentric tubes, the upper one fitting inside the lower. A lever with a scribing point locates in a collar fitted to the upper tube and records the movement of the tube on pressure sensitive paper attached to a drum. The drum is fitted to a clockwork motor which could be set to record closure for periods of one day or seven days. The tubes are located against the rock using putty and are prevented from dropping inside each other by a friction device. Their main purpose was to record changes in closure rates due to the mining and especially those caused by blasts.

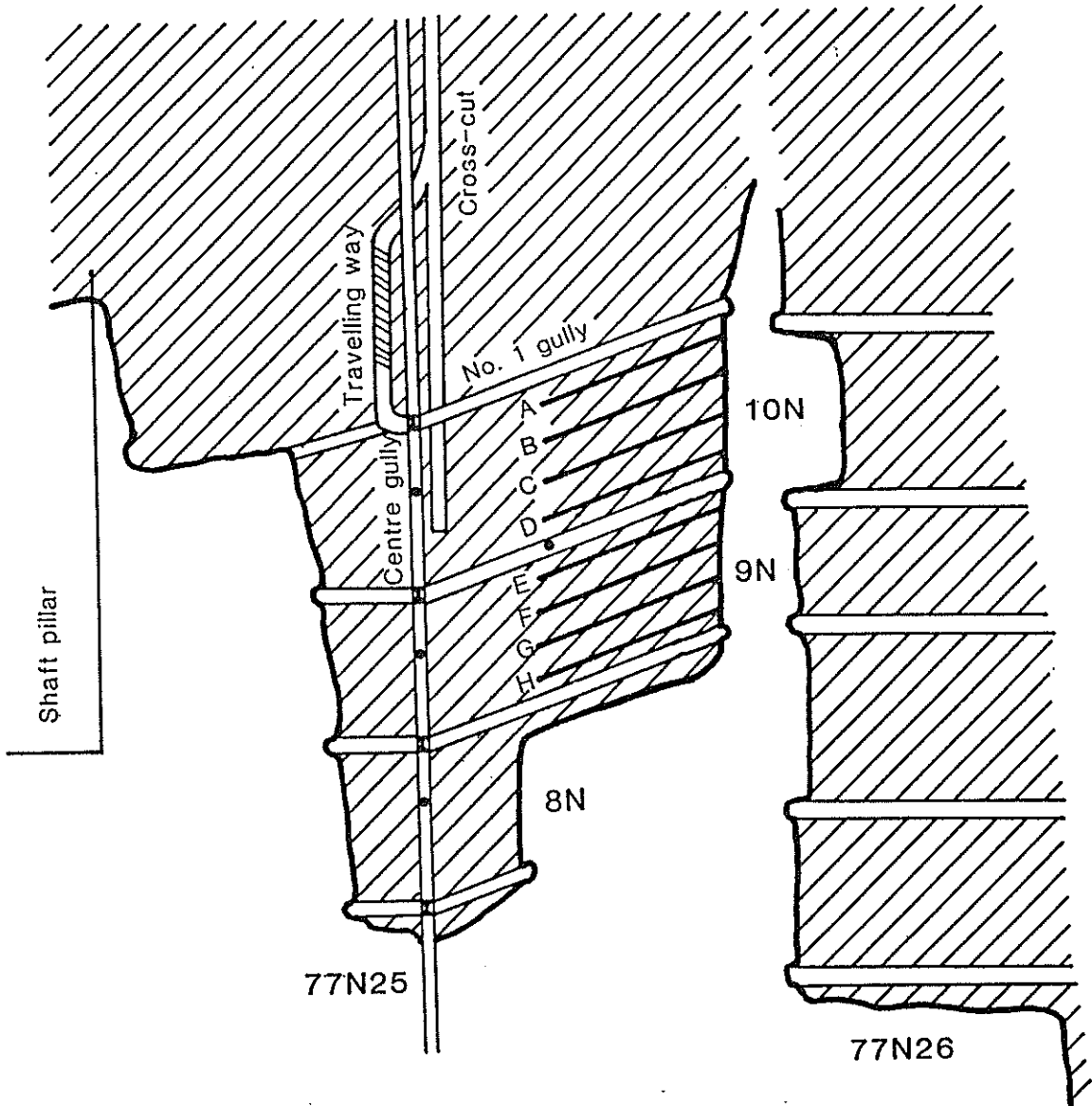

A-H, strike lines of closure stations

Scale \approx 1:1250

Figure IV.1 POSITION OF THE LINES OF CLOSURE MEASURING PEGS

IV.3 RAISE

The flat portion at the top of the raise was 12,5 m above the hangingwall of the stope and 10 m in from the side of the gully. The two extensometers, 9 and 10, were installed down from the top of the raise to intersect the reef horizon. In the hangingwall of the raise, from the gully to where the raise flattened out, the stratigraphy of the raise was mapped and pegs were installed to monitor the movement of individual beds (Figure IV.2). The pegs were surveyed at one to two week intervals throughout the mining of 10 N panel from 5 m before the face reached the bottom of the raise to 21 m beyond. The raise was geologically mapped before the pegs were installed to ensure their placement either side of prominent partings.

The pegs and extensometers in the raise were monitored regularly from 11 m ahead of the face until the mining was completed on the 10 N panel, at which stage the face was 21 m past the raise. Pegs were installed in most of the individual beds and were surveyed using a one second theodolite and plumb bobs attached to each peg in turn. A backsight was used in the number one gully towards the centre gully. This backsight was checked before the monitoring started, after it had finished and from time to time during the life of the raise. The total movement of the peg at the bottom of the raise relative to the top of the entry travelling way was 0,188 m.

IV.4 EXTENSOMETERS

The main form of instrumentation at the site was wire extensometers. These comprised from five to eight spring anchors which were installed at various heights in BX boreholes. Eight gauge wire with 300 mm of measuring tape attached to one end was fixed to each anchor, enabling readings of movements to an accuracy of one millimetre. A borehole cap, which consisted of a steel pipe with a base plate and cover flap, was wedged into the collar of each hole to provide a datum against which to read the tapes and also to protect them.

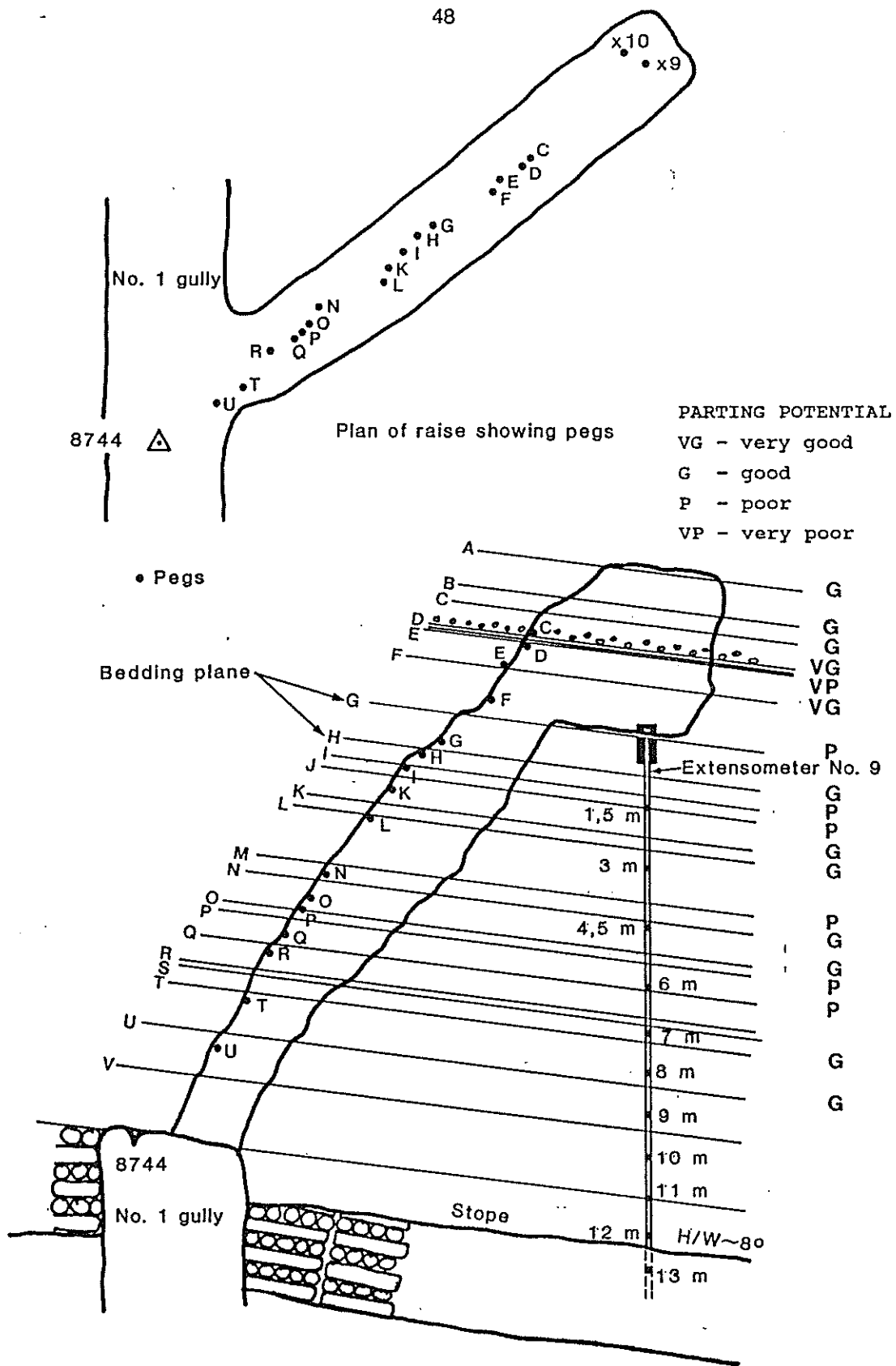

Figure IV.2 DIP CROSS-SECTION OF RAISE SHOWING BEDDING, PEGS AND EXTENSOMETER No. 9

APPENDIX VEXTENSOMETER RESULTS

In all the figures the extensometer movements are plotted relative to the deepest anchor. The line for this anchor follows the horizontal axis of time or distance. The figures are plotted this way to avoid discrepancies caused by movement of the collar of the hole. To interpret the figures any movement down relative to a deeper anchor indicates opening and any movement up relative to a deeper anchor indicates closing between the anchors.

V.1 CENTRE GULLY EXTENSOMETERS

No. 2 : deepest anchor 10 m

installed 28 m behind the face

installed on 09 / 10 / 85

last reading 24 / 11 / 86, 80 m behind the face

overall dilation = 7 mm

stope closure = 325 mm

This extensometer shows very little overall movement between the collar and ten metre anchor but within the length of the hole there was considerable differential movement. Between 2 m and 10 m there was substantial closing of beds (50 mm) most of which took place between 5 m and 8 m. This was matched by opening of 43 mm between the collar and the 2 m anchor.

No.3 : deepest anchor 16,5 m

installed 21 m behind the face

installed on 09 / 10 / 85

last reading 15 / 10 / 86, 75 m behind the face

overall dilation = 375 mm

stope closure = 500 mm

Very little opening between 10,5 m and 16 m was apparent in this extensometer. However, between 10,5 m and 3 m almost 300 mm of extension occurred, nearly half of which took place during the first 10 metres of face advance. There was little opening apparent between 5,5 m and the collar of the hole.

No.4 : deepest anchor 13 m

installed 21 m behind the face

installed on 09 / 10 / 85

last reading 15 / 10 / 86, 75 m behind the face

overall dilation = 350 mm

stope closure = 874 mm

A total of 350 mm opening was recorded by this extensometer, almost half taking place between 7 m and 10 m (170 mm). Opening was recorded between all the anchors, from 100 mm between 13 m and 10 m to 20 mm between 4 m and the collar. The total closure for the gully at this extensometer was substantially more than twice the observed extension in the hole.

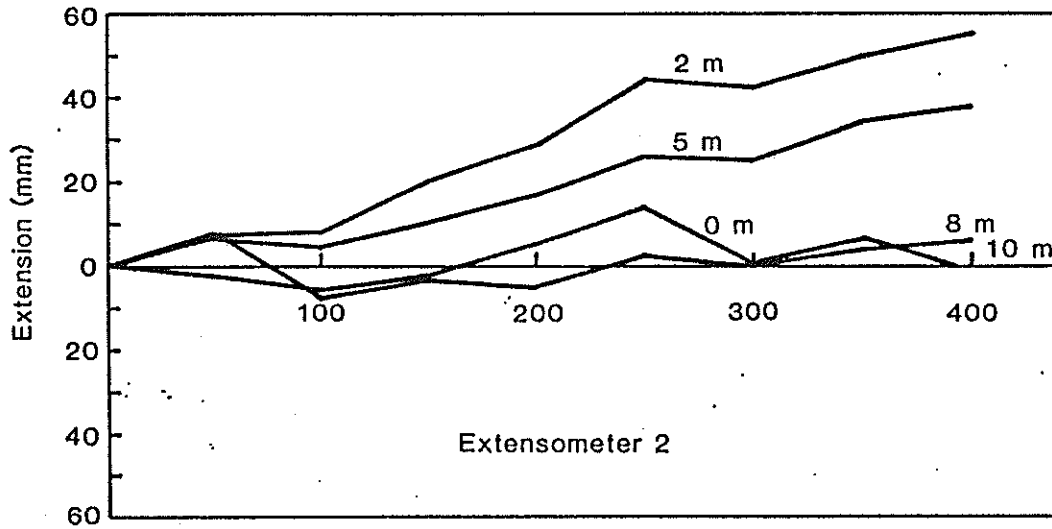

Figure V.1 EXTENSOMETER NUMBER 2, DAYS

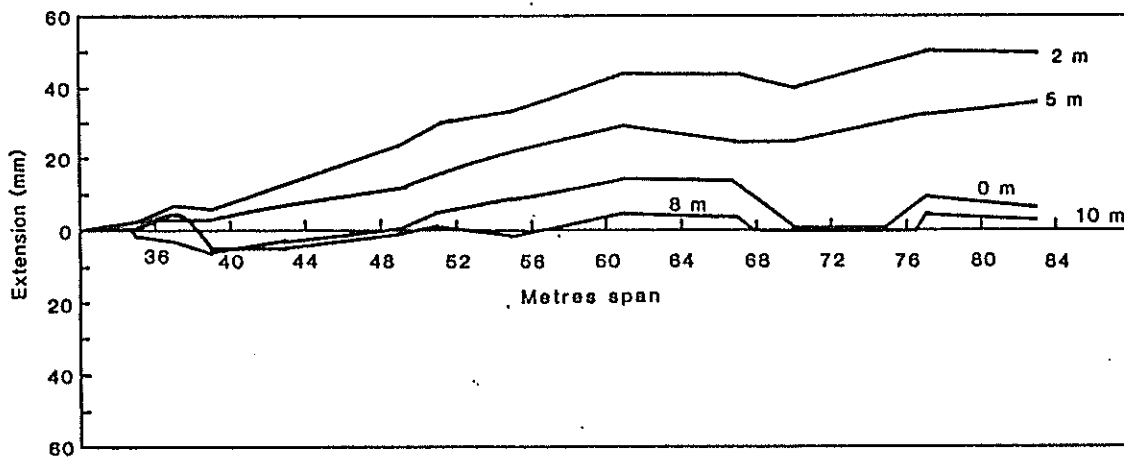

Figure V.2 EXTENSOMETER NUMBER 2, METRES FROM FACE

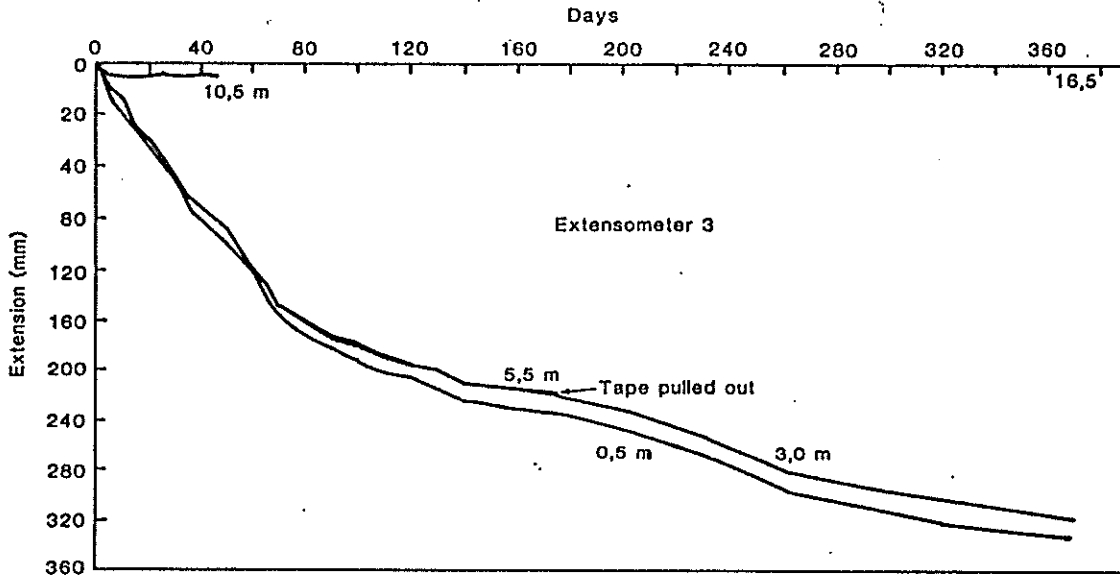

Figure V.3 EXTENSOMETER NUMBER 3, DAYS

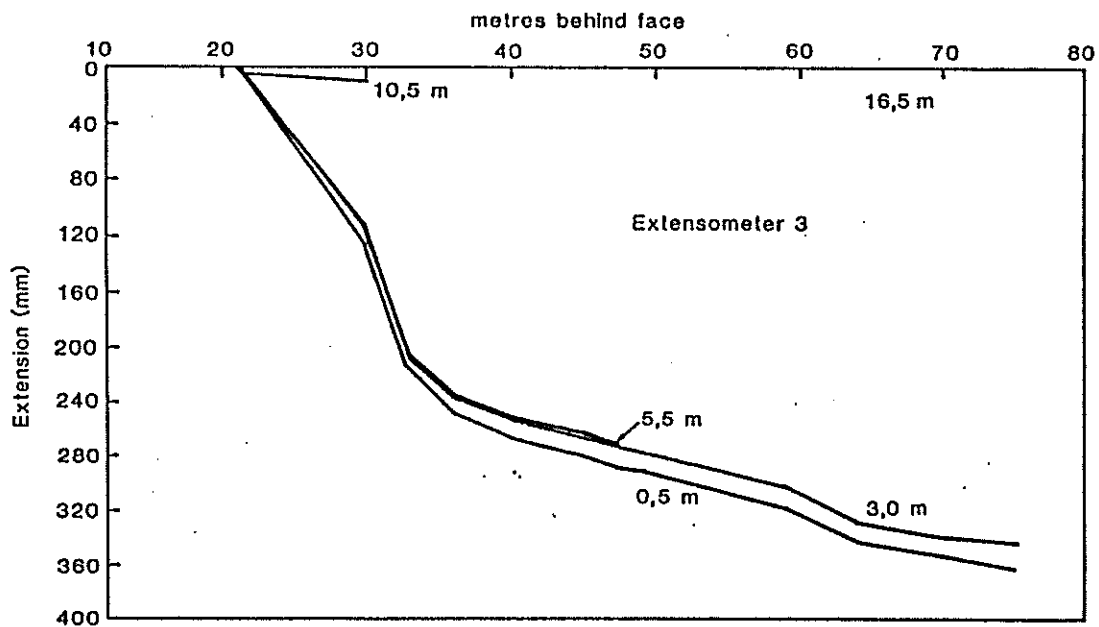

Figure V.4 EXTENSOMETER NUMBER 3, METRES FROM FACE

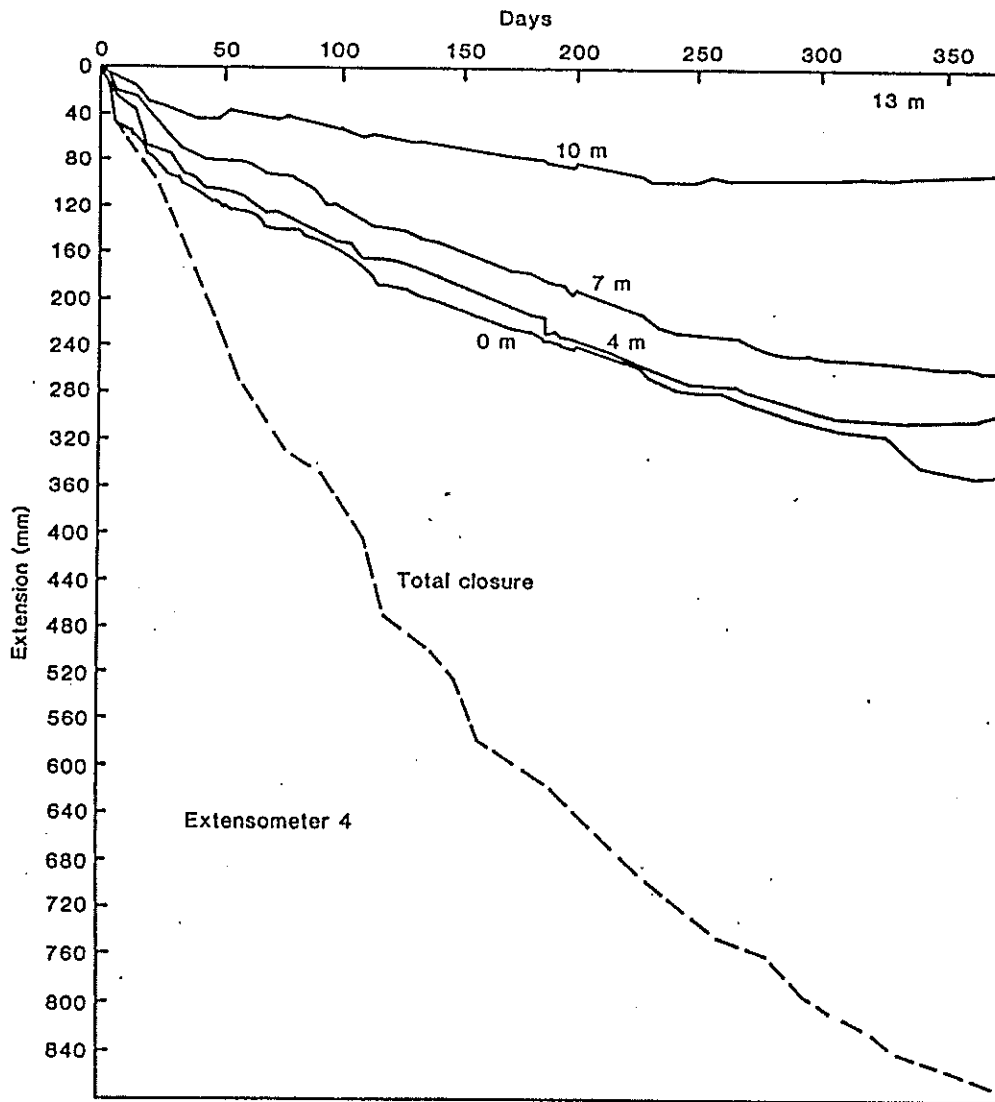

Figure V.5 EXTENSOMETER NUMBER 4, DAYS

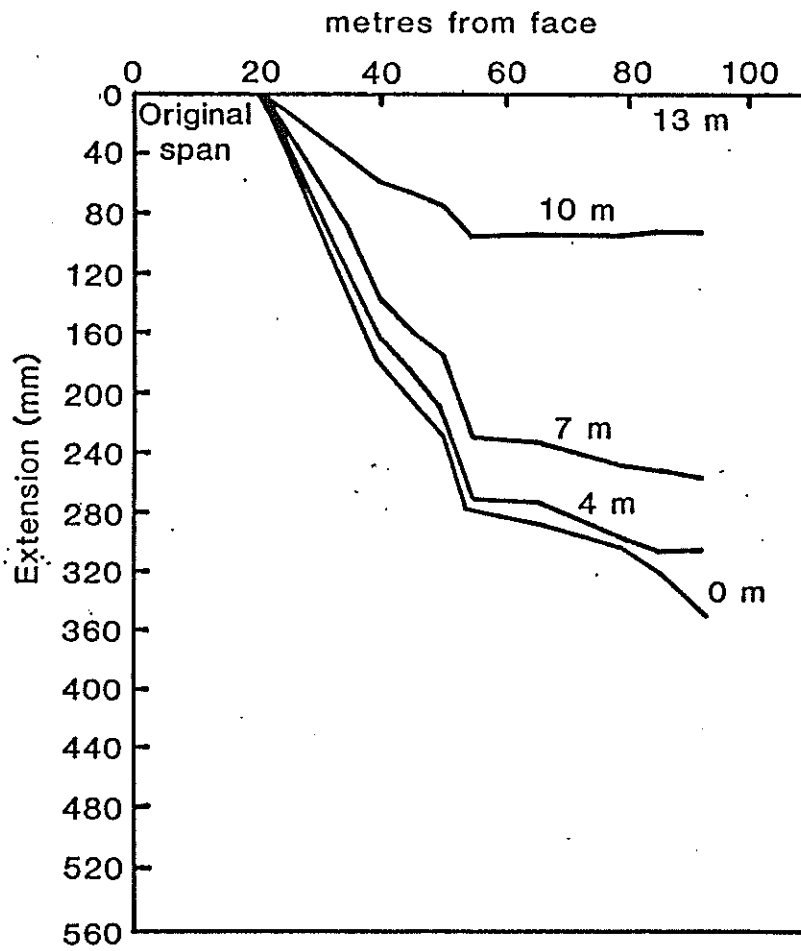

Figure V.6 EXTENSOMETER NUMBER 4, METRES FROM FACE

V.2 NUMBER 10 STRIKE GULLY EXTENSOMETERS

No.1 : deepest anchor 8,7 m

installed 1 m behind the face

installed on 09 / 10 / 85

last reading 25 / 11 / 86, 48 m behind the face.

overall dilation = 33 mm

stope closure = 725 mm

This extensometer shows a large initial dilation (28 mm) between anchors at 8,7 m and 4,5 m and small dilation (2 mm to 5 mm), apparently irreversible, between the lower anchors, indicating that the extensometer was cut off after approximately 1 m of face advance.

No.1a : deepest anchor 20 m

installed 2 m behind the face

installed on 18 / 11 / 85

last reading 01 / 11 / 86, 45 m behind the face

overall dilation = 106 mm

stope closure = 725 mm

This extensometers shows an initial substantial opening between the 6 m and 16 m anchors and between the 2 m and 4 m anchors. The dilation stabilises after 12 m face advance, but eventually closing slightly towards the end of the mining. Initial closing is apparent between the 16 m and 12 m anchors and between the 2 m and 4 m anchors followed by substantial closing and slow steady closing respectively after 3 m face advance.

No.11 : deepest anchor 7,5 m

installed 10 m behind the face

installed on 14 / 05 / 86

last reading 20 / 09 / 86, 20,5 m behind the face

overall dilation = 8 mm

stope closure = 236 mm

Little movement was observed before the face had advanced 3 m when opening between the collar and the 3 m anchor started. This was accompanied by closure between the 3 m and 4,5 m anchors and between the 6 m and 7,5 m anchors with a slight opening between 4,5 m and 6 m.

No.12 : deepest anchor 9,5 m

installed 10 m behind the face

installed on 14 / 05 / 86

last reading 20 / 09 / 86, 20,5 m behind the face

overall dilation = 0 mm

stope closure = 236 mm

After 2 metres of face advance 5 mm opening occurred between 3 m and 4,5 m with no overall extension of the hole, only a corresponding closing between 4,5 m and 7 m. Between 3 m and 7 m there was opening of up to 15 mm most of which was associated with closing of similar amounts between 7 m and 9 m. Overall there was very little extension of the hole between the collar and 9 m anchor.

No.13 : deepest anchor 10 m

installed 0 m behind the face

installed on 29 / 07 / 86

last reading 06 / 11 / 86, 20 m behind the face

overall dilation = 82 mm

stope closure = 200 mm

Between the collar and the 4 m anchor there was substantial opening of 45 mm up to 7,5 m behind the face. After that little further movement occurred. Similarly between 4 m and 6 m and between 6 m and 8 m, 12 mm and 35 mm opening respectively occurred, apparently irreversibly. Between 8 m and 10 m, however, 15 mm of closure was observed, also apparently irreversibly.

No.14 : deepest anchor 18 m

installed 0 m behind the face

installed on 29 / 07 / 86

last reading 06 / 11 / 86, 20 m behind the face

overall dilation = 20 mm

stope closure = 200 mm

Overall this hole closed up 20 mm while it was being measured, movement only starting after 5 m face advance. Most of the anchors closed up varying amounts between 5 mm and 15 mm, the most occurring between the 14 m and 18 m anchors. The only opening occurred between 8,5 m and 14 m.

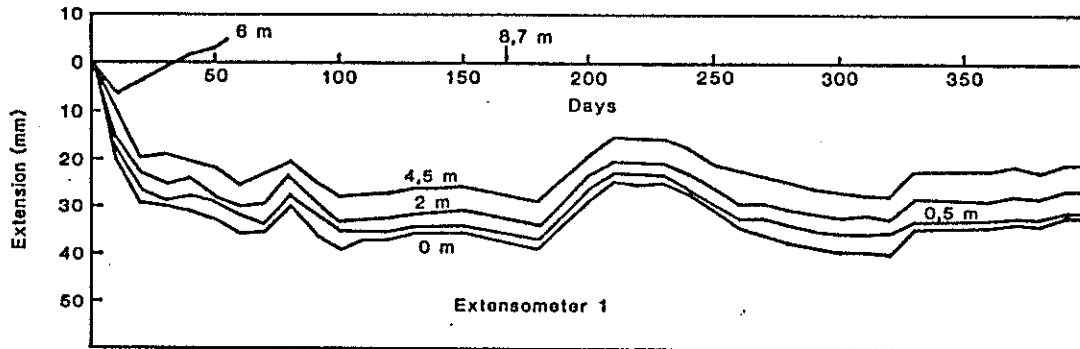

Figure V.7 EXTENSOMETER NUMBER 1, DAYS

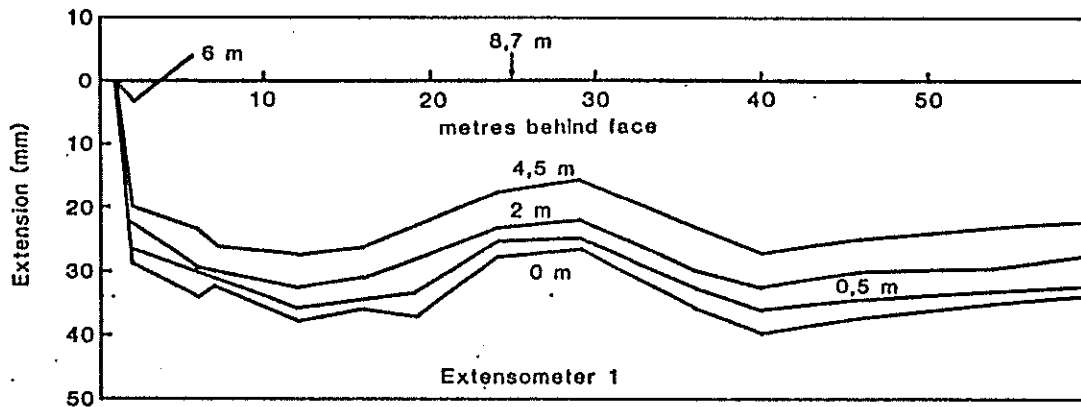

Figure V.8 EXTENSOMETER NUMBER 1, METRES FROM FACE

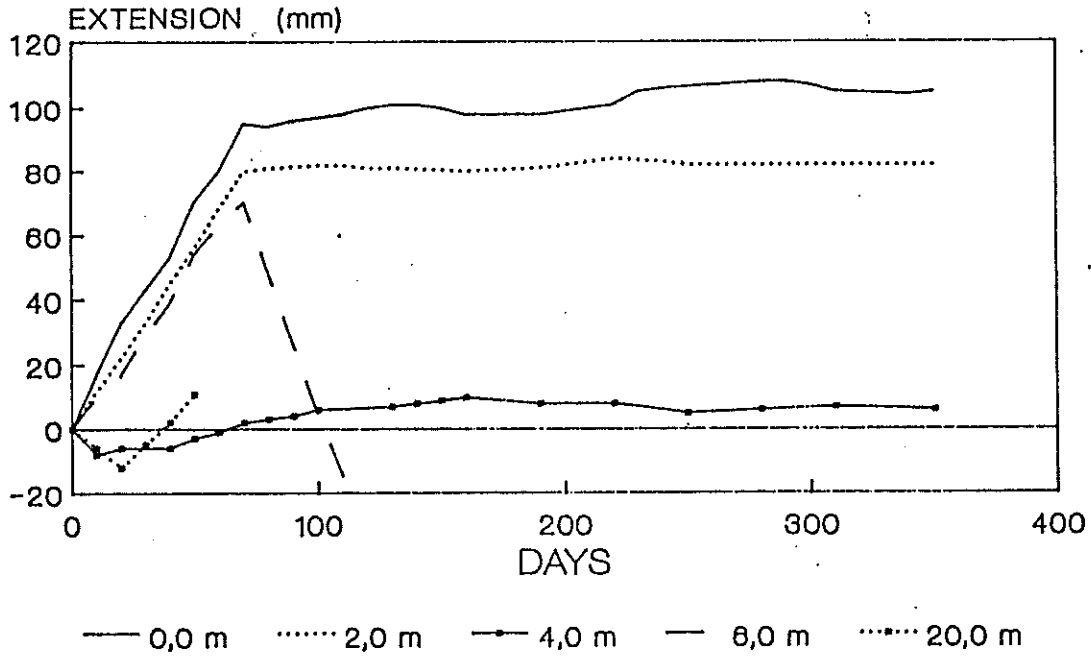

Figure V.9 EXTENSOMETER NUMBER 1A, DAYS

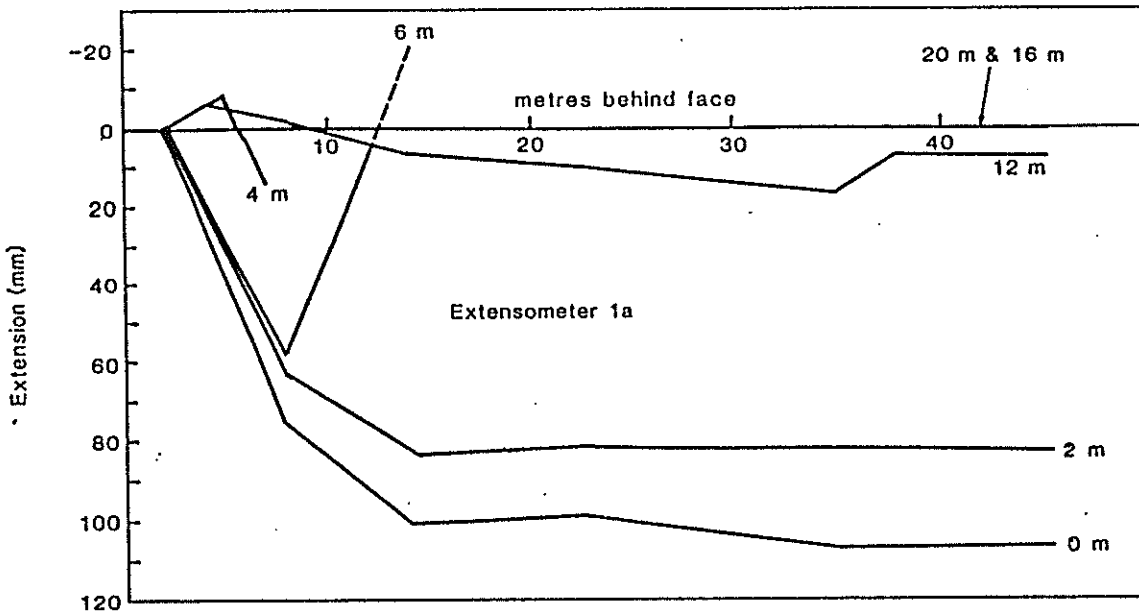

Figure V.10 EXTENSOMETER NUMBER 1A, METRES FROM FACE

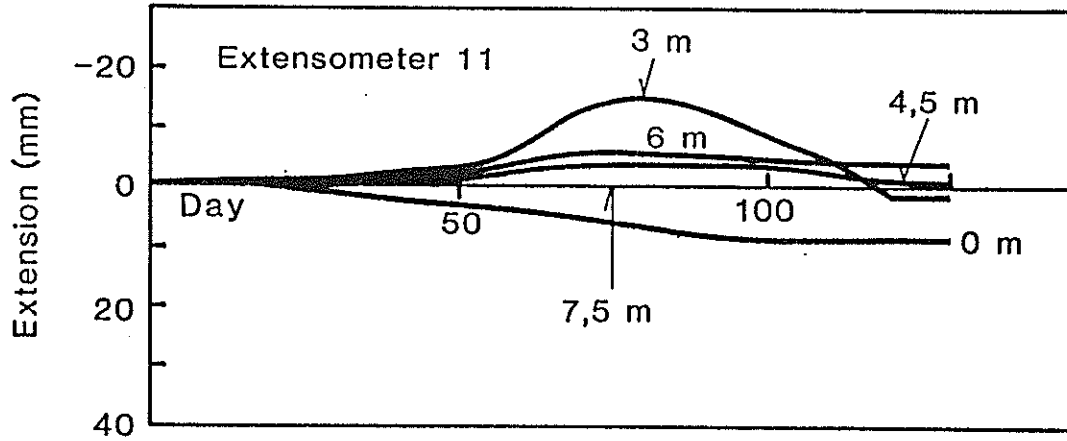

Figure V.11 EXTENSOMETER NUMBER 11, DAYS

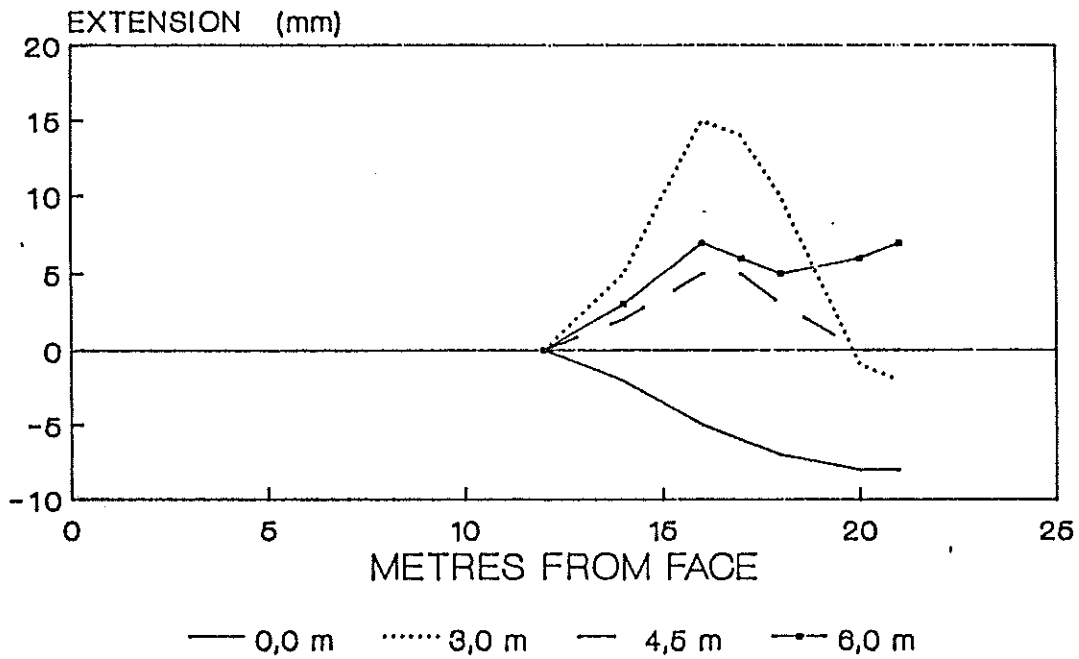

Figure V.12 EXTENSOMETER NUMBER 11, METRES FROM FACE

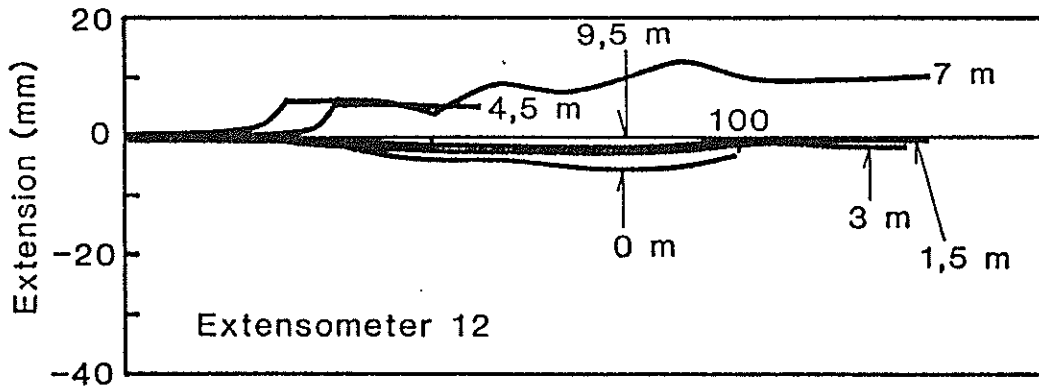

Figure V.13 EXTENSOMETER NUMBER 12, DAYS

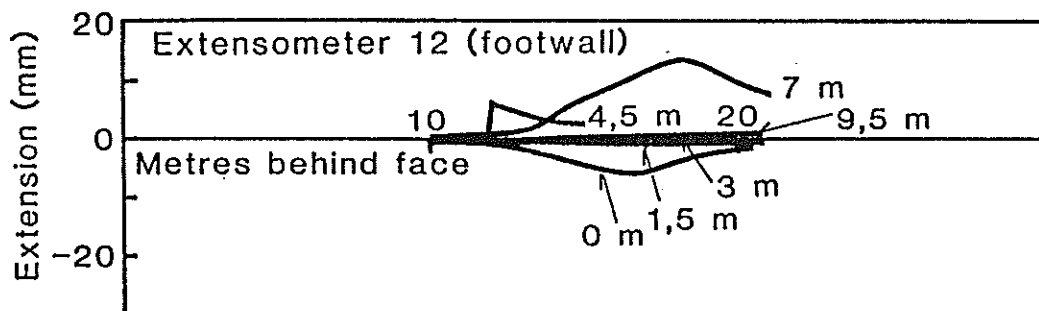

Figure V.14 EXTENSOMETER NUMBER 12, METRES FROM FACE

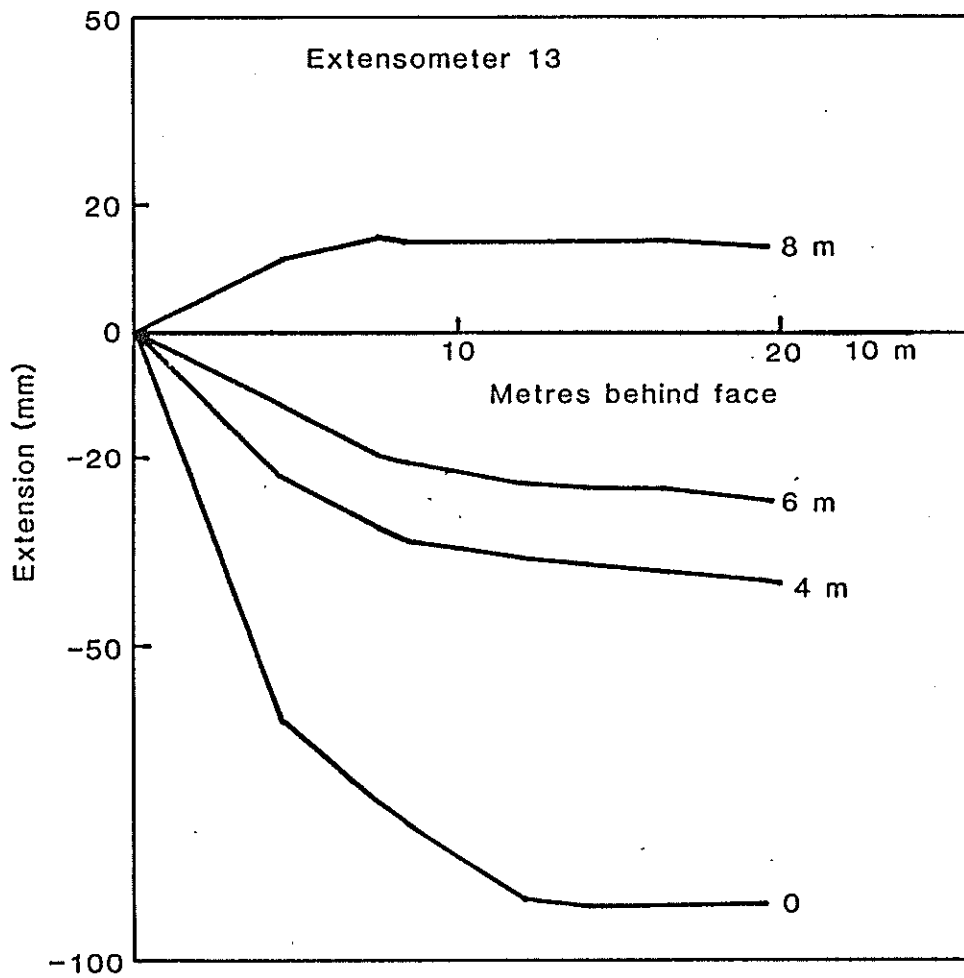

Figure V.15 EXTENSOMETER NUMBER 13, DAYS

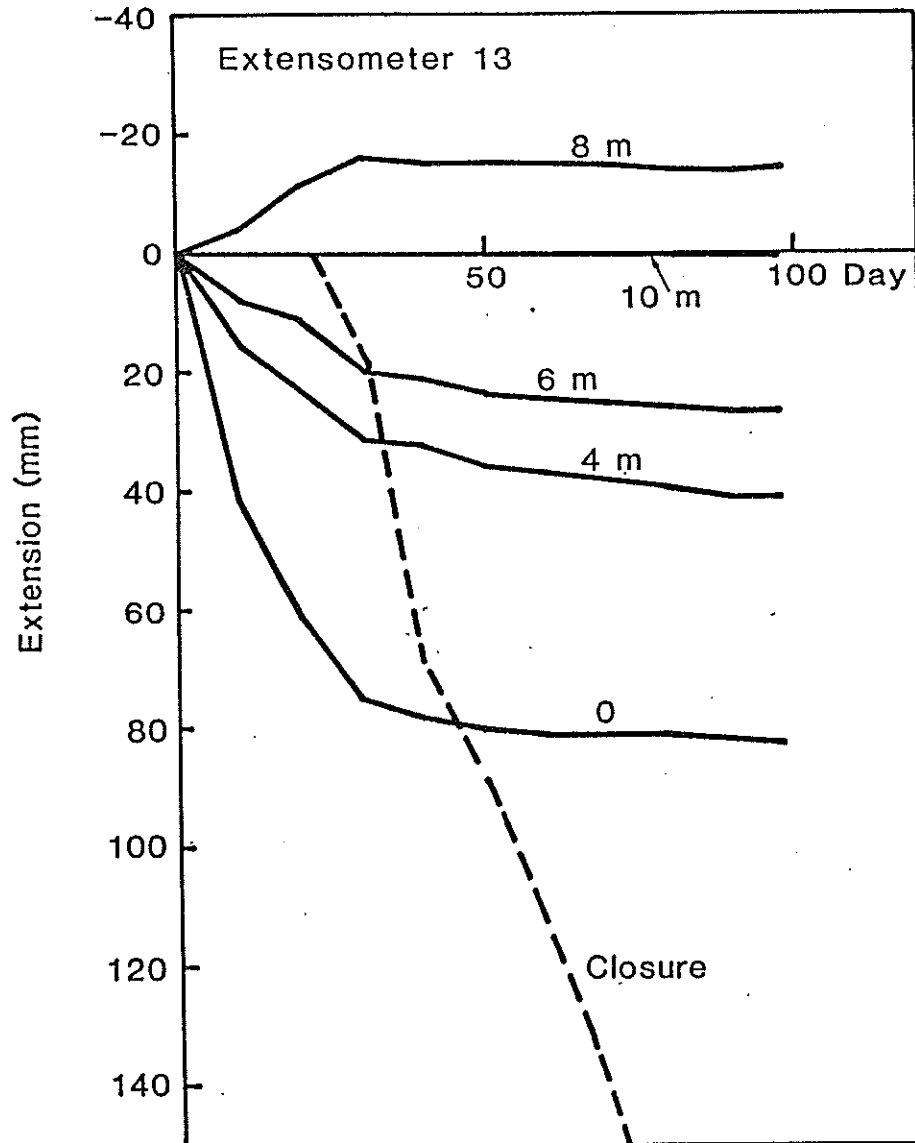

Figure V.16 EXTENSOMETER NUMBER 13, METRES FROM FACE

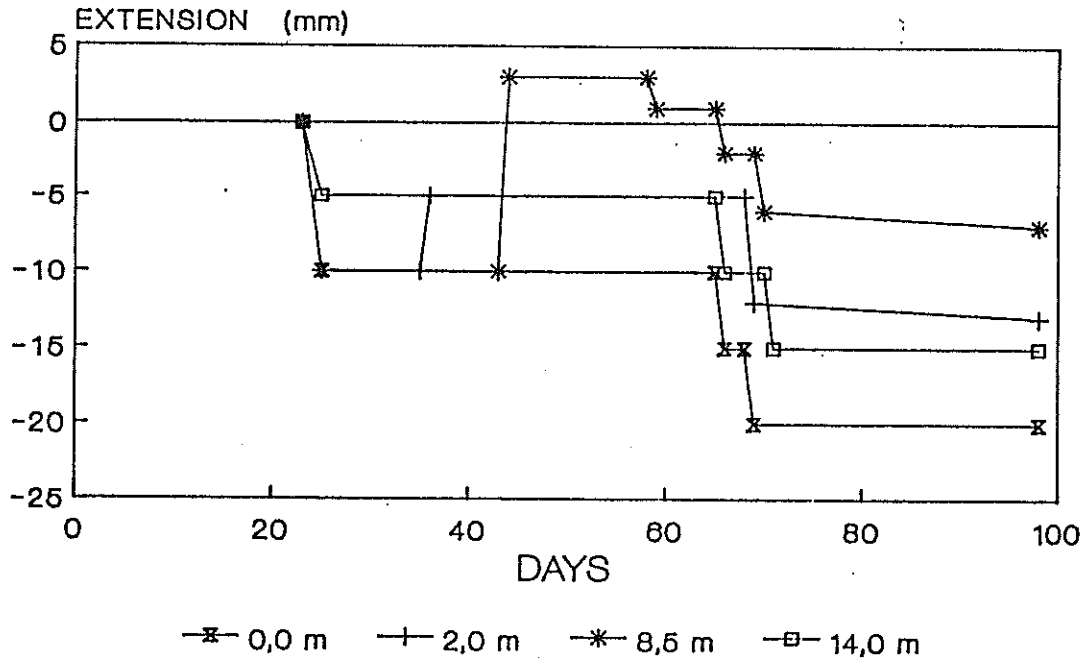

Figure V.17 EXTENSOMETER NUMBER 14, DAYS

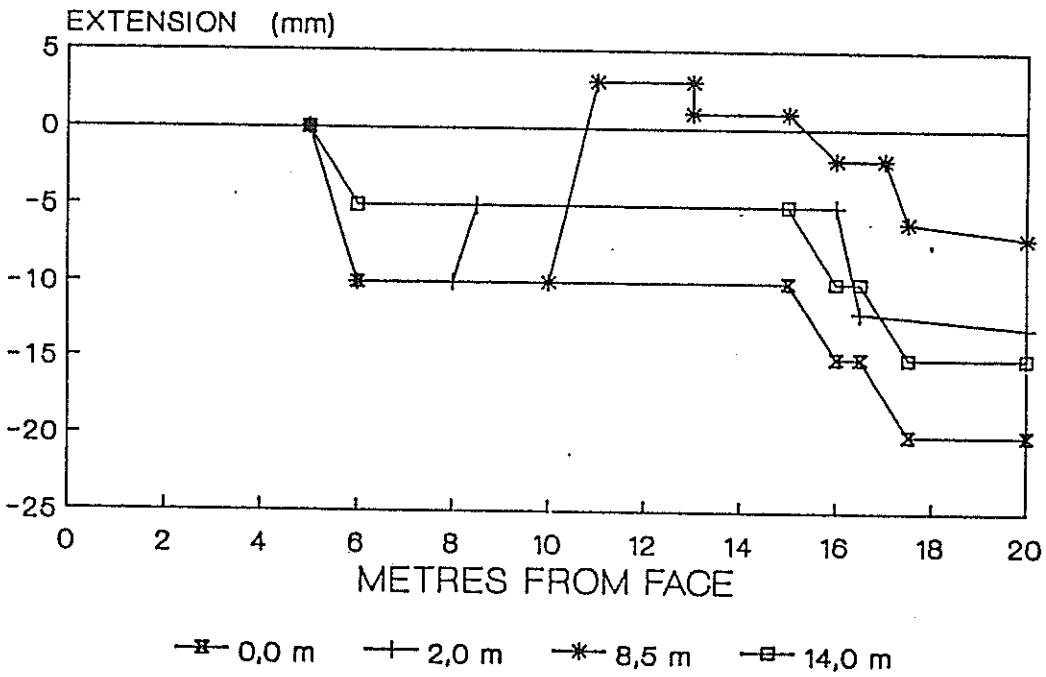

Figure V.18 EXTENSOMETER NUMBER 14, METRES FROM FACE

V.3 PANEL EXTENSOMETERS

No.5 : deepest anchor 10 m

installed 1 m behind the face

installed on 24 / 12 / 85

last reading 12 / 02 / 86, 9 m behind the face

overall dilation = 36 mm

stope closure = 210 mm

Significant movement only occurred after ten days as the face had been standing for some time before and after the installation of the extensometer. Substantial opening occurred between the 8 m and 10 m anchors (17 mm) with a corresponding closing between 8 m and 5 m. Closing also occurred between the 5 m and 2,5 m anchors, but very little movement was recorded below 2,5 m.

No.6 : deepest anchor 10 m

installed 1 m behind the face

installed on 08 / 01 / 86

last reading 04 / 04 / 86, 10 m behind the face

overall dilation = 15 mm

stope closure = 220 mm

Overall there was only 16 mm of extension in the hole from the collar to 10 m. Within that 10 metres, though, there was substantial differential movement. Between the 7 m and 10 m anchors opening of 37 mm was recorded, with closure of nearly 20 mm between the 4 m and 7 m anchors and 40 mm between the 4 m and 2 m anchors. Between the 2 m and 0,2 m anchors there was almost 35 mm of opening. Most of the movement took place in the first 2 metres of face advance which took almost 18 days.

No.7 : deepest anchor 10 m

installed 1 m behind the face

installed on 07 / 04 / 86

last reading 02 / 05 / 86, 10 m behind the face

overall dilation = 150 mm

stope closure = 270 mm

Little movement was recorded before 2 metres face advance except between the 10 m and 8 m anchors. Here a progressively increasing opening occurred up to 48 mm before the "cave." After 2 metres opening was recorded between the 4 m and 2 m anchors and between the 2 m anchor and the collar. The latter had increased to 62 mm before the extensometer became inaccessible. The only other significant movement occurred between the 6 m and 4,5 m anchors after 4 m of face advance.

No.8 : deepest anchor 10 m

Installed 1 m behind the face

installed on 15 / 04 / 86

last reading 06 / 05 / 86, 5 m behind the face

overall dilation = 76 mm

stope closure = 205 mm

No movement was apparent between 10 m and 8 m for this extensometer. Between 8 m and 6 m 10 mm of opening occurred. The major movements took place between 6 m and 4 m, with 32 mm of opening between 4 m and 5 m and 21 mm between 5 m and 6 m. The two lowest anchors, 1 m and 2 m, showed significant closure for the first metre of face advance, opening thereafter.

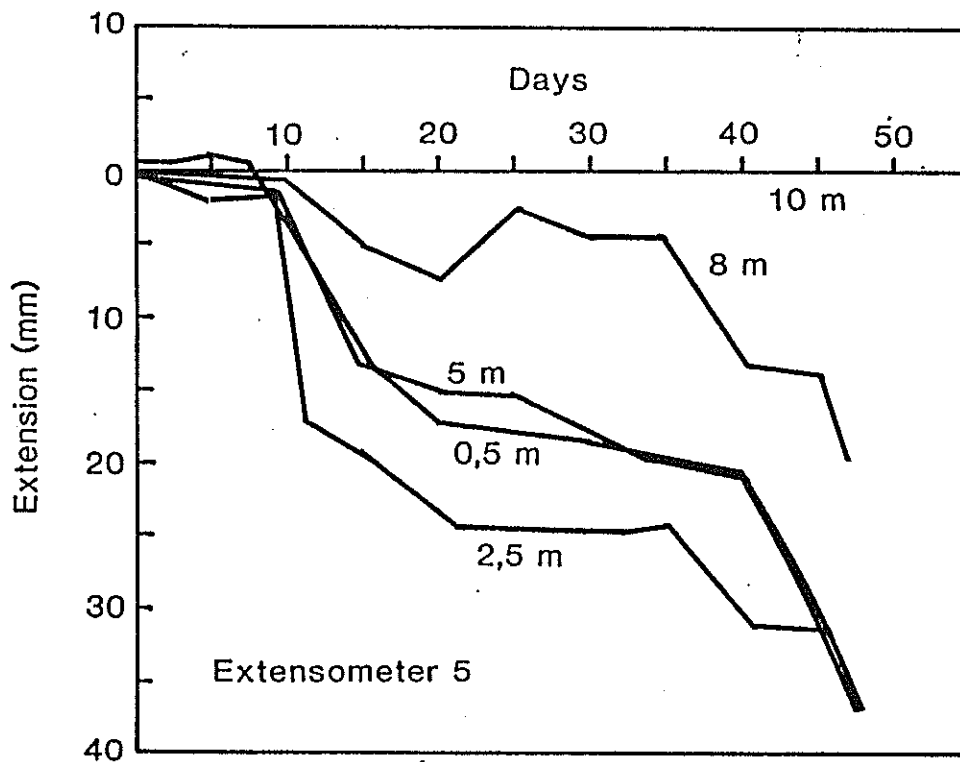

Figure V.19 EXTENSOMETER NUMBER 5, DAYS

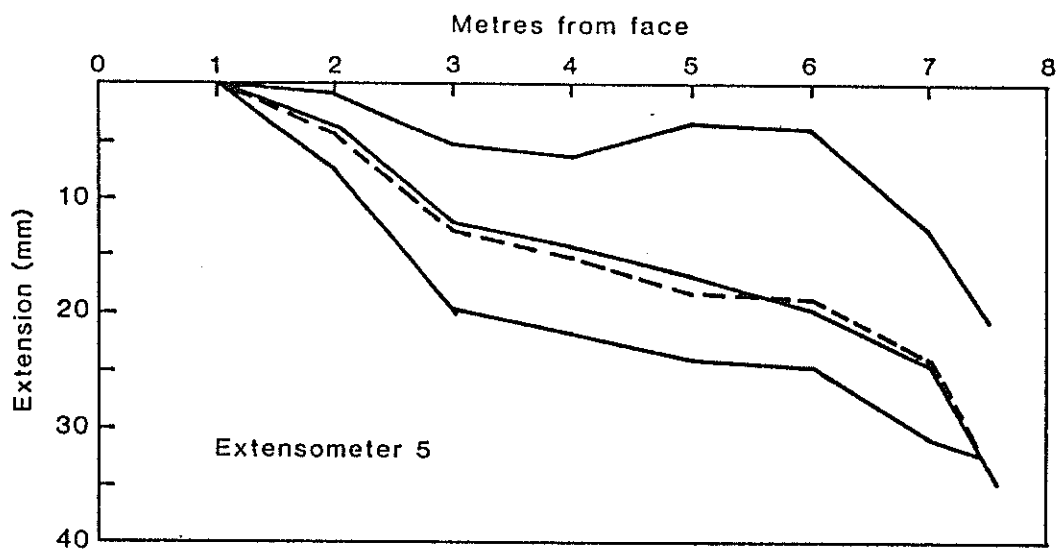

Figure V.20 EXTENSOMETER NUMBER 5, METRES FROM FACE

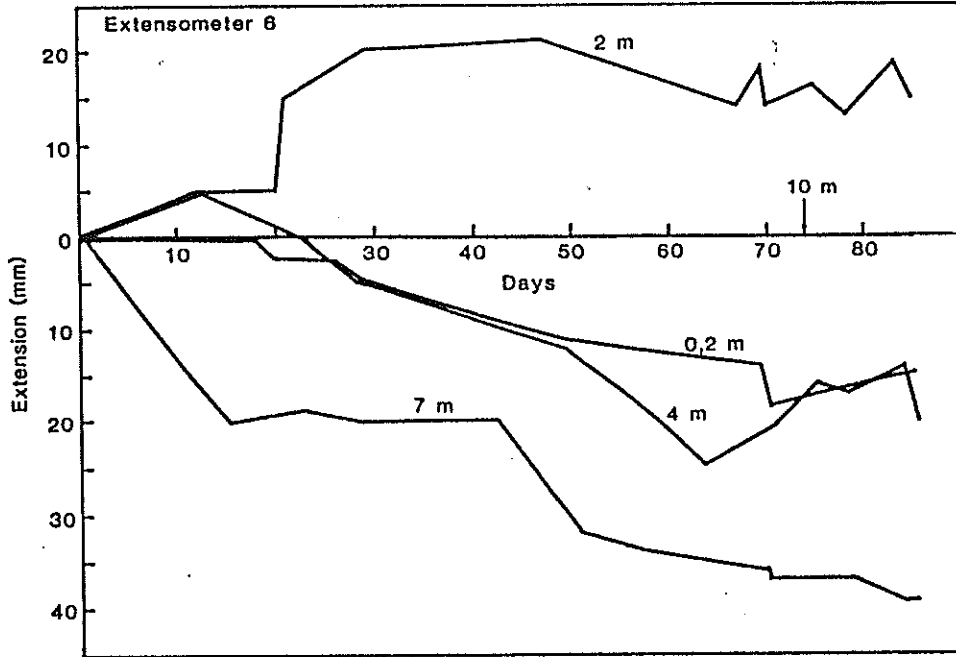

Figure V.21 EXTENSOMETER NUMBER 6, DAYS

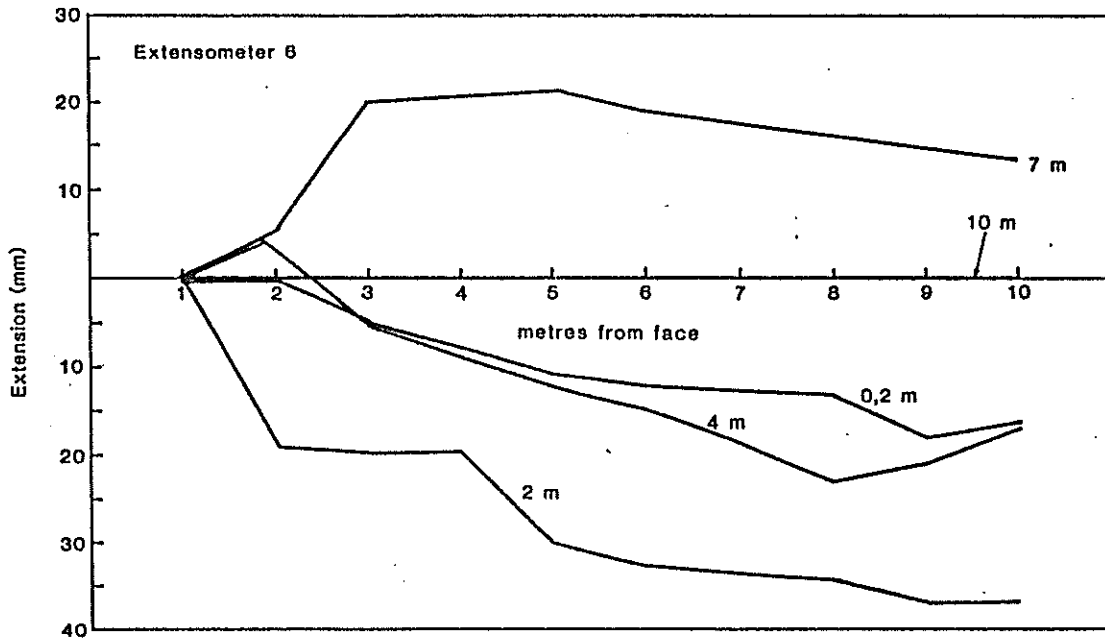

Figure V.22 EXTENSOMETER NUMBER 6, METRES FROM FACE

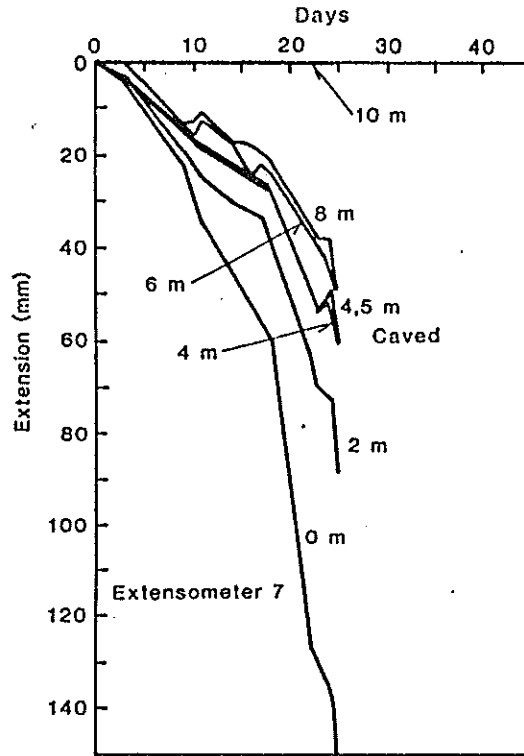

Figure V.24 EXTENSOMETER NUMBER 7, METRES FROM FACE

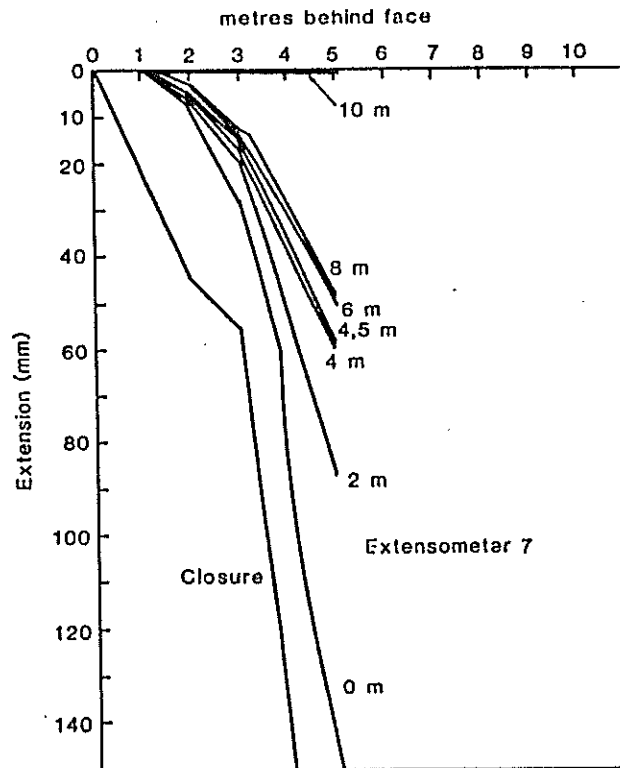

Figure V.23 EXTENSOMETER NUMBER 7, DAYS

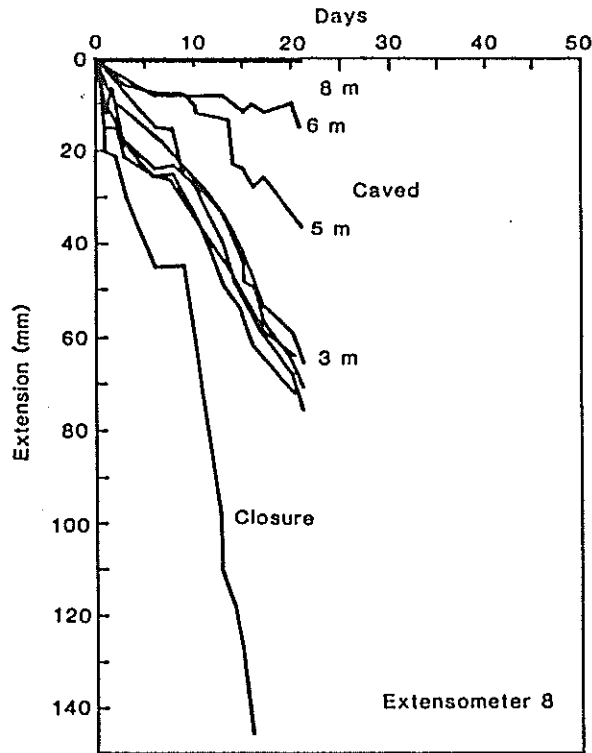

Figure V.25 EXTENSOMETER NUMBER 8, DAYS

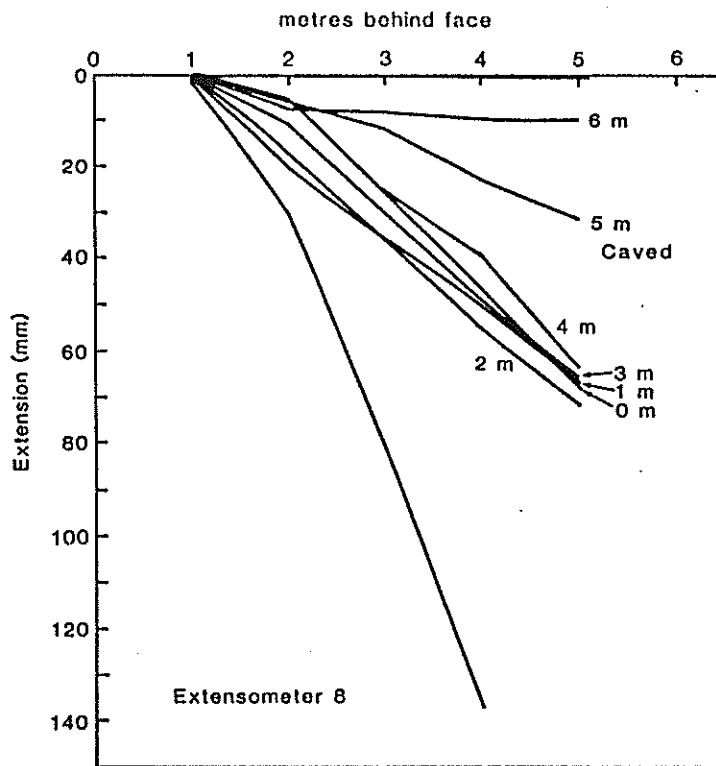

Figure V.26 EXTENSOMETER NUMBER 8, METRES FROM FACE

V.4 RAISE EXTENSOMETERS

No.9 : deepest anchor 14 m

installed 12 m ahead of the face

installed on 29 / 04 / 86

last reading 15 / 10 / 86, 21 m behind the face

overall dilation = 369 mm

stope closure = N/A

Two sets of anchors were installed in this hole, the original set from 8 m to 14 m (4,5 m into the hangingwall to 0,5 m into the footwall) and a second set from 1,5 m to 7 m (11 m and 5,5 m into the hangingwall) installed after it became apparent that the number 10 extensometer had been cut off.

Initially in the lower portion of the hole little movement was recorded between 3,5 m and 1,5 m above the reef, with substantial amounts of movement below 1,5 m. As the face approached the extensometer the 12 m and 13 m anchors moved away from the 11 m anchor while the 14 m anchor maintained the same spacing. Nearer the face the 12 m and 13 m anchors began to move apart which they continued to do for the life of the extensometer. The 14 m anchor started to move away from the 11 m anchor then, as the face passed the extensometer, it started to move closer. It should be noted, however, that the anchors below 12 m were cut off as the face passed under the extensometer, and that the anchors in the immediate hangingwall may have been damaged by the blasting. Above 1,5 m into the hangingwall most of the movement was between the 8 m anchor and the collar of the hole. Movement was recorded between 2,5 m and 3,5 m above the reef, with the 9 m anchor moving away from the 10 m anchor as the face approached and moving back towards it as the face retreated. The upper anchors, above 5 m into the hangingwall, all moved away from the 11 m anchor until the face was 16 m ahead of the extensometer when they were all moving together suggesting the hole had been cut off. Opening occurred between the 4,5 m and 6 m anchors and between the 1,5 m anchor and the collar of the hole.

No.10 : deepest anchor 10 m

installed 15 m ahead of the face

installed on 15 / 04 / 86

last reading 03 / 06 / 86

overall dilation = 104 mm

stope closure = N/A

The results from this extensometer show all the anchors moving together away from the collar, meaning that the hole had sheared badly trapping the extensometer wires.

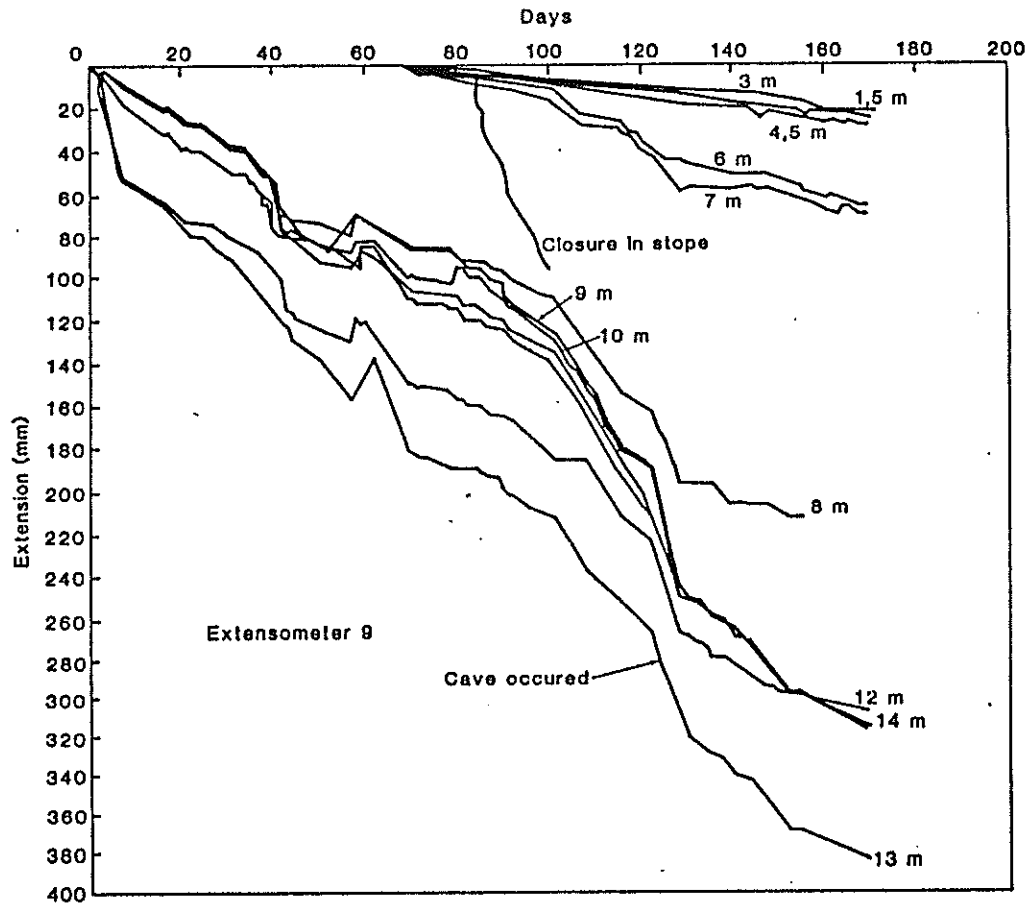

Figure V.27 EXTENSOMETER NUMBER 9, DAYS

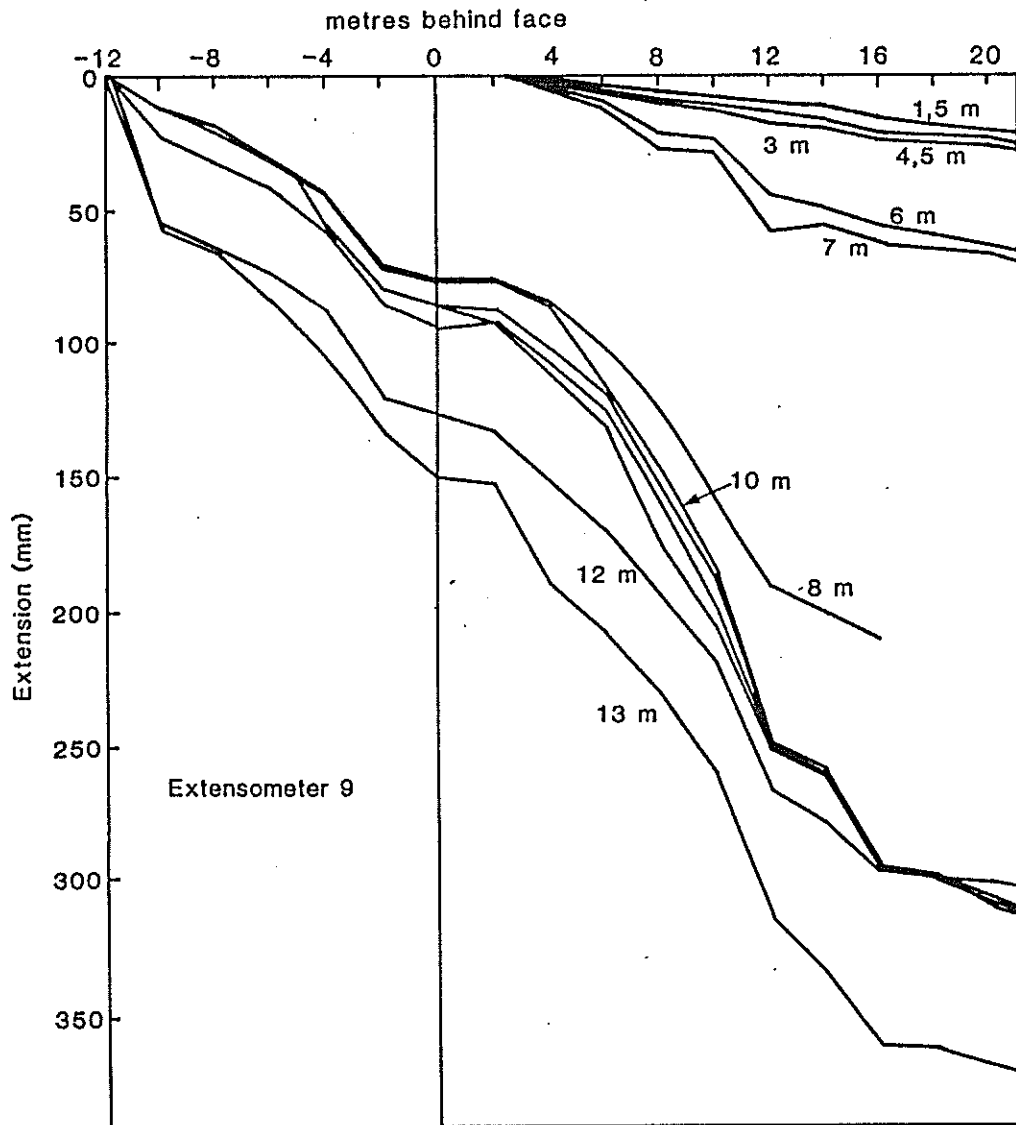

Figure V.28 EXTENSOMETER NUMBER 9, METRES FROM FACE

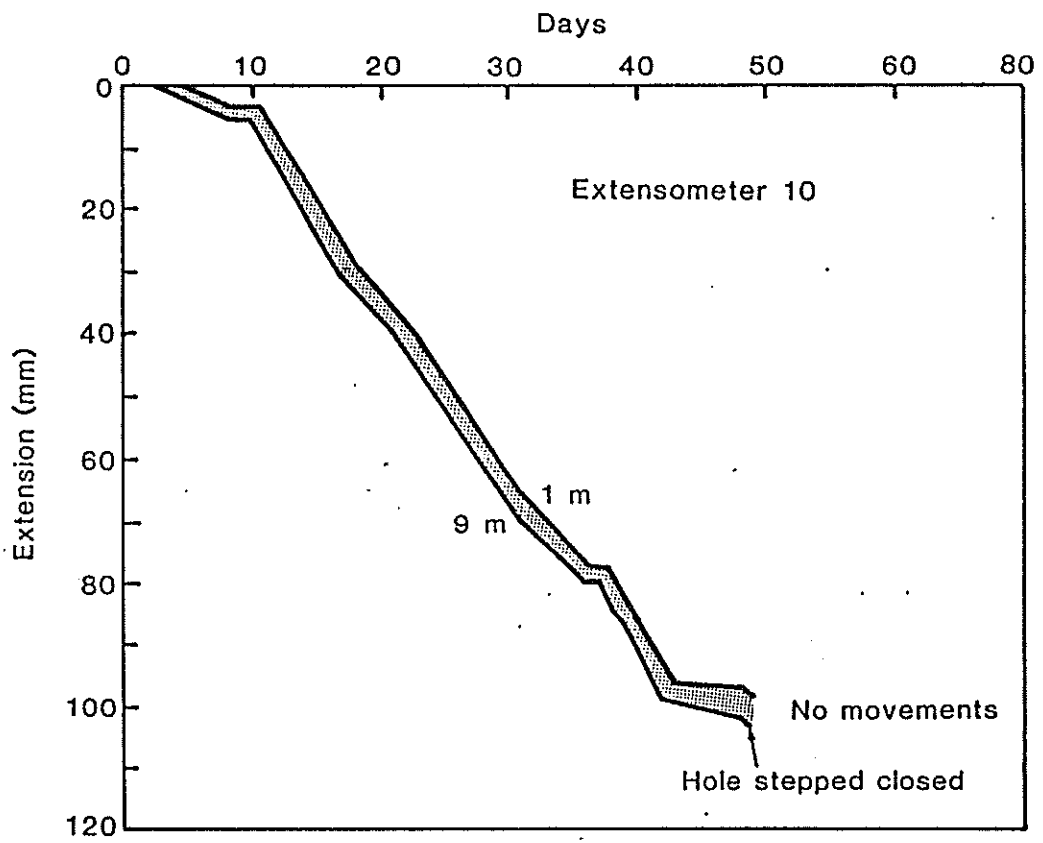

Figure V.29 EXTENSOMETER NUMBER 10, DAYS

APPENDIX VI

CLOSURE RESULTS

VI.1 CLOSURE

The closure not accounted for by the extensometers can be calculated using the following method:

Assumption - half the closure is contributed by the footwall and half by the hangingwall

(This is not necessarily so, at this site the footwall in the stope appeared to deform more than the hangingwall).

therefore - divide the closure by two and deduct the total deformation measured in the extensometer to obtain the deformation not measured by the extensometer (Figure VI.1).

VI.2 CLOSURE RATE

The analysis of the stope closure is considered in terms of both closure per day and as closure per metre of face advanced.

The closure rate in the working area decreased with increasing strike stope spans and this is illustrated in Figures VI.2 and VI.3.

However, the change in the remnant width is not inversely proportional to the span as the remnant was also being mined from the adjacent raise connection. Closure rates of 16 mm / day were measured initially when the stoping span was 86 m and the width of the remnant was 36 m for the 10 N panel and 26 m for the 9 N panel. These closure rates decreased to 6 - 8 mm / day when the stoping span reached 120 m to 128 m. The remnant spans decreased to 22 m for the 10 N panel and to 6 m for the 9 N panel respectively. This is contrary to that which would be expected from an elastic analysis of this mining geometry. Such an analysis shows that the stope closure rate in the face area increases with increasing mining span.

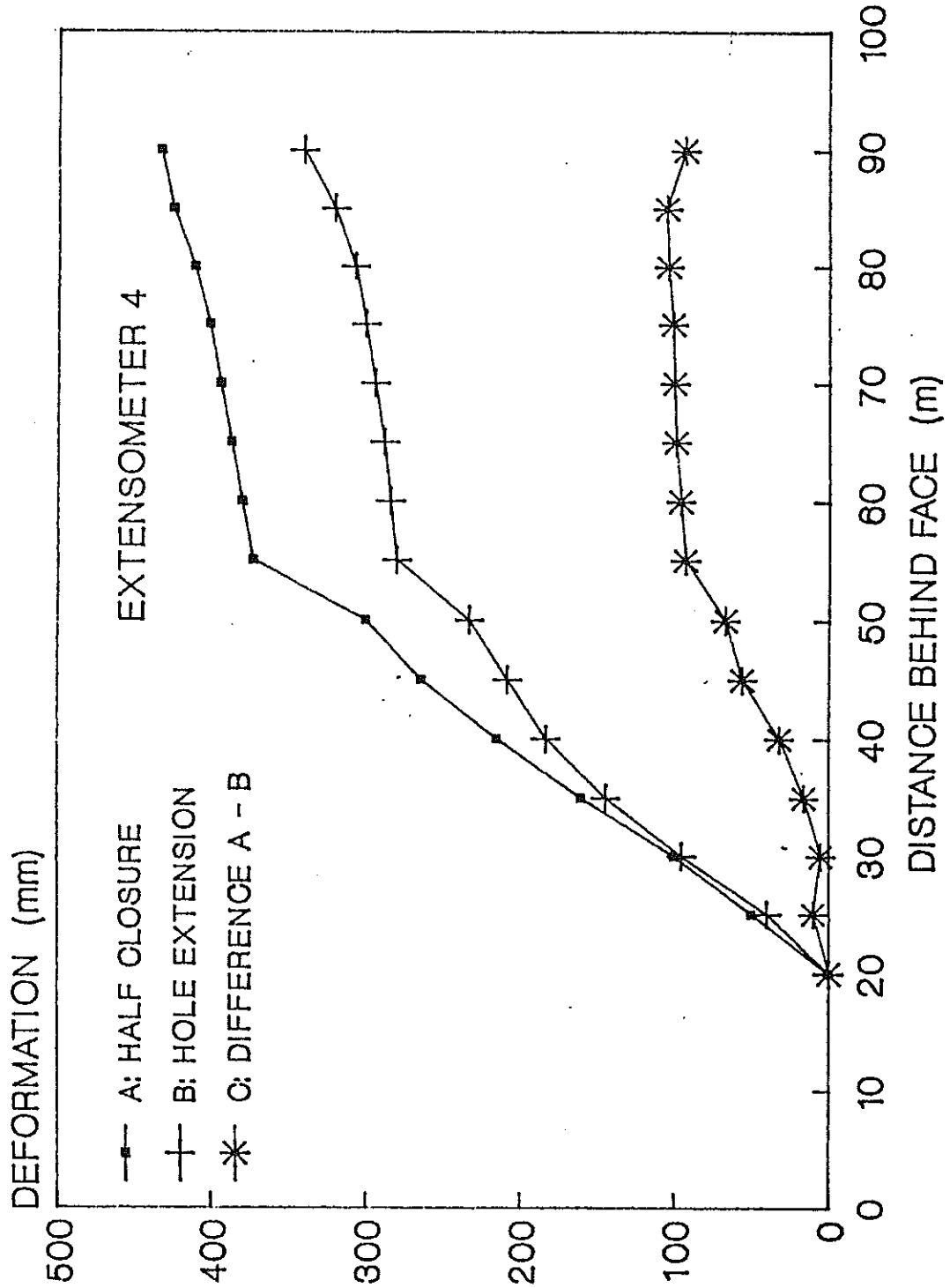

Figure VI.1 HANGINGWALL DILATION NOT MEASURED BY THE EXTENSOMETER

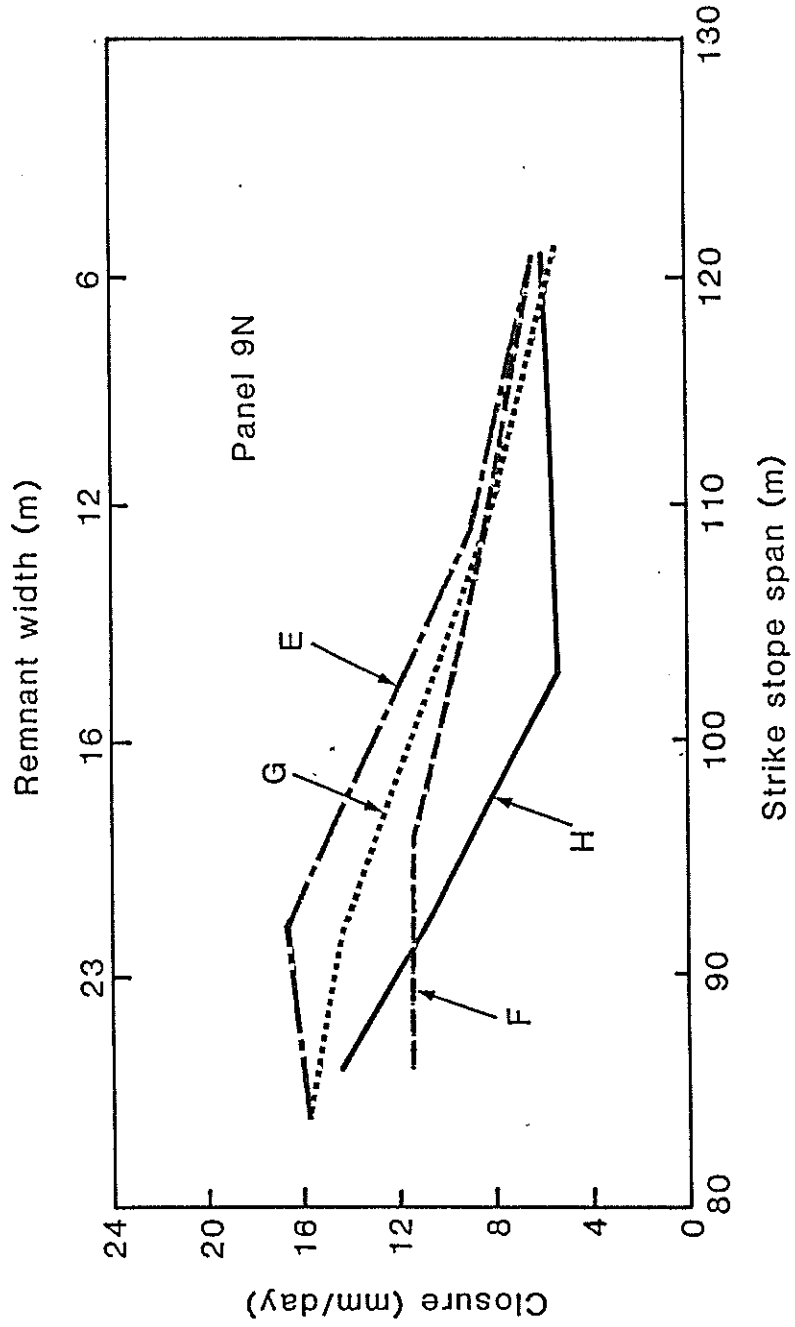

Figure VI.2 CHANGE IN CLOSURE RATES IN PANEL 9 NORTH

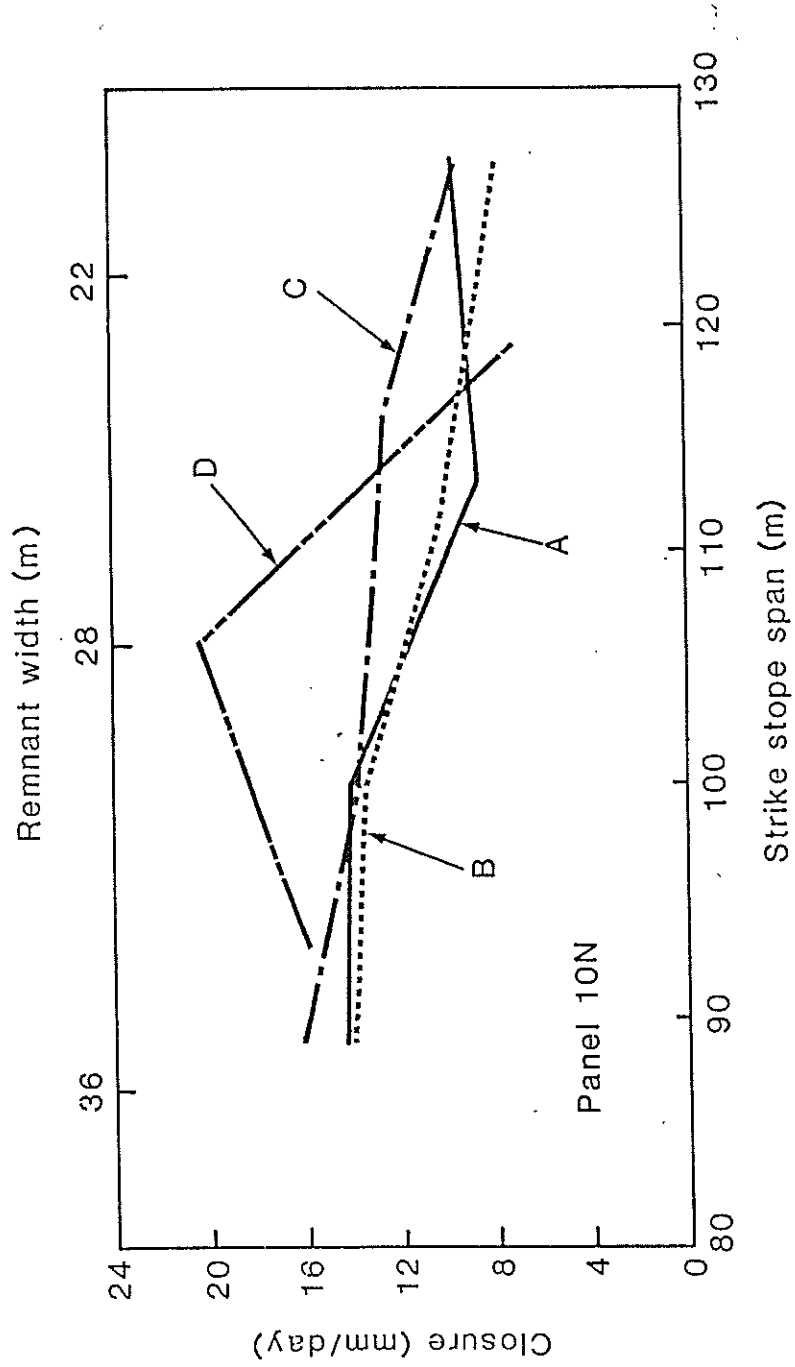

Figure VI.3 CHANGE IN CLOSURE RATES IN PANEL 10 NORTH

VI.3 TIME DEPENDENCE

The 9 N panel was holed on the 8th of September and on this date the remnant on the 10 N panel was still nearly 10 m wide, Figure VI.3. The 10 N panel remnant was finally extracted on the 21st of October. The panel was, however, not completely holed and a 1,0 m wide pillar of reef was left unmined.

In the 9 N panel, blasting activity ceased on the 8th of September. From this date until the 15th of October a period of 37 days, the stope closure rate in the face of the 9 N panel remained at a constant 6 mm / day as can be seen in Figure VI.4. Between the 16th of October and the 21st of October, a period of 6 days the closure rate decreased to 3,3 - 3,0 mm / day after this the closure rate further gradually decreased with time.

The rate of stope closure in the 10 N panel was 5,0 mm/day after the cessation of blasting on the 21st of October. This closure rate persisted for 13 days and then declined as shown in Figure VI.4.

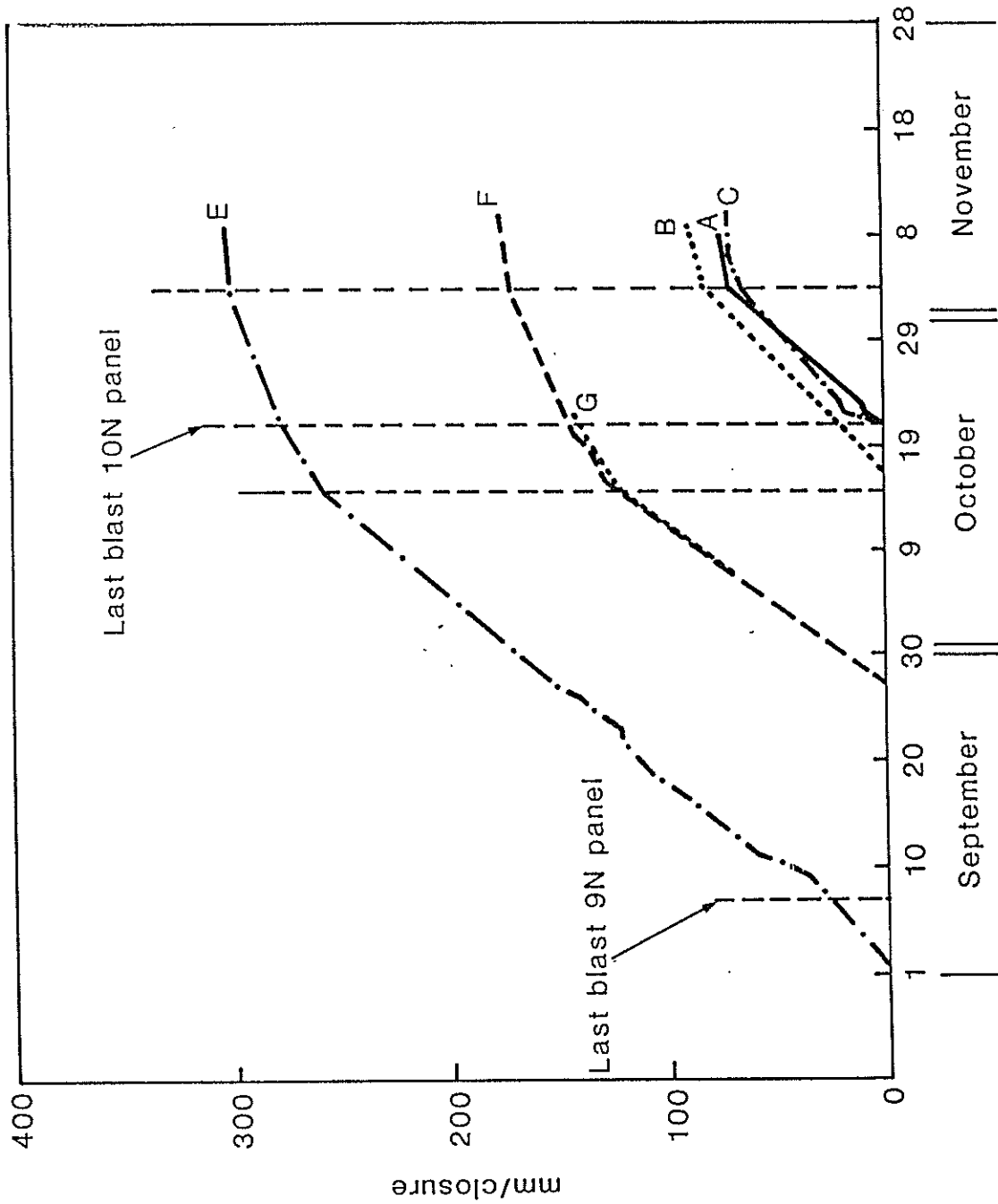

Figure VI.4 CHANGE IN CLOSURE RATE AFTER MINING STOPPED

APPENDIX VII

FRACTURE SURVEY RESULTS

VII.1 FRACTURES RELATED TO PREVIOUS MINING ACTIVITY

Before the mining of the 77/N/25 9 N and 10 N panels the 75/N/25 1 N panel and those panels above it had been advanced well ahead of the experimental panels. Well developed fracturing, parallel with the down-dip siding of the 1 N panel, was observed extending 8 m down-dip of the siding into the 10 N panel. While logging fractures in the back-areas of the 10 N panel anomalous fractures with strike 42° left of the siding face were observed as much as 16 m down dip from the siding. Several of these anomalous fractures were followed continuously to the gully side pack line.

VII.2 FRACTURE ORIENTATION

Before the 'cave' 38,5 % of fractures dipped toward the solid with an average dip of 80° as against 54 % after the 'cave' with an average dip of 75° . The 61,5 % of fractures dipping toward the mined out area before the 'cave' had an average dip of 73° , while after the 'cave' 46 % of fractures dipped toward the mined out area at an average dip of 76° . The proportion of upward-convergent adjacent fractures which could initiate falls decreased insignificantly from 48% to 45%. Likewise the mean angle of upward closure of adjacent fractures changed minimally from 27° to 29° .

No significant change in either the average forward or backward dip of the fractures before and after the 'cave' was apparent. What change there was represents a slightly shallower dip forward after the 'cave', which is contrary to previous observations made in 'caving' stopes.

A further aspect concerning the influence of fracture orientation on hangingwall stability was examined. The incidence of blocks bounded by upward convergent fractures and the magnitude of the angle of upward closure were calculated. Here too the difference between the proportion of these blocks before (48 %) and after (44,9 %) the cave is insignificant, as is the difference in the mean angle of closure before and after the cave (17 % and 18,5 % respectively).