

AN OVERVIEW OF EXPERIMENTAL MEASUREMENTS IN A GENERIC CAN- TYPE GAS TURBINE COMBUSTOR

Student: Ms. BC Meyers
Supervisor: Dr. GI Mahmood
Co-Supervisors: Mr. GC Snedden
Prof. JP Meyer



100
1908 - 2008



UNIVERSITEIT VAN PRETORIA
UNIVERSITY OF PRETORIA
YUNIBESITHI YA PRETORIA

Denkeleers • Leading Minds • Dikgopolo tša Dihalefi

OVERVIEW



- INTRODUCTION
- EXPERIMENTAL SETUP
- EXPERIMENTAL PROCEDURE
- EXPERIMENTAL RESULTS
- CONCLUSION
- ACKNOWLEDGEMENTS

INTRODUCTION



- **The purpose of the study was to:**
 - **Create a combustor test case → comparison to computational fluid dynamics (CFD).**
 - **The Particle Image Velocimetry (PIV) results → non-reacting isothermal runs to test the applicability/validity of the turbulence models used.**
 - **Thermocouple measurements at outlet plane → combustion run comparisons**
 - **The combustor measured has all the features found in a gas turbine combustor i.e. swirler, primary holes, secondary holes, dilution holes, cooling rings**



EXPERIMENTAL SETUP

- Test rig components:
 - 11 kW fan
 - Orifice plate with D and D/2 Pressure tapings
 - Can-type combustor liner
 - Exhaust to atmosphere

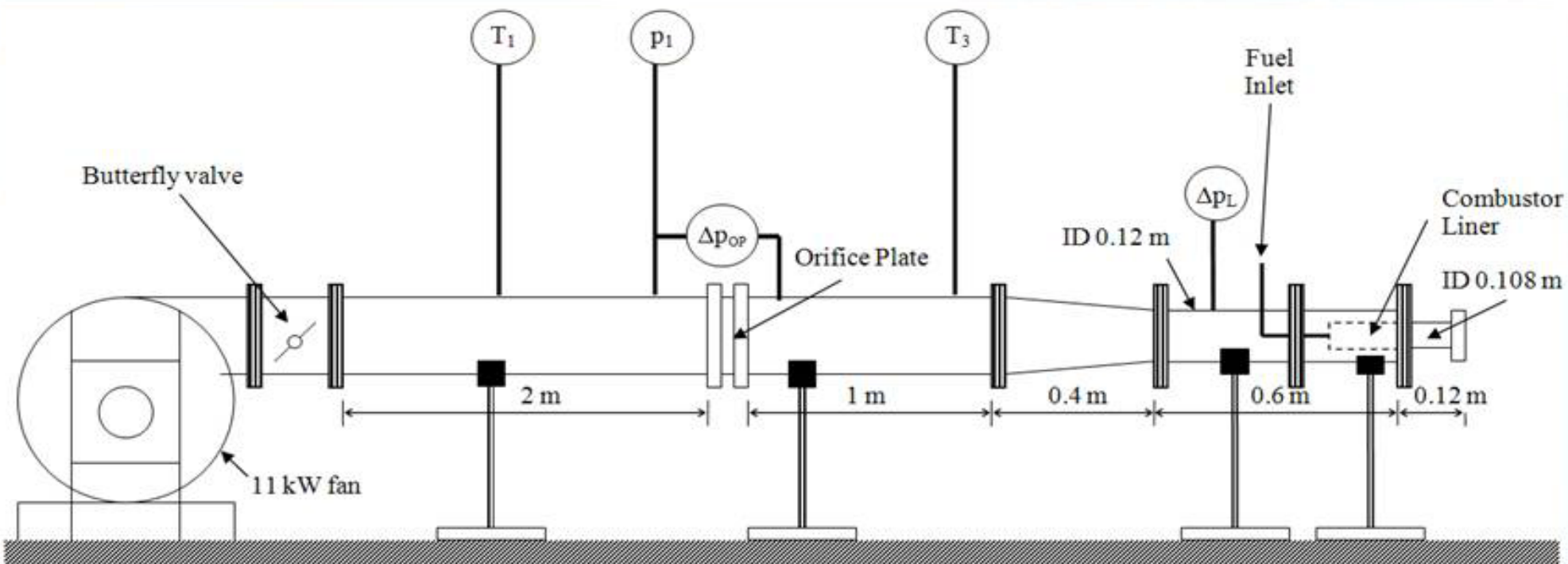



EXPERIMENTAL SETUP

- **Combustor liner:**
 - **Replica of reacting test combustor**
 - **Material: Perspex**
 - **230 mm long**
 - **Primary holes: 6 x Φ 9,5 mm**
 - **Secondary holes: 8 x Φ 5 mm**
 - **Dilution holes: 10 x Φ 11.8 mm**
 - **Nominal diameter of 98,4 mm**
 - **Primary cooling ring holes: 30 x 1,2 mm**
 - **Secondary cooling ring holes: 50 x 1,2 mm**





EXPERIMENTAL SETUP

- Swirler
 - Annular swirler
 - Surrounds injector nozzle
 - 10 x flat vanes at 50° to inlet plane
 - 7mm deep
- Casing
 - Φ 121,2 mm

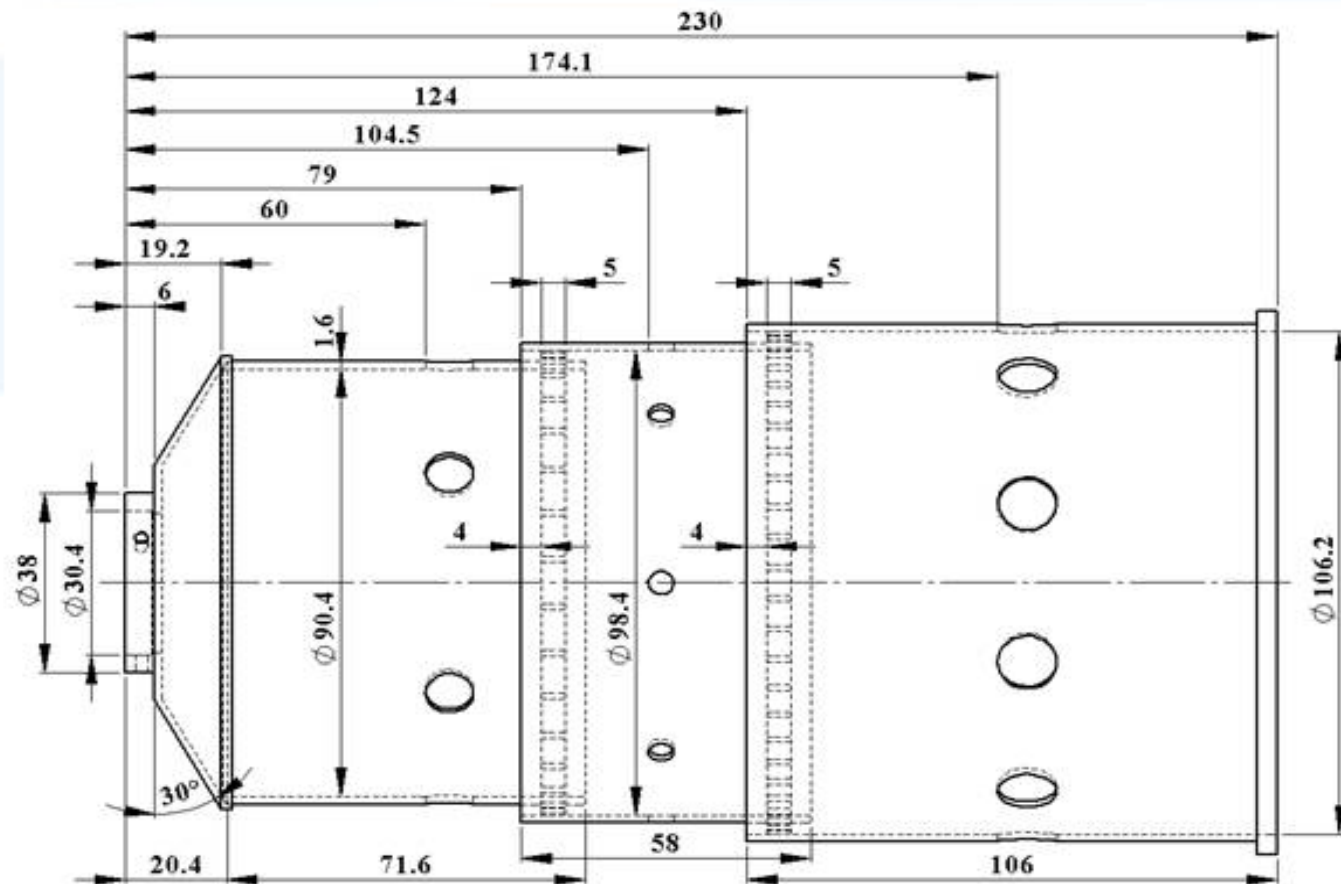
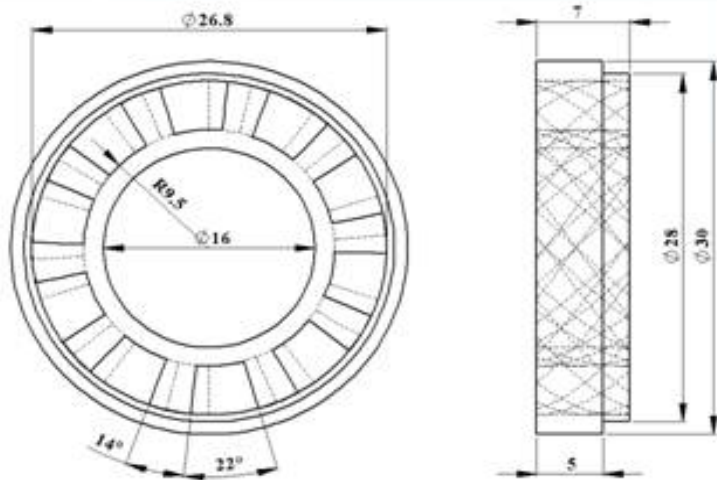



EXPERIMENTAL SETUP: THERMAL TESTS

- Outlet temperature plane → 5 thermocouple rake
- Outlet velocity profile → Pitot Tube
→ With & Without Combustion



EXPERIMENTAL SETUP: PIV

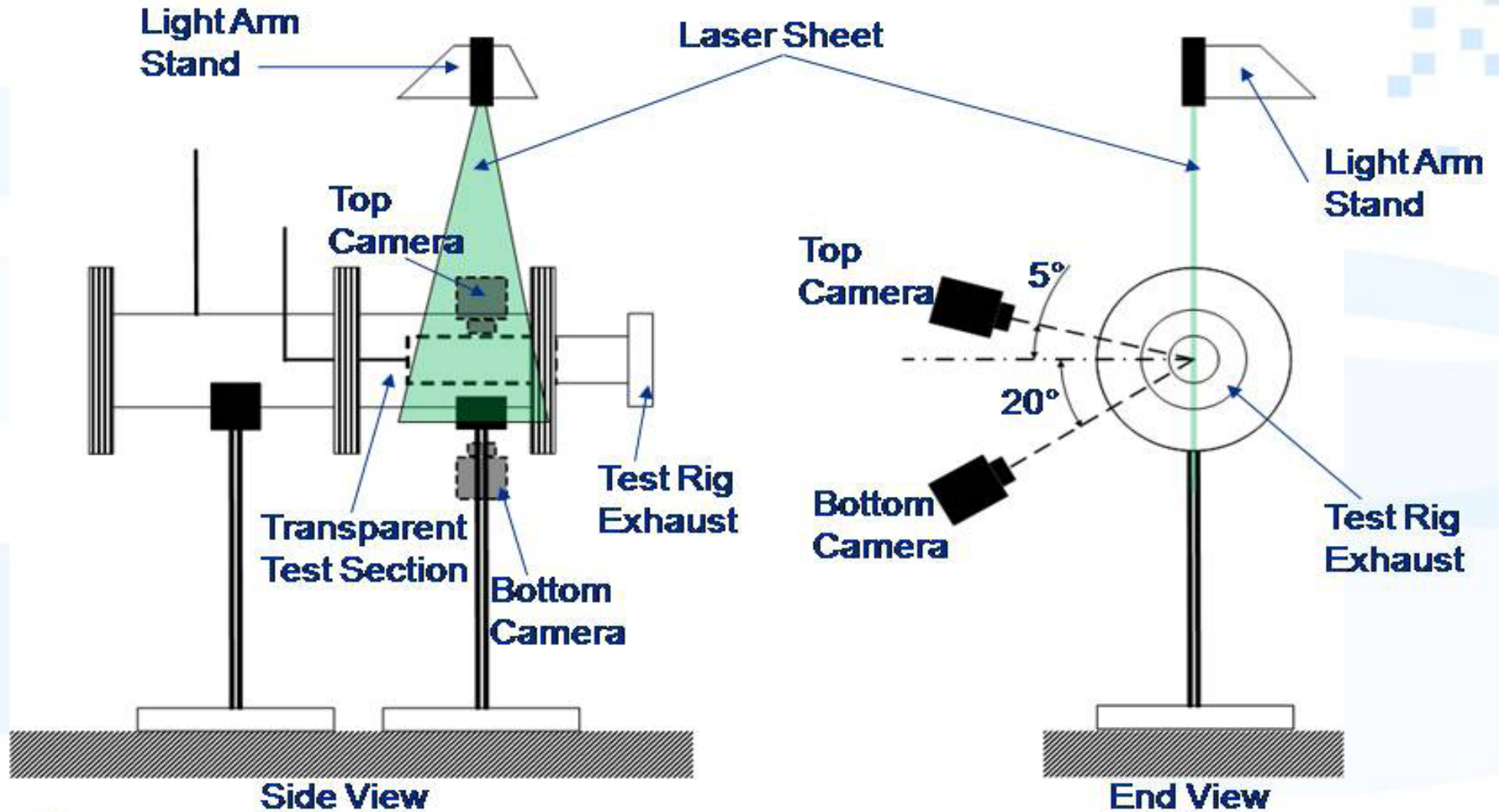

EXPERIMENTAL SETUP: PIV

- **PIV system:**
 - Dual laser heads
 - Q-switched
 - The laser sheet is in the axial plane entering from above
 - Laser light $\lambda = 532 \text{ nm}$
 - Laser sheet thickness = 1 to 1,5 mm
 - 2 x 4MP CCD cameras
 - Seeding = Smoke from burning oil

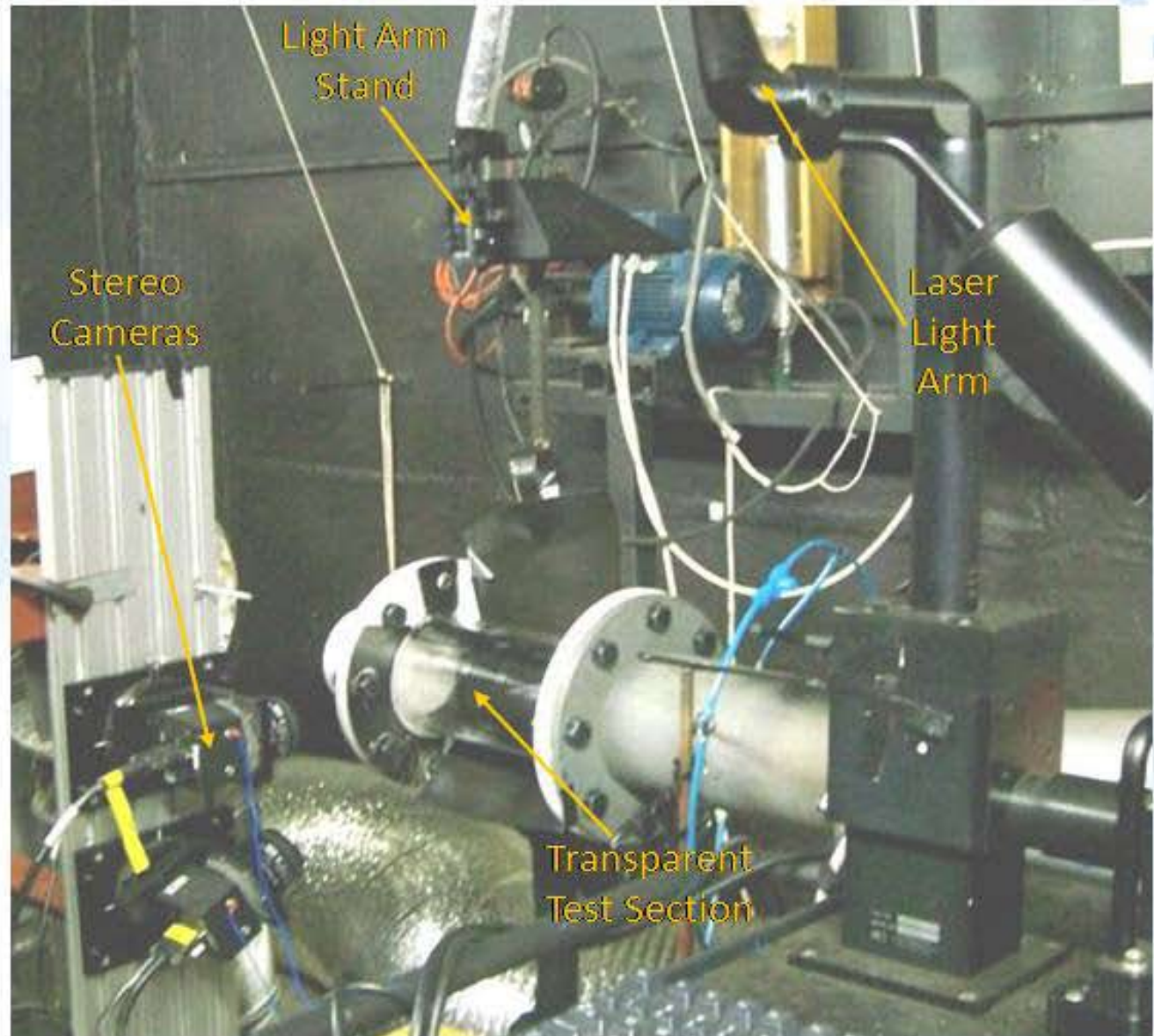



EXPERIMENTAL PROCEDURE: THERMAL TESTS

- Air mass flow rate = 0,091 kg/s (372,6 kg/h)
- Thermal Characteristics:
 - Rotate thermocouple rake 360°
 - Measure every 10°
 - Normalized Temperature = $\frac{T_{4i} - \bar{T}_3}{T_{AFT} - \bar{T}_3}$
 - Pattern factor = $\frac{T_{4max} - \bar{T}_4}{\bar{T}_4 - \bar{T}_3}$
 - Profile Factor = $\frac{T_{4mr} - \bar{T}_4}{\bar{T}_4 - \bar{T}_3}$
- Pressure characteristics:
 - Pressure loss factor = P_{34}/q_3
 - Overall Pressure loss = $P_{34}/P_3 \times 100$
- Velocity Profile:
 - Measure outlet velocity profile with pitot tube at 5mm intervals across diameter of outlet



EXPERIMENTAL PROCEDURE: PIV

- Base case Air mass flow rate = 0,056 kg/s (201,6 kg/h)
- ΔT between Laser Pulses:
 - Primary zone = 15 μ s
 - Secondary zone = 5 μ s
 - Dilution zone = 5 μ s

- Swirl Number = $Sn = \frac{2 \int_{-\frac{D_{CS}}{2}}^{\frac{D_{CS}}{2}} |UW r^2| dr}{D_{CS} \int_{-\frac{D_{CS}}{2}}^{\frac{D_{CS}}{2}} |U^2 r| dr}$

- Runs performed in line with the holes and in between the holes of the respective sections.



EXPERIMENTAL PROCEDURE : PIV

- Increase flow rate

Pressure drop over orifice plate	Corresponding air mass flow rate	
	[Pa]	[kg/s]
1000	0.056	201.6
1100	0.059	212.4
1300	0.064	230.4
1600	0.070	252.0
2000	0.078	280.8
2600	0.091	327.6

- Temporal indication
 - Compare consecutive frames



EXPERIMENTAL RESULTS: THERMAL TESTS

- $T_{\max} = 817 \text{ K}$
- $T_{\min} = 501 \text{ K}$
- Pattern factor = 0.70
- Profile factor = 0.54
- Overall pressure loss = 3.51%
- Pressure loss factor = 100.74

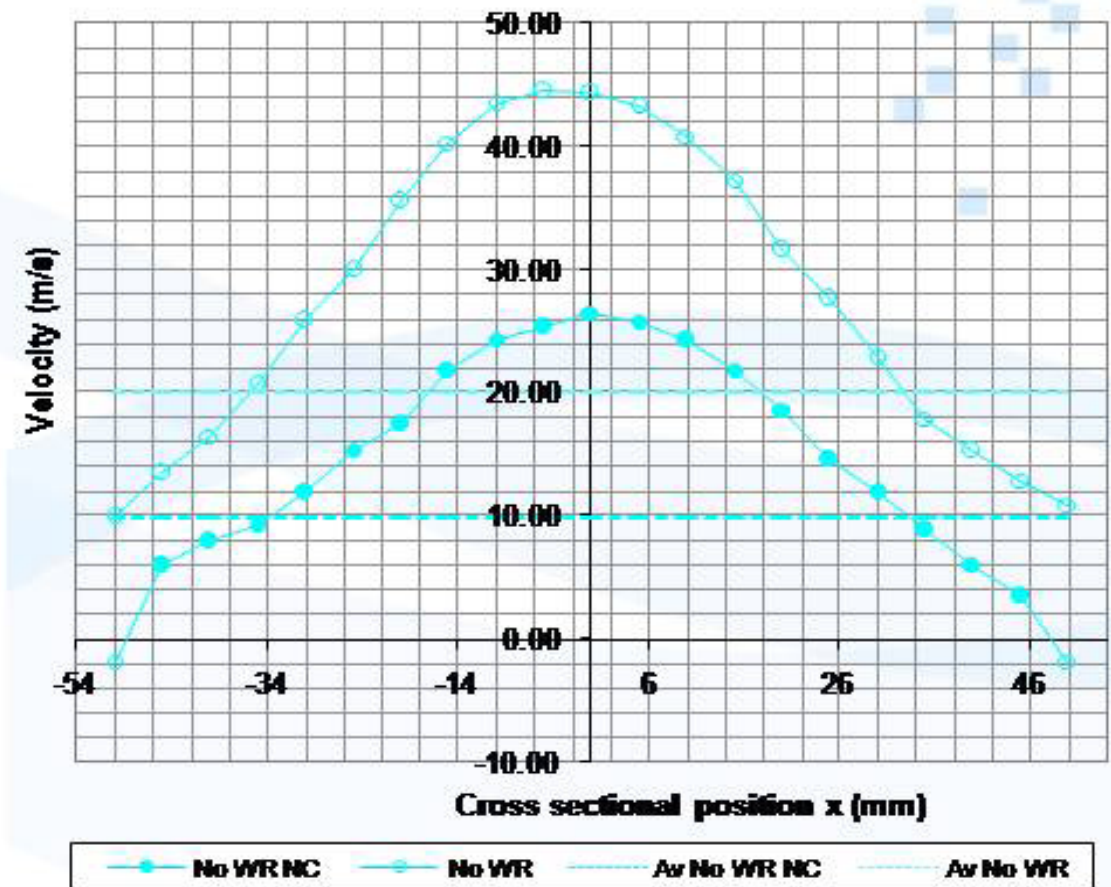
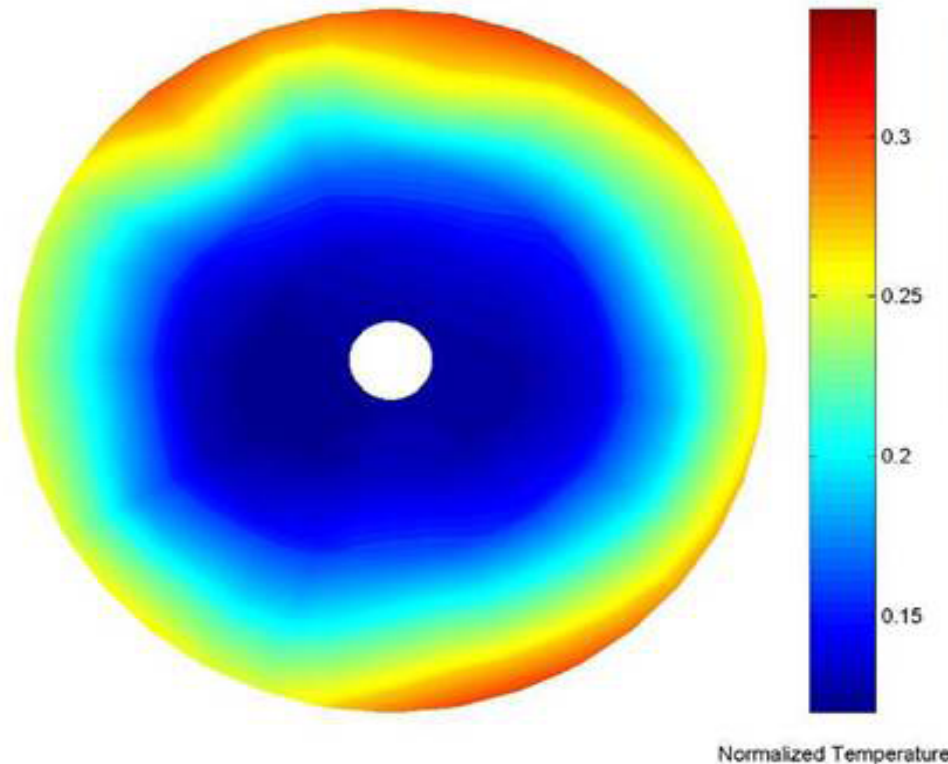

EXPERIMENTAL RESULTS: THERMAL TESTS



- **Blue flames** → Close to stoichiometric
→ Stationary
- **Orange flames** → Off stoichiometric
→ Likely rich
→ Constantly Moving and changing shape
- **135° to 225° no flame visible**
- **Top & bottom flame tongues present till secondary cooling ring**
- **Right flame tongue present till primary cooling ring**

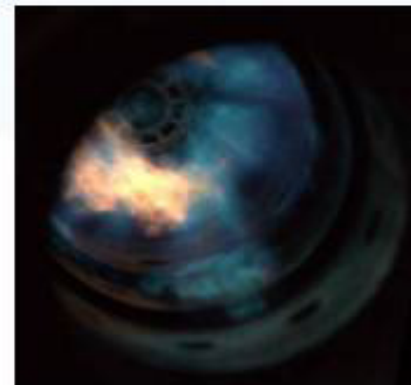
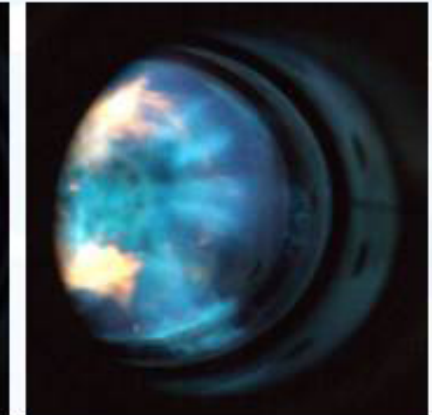
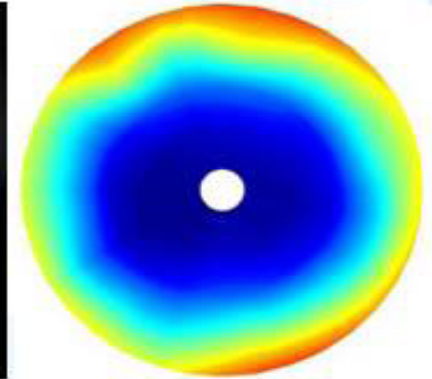
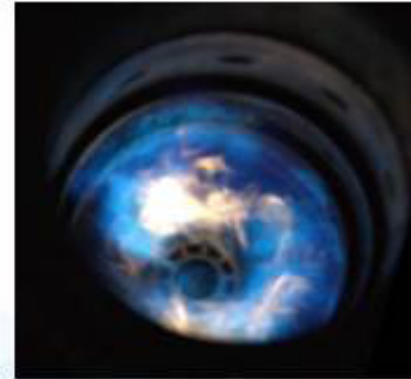

EXPERIMENTAL RESULTS: THERMAL TESTS

- **Dome: Uneven carbon pattern** → indicates skewed combustion already in the primary zone
- **Bottom, top and right: Burned away carbon** → corresponds to flame tongues
- **Left: carbon is not present but it is not known why.**

Perhaps → just the correct temperature and air combination → A non-visible flame present

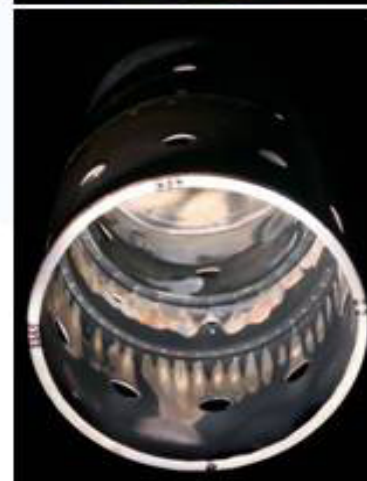
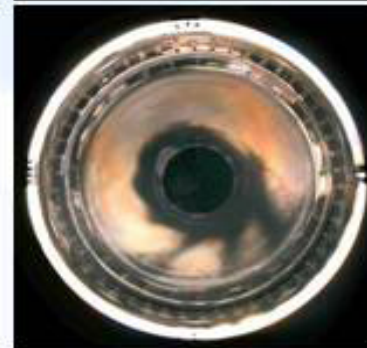
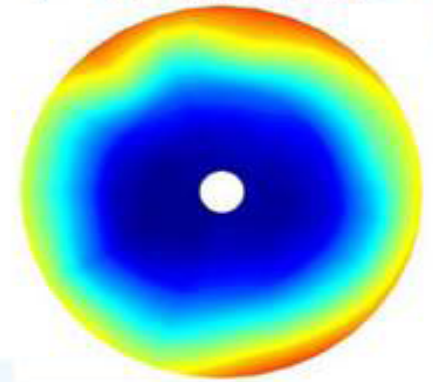

EXPERIMENTAL RESULTS: PIV BASE CASE



- **Velocity Magnitude contours with streamlines superimposed**
- **Top = in line with the holes**
- **Bottom = In between the holes**

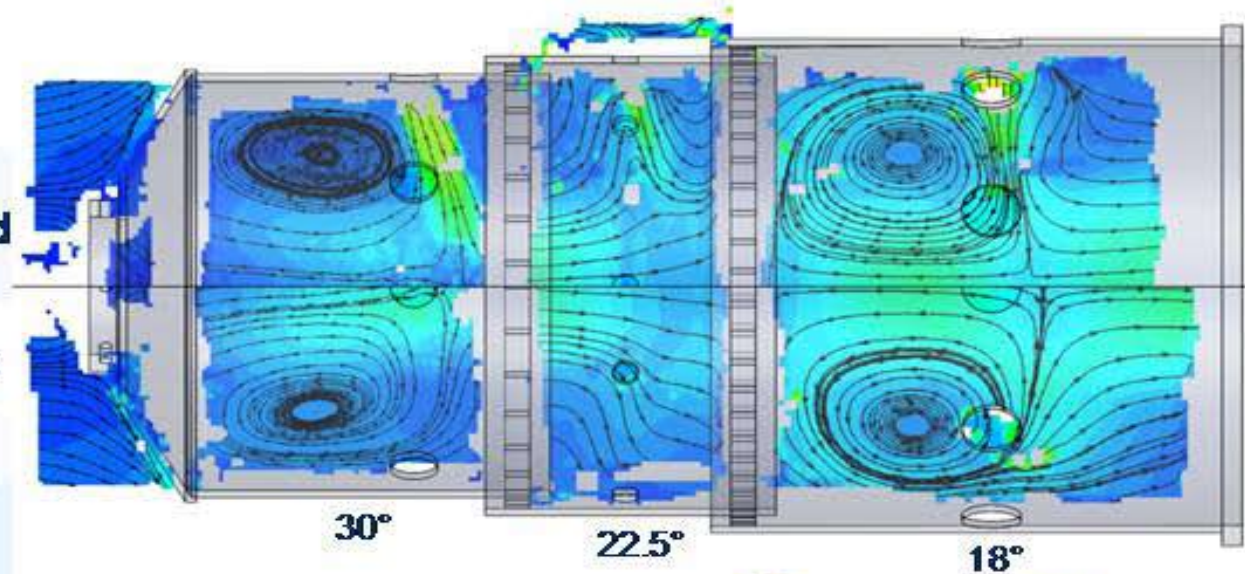

- **Major feature streamline paths shown for comparison**

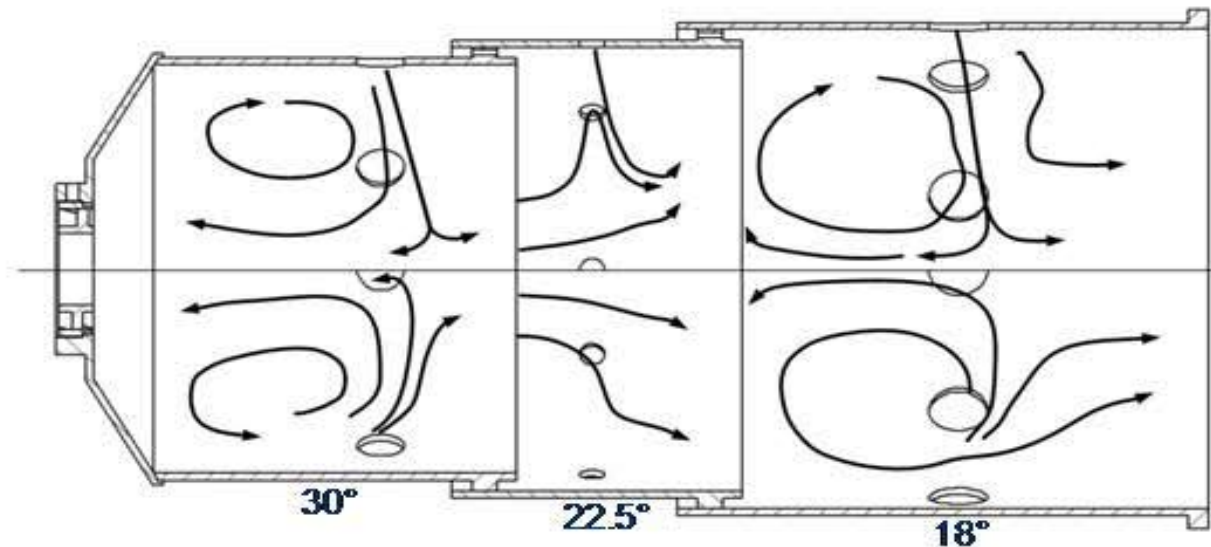



EXPERIMENTAL RESULTS: PIV BASE CASE

- The through plane velocity vector profiles at certain cross sections in line with the holes

W(m/s): -20 -10 0 10 20

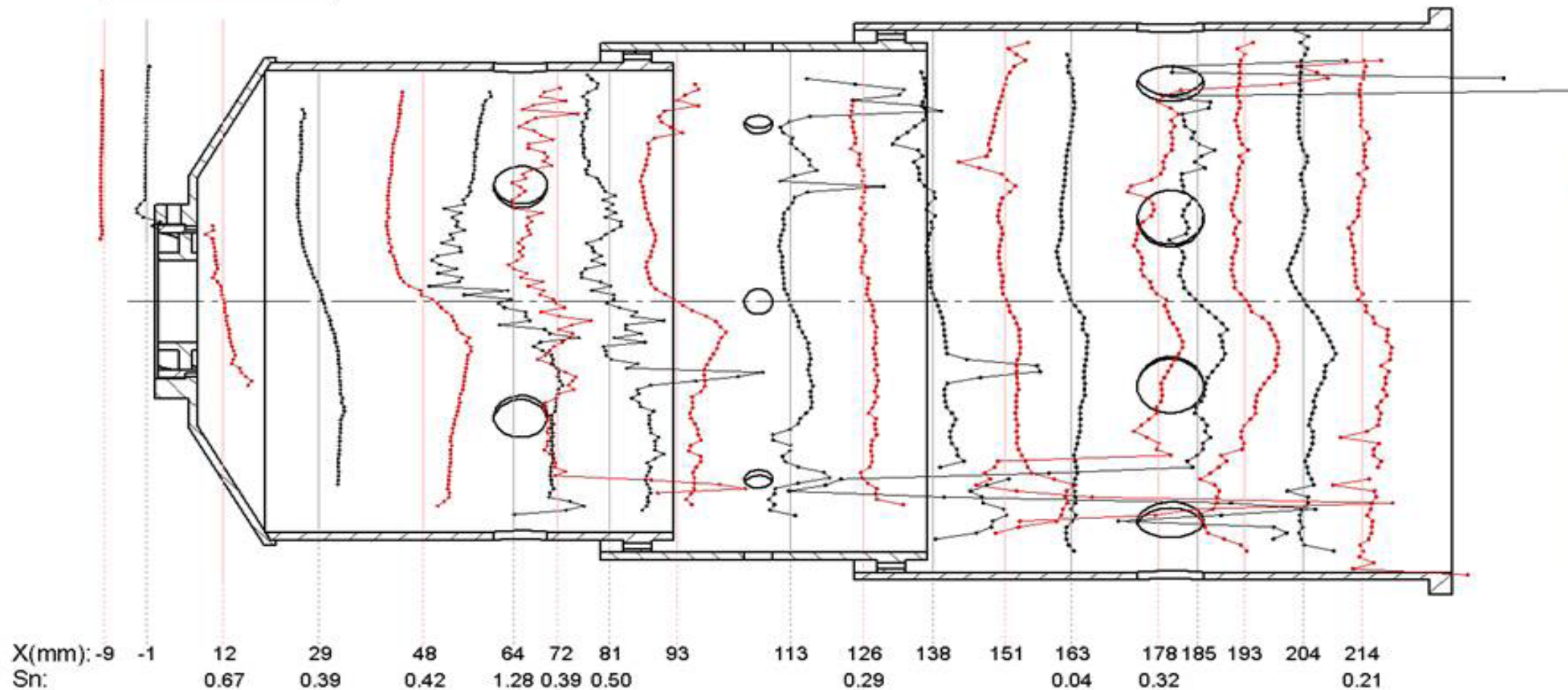



EXPERIMENTAL RESULTS: PIV BASE CASE

- The through plane velocity vector profiles at certain cross sections in between the holes

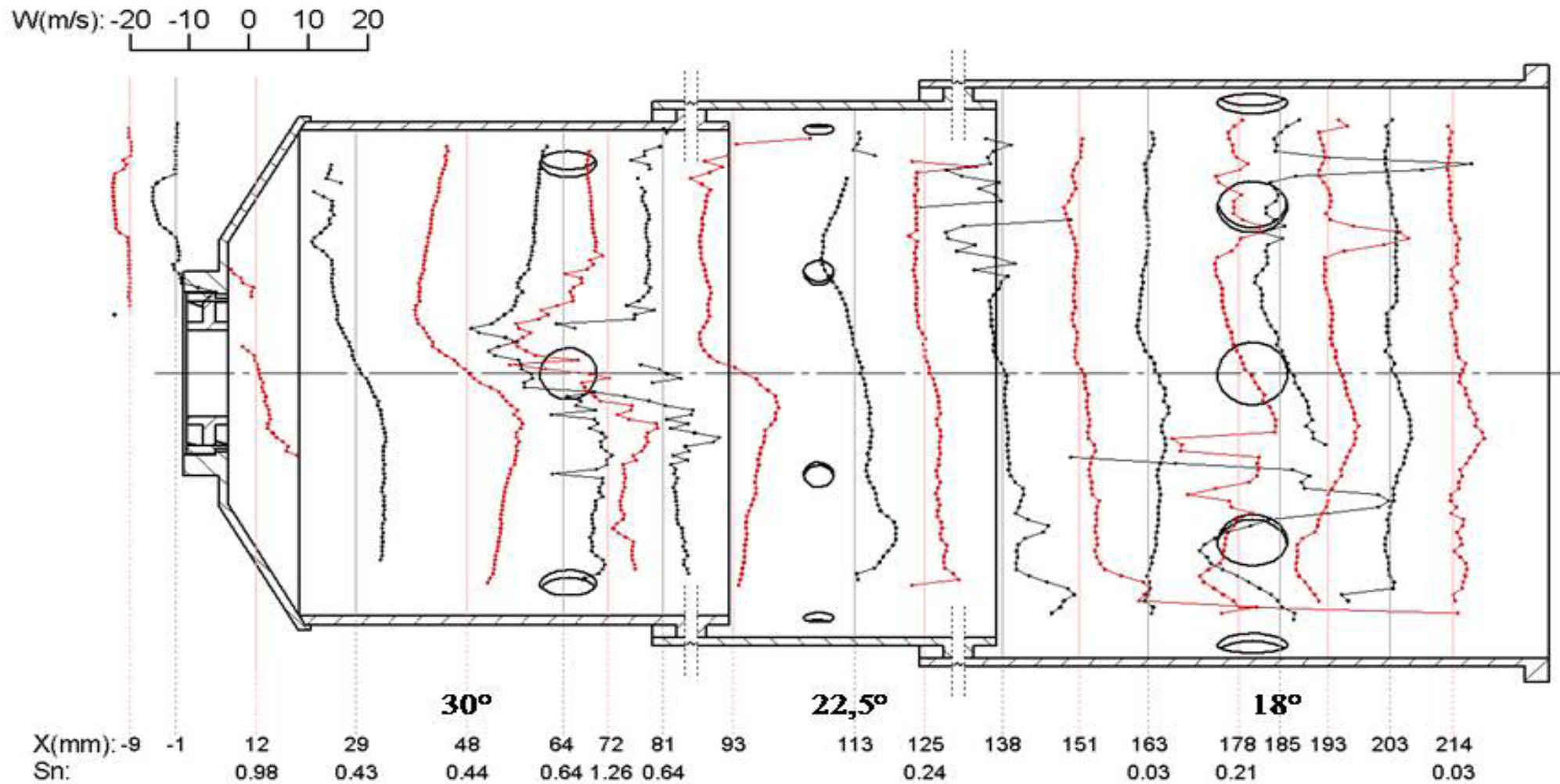



EXPERIMENTAL RESULTS: PIV INCREASING FLOW RATE

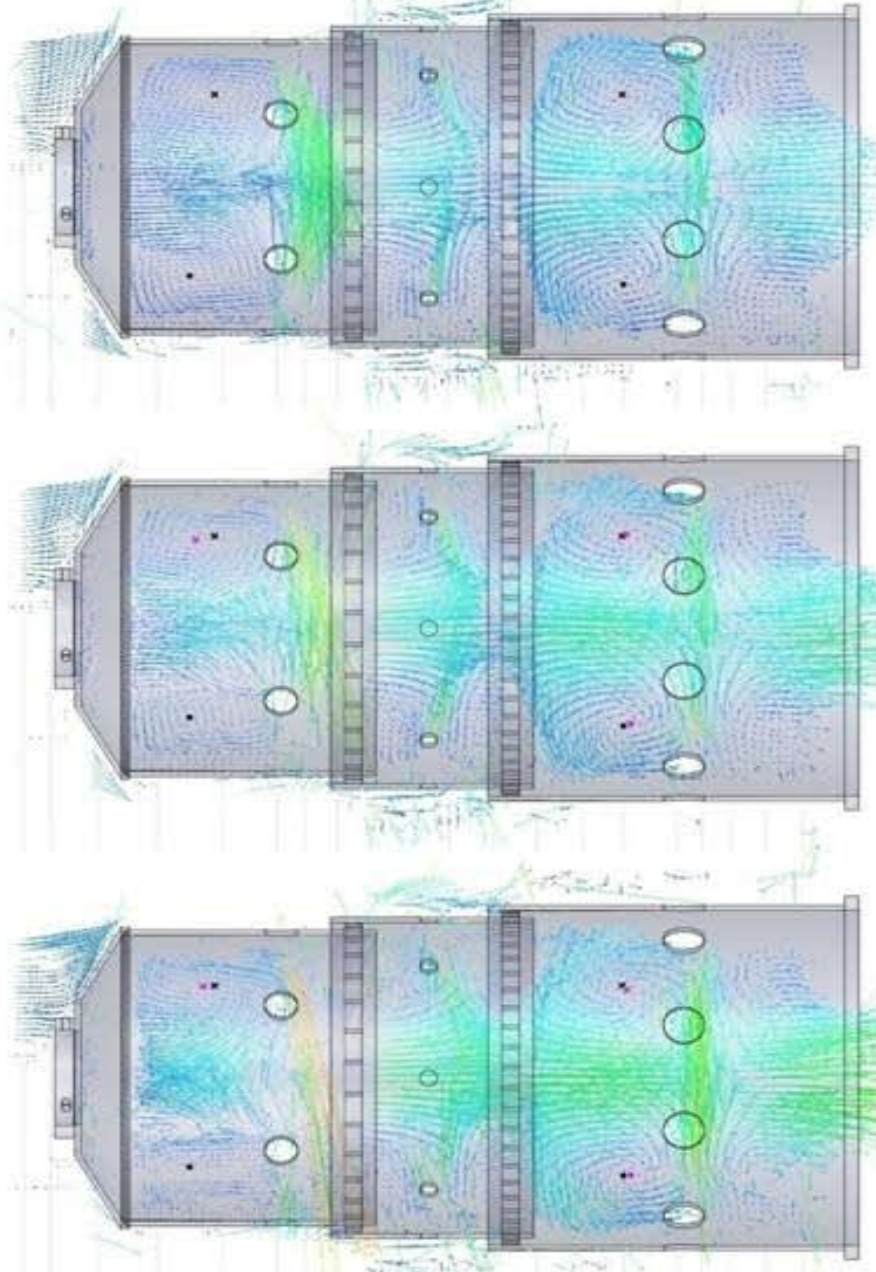
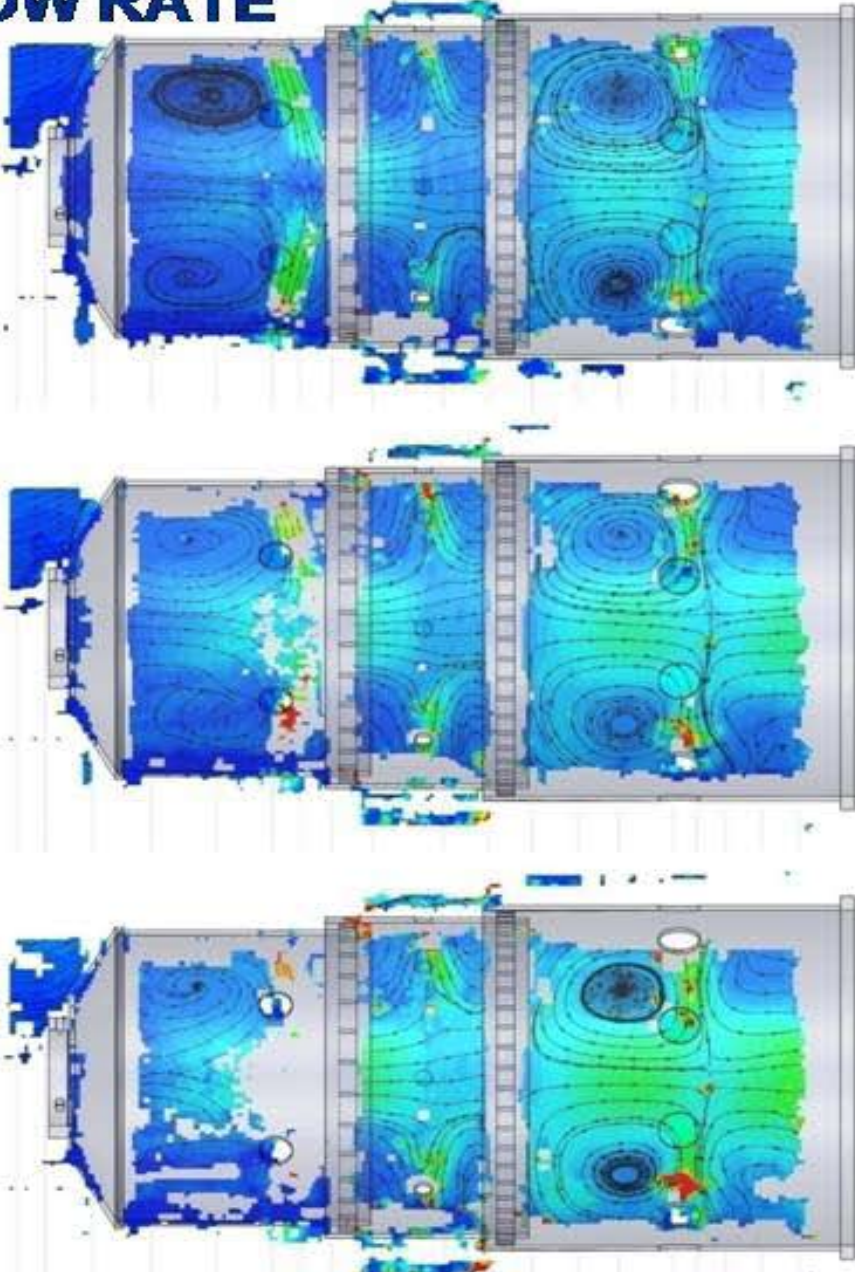
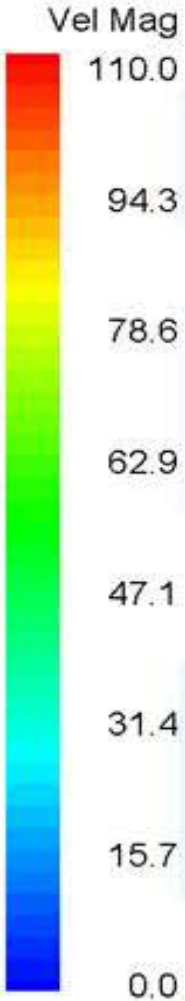

X(mm): -9 -1 12 29 48 64 72 81 93 113 126 138 151 163 178 186 193 204 214

X(mm): -9 -1 12 29 48 64 72 81 93 113 126 138 151 163 178 186 193 204 214



EXPERIMENTAL RESULTS: PIV INCREASING FLOW RATE

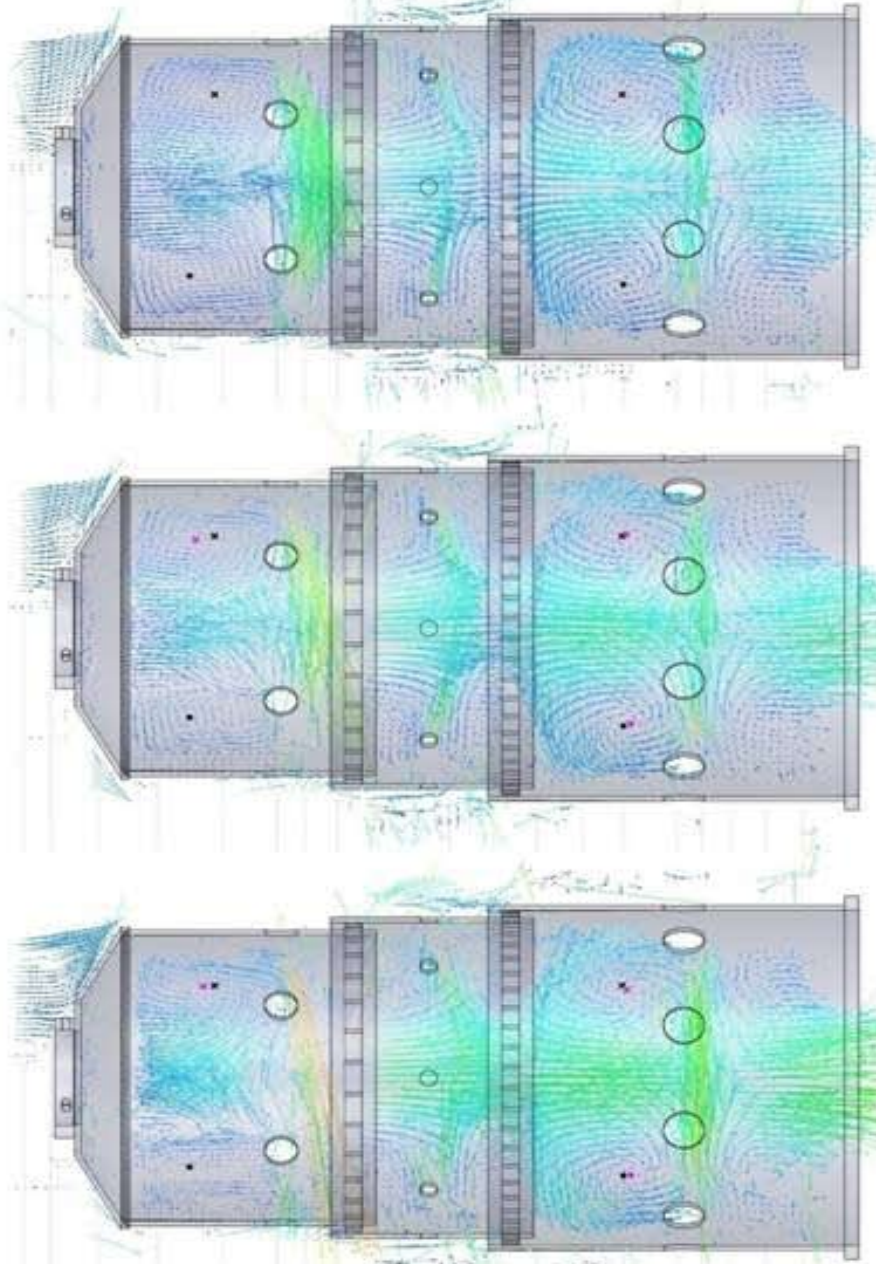
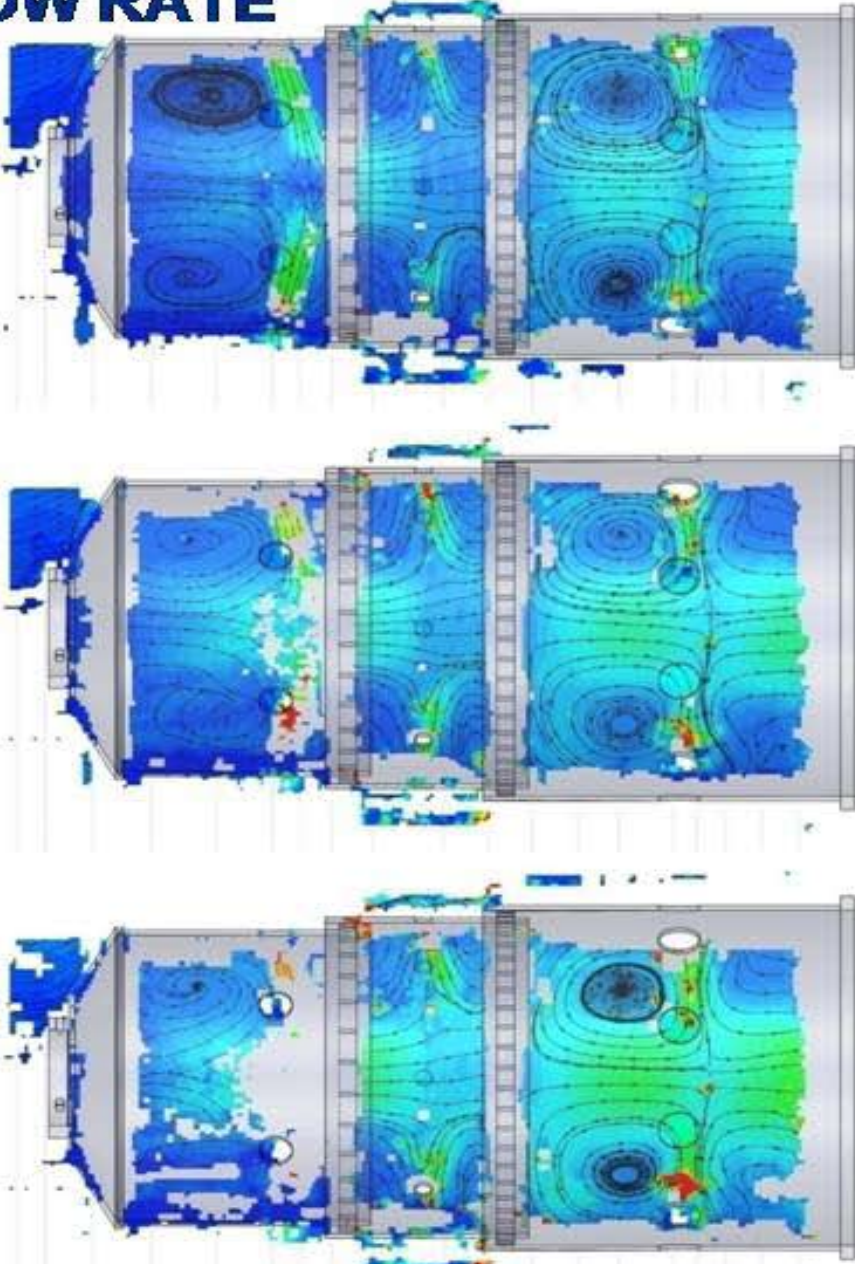

X(mm): -9 -1 12 29 48 64 72 81 93 113 126 138 151 163 178 186 193 204 214

X(mm): -9 -1 12 29 48 64 72 81 93 113 126 138 151 163 178 186 193 204 214

EXPERIMENTAL RESULTS: PIV INCREASING FLOW RATE

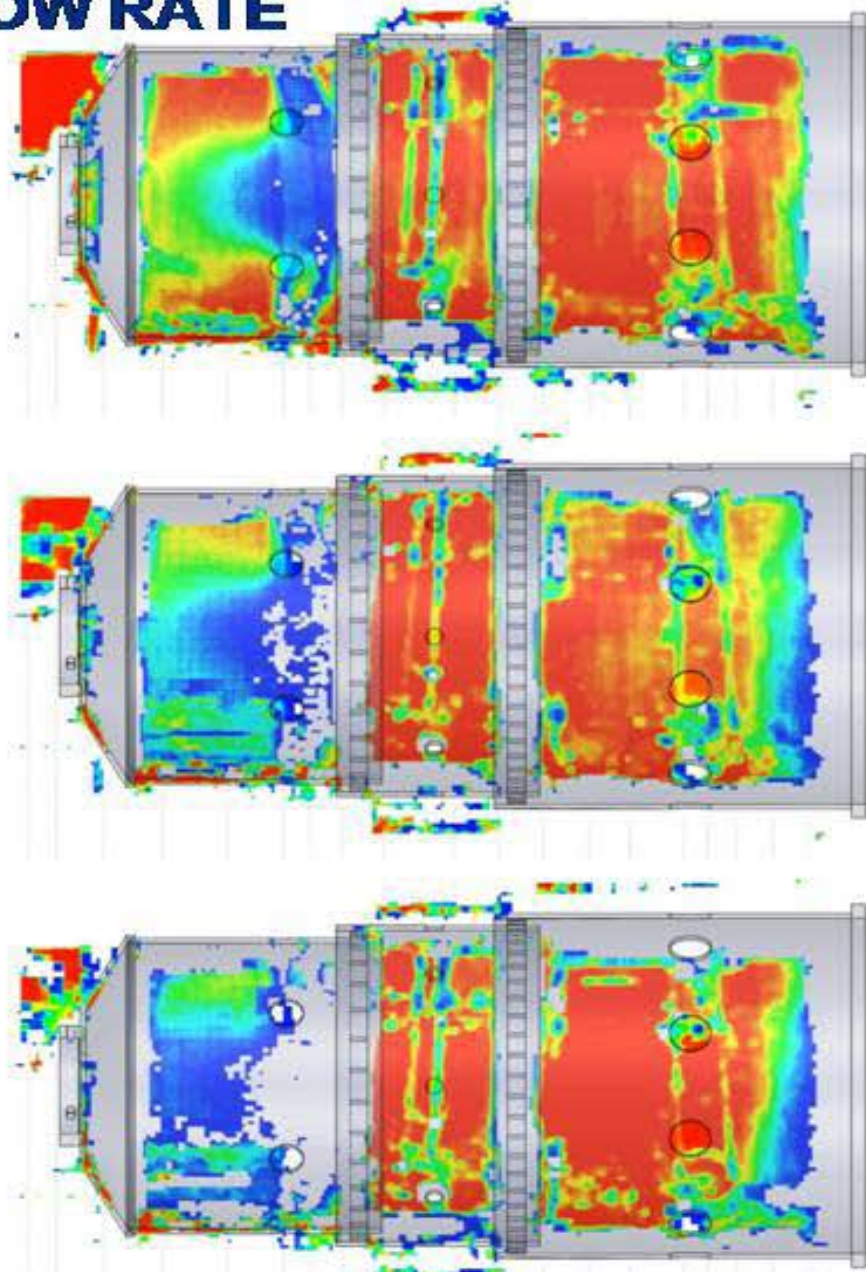

W(m/s): -20 -10 0 10 20

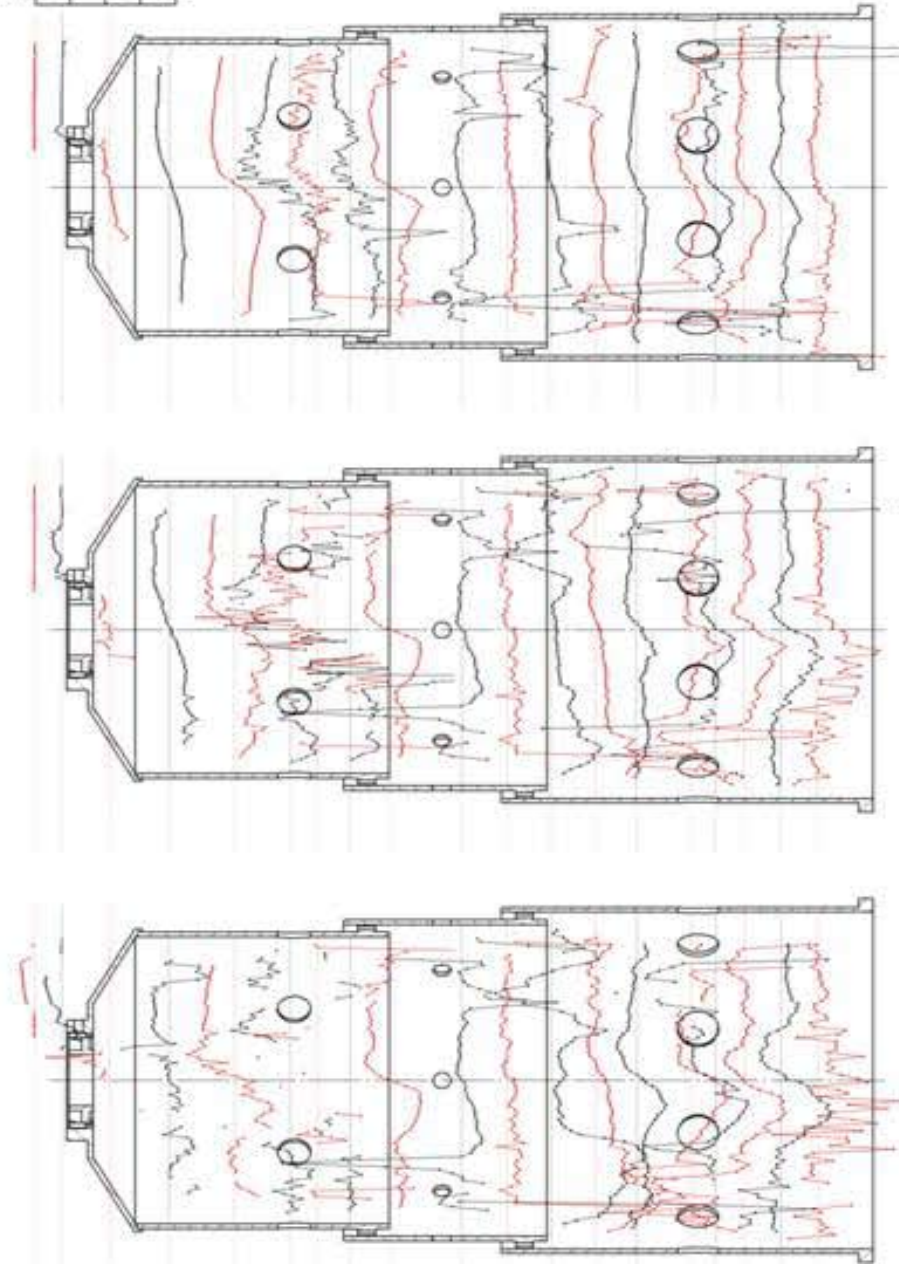

X(mm): -9 -1 12 29 48 64 72 81 93 113 126 138 151 163 178 186 193 204 214

X(mm): -9 -1 12 29 48 64 72 81 93 113 126 138 151 163 178 186 193 204 214

EXPERIMENTAL RESULTS: PIV TEMPORAL INDICATION



- Recirculation zone varies:

Image a) → Rz is well defined

Image d) → Rz broken down

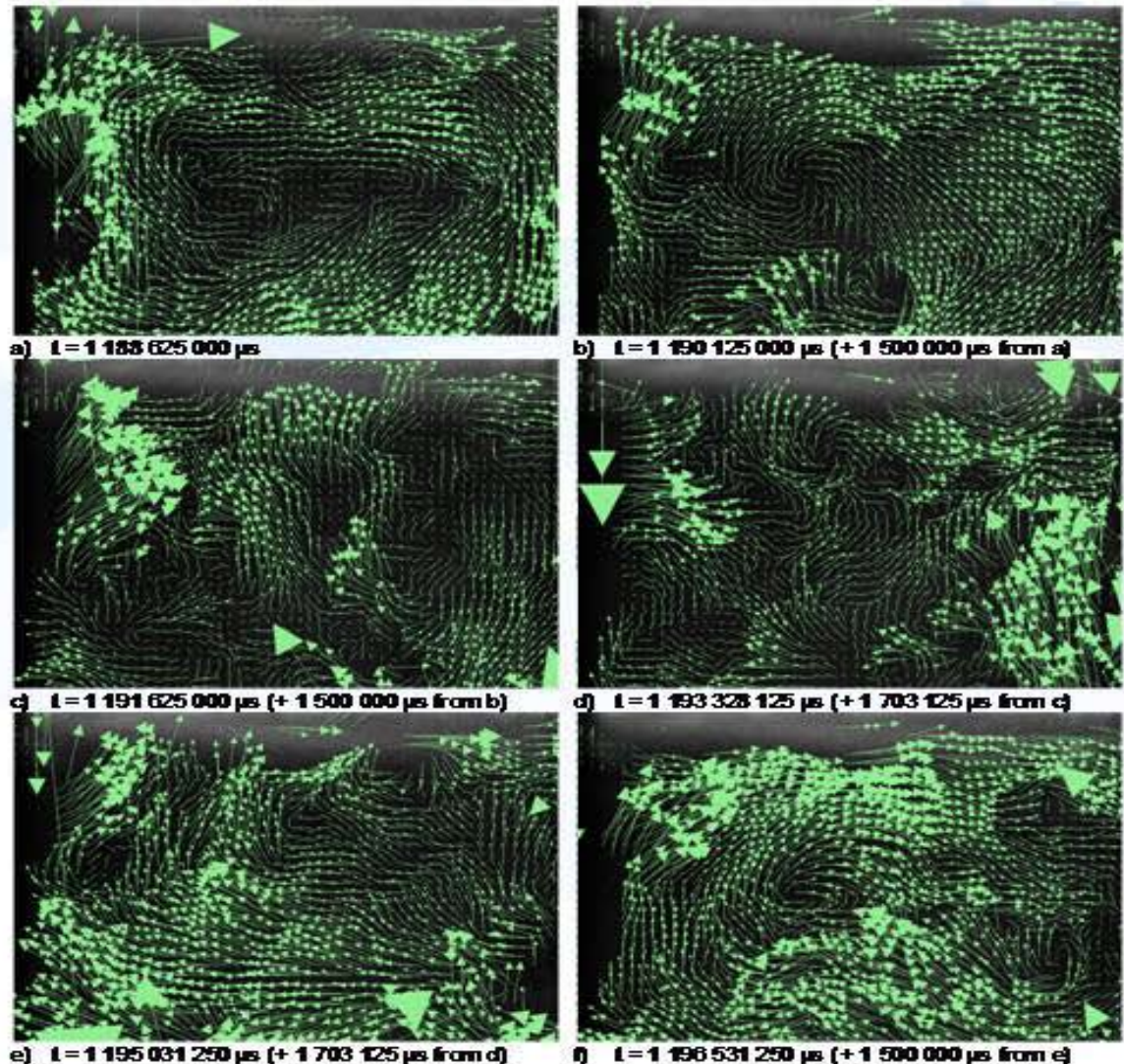

EXPERIMENTAL RESULTS: PIV TEMPORAL INDICATION

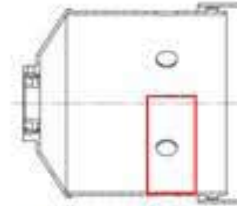

- The angle of the jet fluctuates between 16° to 27° with respect to the verticle

- a) = 25°
- b) = 18°
- c) = 20°
- d) = 16°
- e) = 27°
- f) = 23°

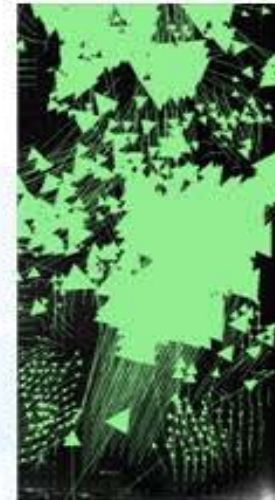

a) $t = 1\ 188\ 825\ 000\ \mu\text{s}$



b) $t = 1\ 190\ 125\ 000\ \mu\text{s}$
(+ $1\ 500\ 000\ \mu\text{s}$ from a)



c) $t = 1\ 191\ 625\ 000\ \mu\text{s}$
(+ $1\ 500\ 000\ \mu\text{s}$ from b)

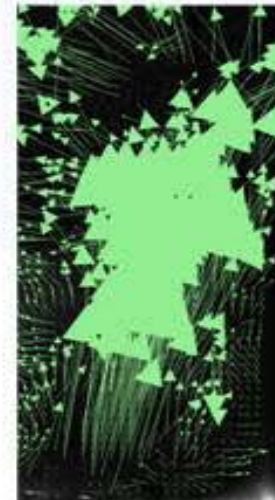

d) $t = 1\ 193\ 328\ 125\ \mu\text{s}$
(+ $1\ 703\ 125\ \mu\text{s}$ from c)

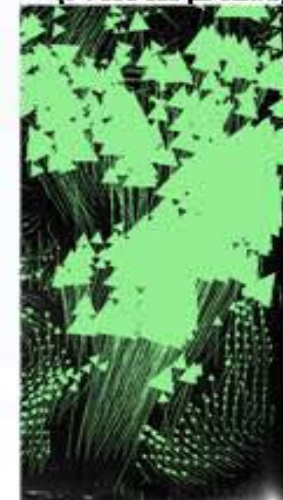

e) $t = 1\ 195\ 031\ 250\ \mu\text{s}$
(+ $1\ 703\ 125\ \mu\text{s}$ from d)

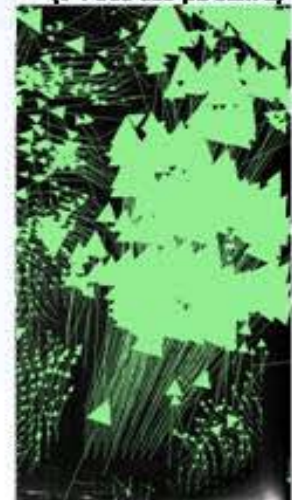

f) $t = 1\ 196\ 531\ 250\ \mu\text{s}$
(+ $1\ 500\ 000\ \mu\text{s}$ from e)



CONCLUSION

- **Reacting Experiment**
 - The outlet temperature profile is the most important feature to model correctly
 - The outlet temperature profile measured shows enough detail to compare to CFD
- **Non-reacting Experiment**
 - The PIV data has a large amount of detail
 - The primary recirculation zone size and position can be used to indicate how well the turbulence model is performing in simulating flow with both swirling and jet flow
 - The tangential flow measurements can be used to evaluate how well the swirling flow is modeled
 - The dilution recirculation zone is atypical and can thus be used to test how well the CFD captures real flow features
 - The flow data also yields the jet penetration depths which should also be modeled well because it influences the rate of mixing