

# A SOUTH AFRICAN INITIATIVE FOR PRE-FLIGHT RADIOMETRIC CALIBRATION OF SATELLITE IMAGERS

*D. Griffith, M. D. Lysko, D. Bezuidenhout*

CSIR, South Africa  
dgriffith@csir.co.za, mlysko@csir.co.za, dbezuide@csir.co.za  
<http://www.csir.co.za/>

## ABSTRACT

Internationally, the remote observation of Earth is rapidly maturing alongside the need for higher accuracy in radiance measurements. Accuracy of, and confidence in Earth radiance measurements is vital for applications such as climate change analysis and the forecasting and detection of natural hazards. The radiance accuracy depends on pre-launch calibration of the observing instruments and continuous post-launch sensor assessment. South Africa, a country on the brink of taking a giant leap into space, is preparing a facility for spectral radiance calibration of satellite imagers. This paper describes the pre-flight radiometric calibration facility.

*Index Terms*— radiometry, satellite imager, calibration

## 1. INTRODUCTION

Internationally, the remote observation of Earth is rapidly maturing alongside the need for higher accuracy in radiance measurements. Accuracy of, and confidence in Earth radiance measurements is vital for applications such as climate change analysis and the forecasting and detection of natural hazards. The radiance accuracy depends on pre-launch calibration of the observing instruments and continuous post-launch sensor assessment. South Africa, a country on the brink of taking a giant leap into space [1], is preparing a facility for spectral irradiance and radiance calibration of satellite imagers.

The country's Department of Science and Technology (DST) has commissioned the Council for Scientific and Industrial Research (CSIR) to establish a radiometric calibration facility at Houwteq, which is situated in the mountains to the east of Cape Town. The facility is presently designed to calibrate a SunSpace linescan charge-coupled-device (CCD) imager and can be rearranged to meet other calibration needs.

Financial constraints have prohibited the implementation of a tunable laser system (such as described in [2] and [3]) for

combined spectral and absolute radiometric response and therefore a more traditional approach to the problem has been adopted.

Hence the facility comprises a uniform source integrating sphere with conventional lamps for absolute radiance response calibration and a multi-grating turret monochromator system for the relative spectral response calibration.

The calibration hardware is housed in a class 100 000 clean room area.

## 2. ABSOLUTE RADIOMETRIC CALIBRATION

Absolute radiometric calibration is performed using a LabSphere USS4000C integrating sphere furnished with a set of Quartz Tungsten Halogen (QTH) lamps driven by precision current controllers. This integrating sphere is 102 cm in diameter and has a 36 cm exit port. These dimensions place a practical constraint on the optical aperture of the Unit-Under-Test (UUT) that can be accommodated. The radiance and radiance uniformity are traceable to NIST. The sphere also has an additional external QTH source which feeds into the sphere via a continuously adjustable flux shutter. This allows linearity measurements to be performed on the UUT over the full radiance range of the sphere. Linearity may be of particular interest at low radiance and near saturation.

The sphere is monitored with an integrated photometer and externally with a traceable spectroradiometer. There are two spectroradiometers available for this purpose, the Photo-Research PR715 as well as the ASD FieldSpec 3. The PR715 covers the visible and near-infrared spectrum, while the ASD instrument covers the spectral range from 350 nm to 2500 nm. The preferred mode of operation is to monitor the spectral radiance of the sphere continuously during calibration of the UUT.

### 3. RELATIVE SPECTRAL CALIBRATION

#### 3.1. Concept and Layout

The relative spectral calibration is performed on a vibration-isolated optical table. The optical train comprises the following elements, some of which are labeled in the schematic shown in Figure 1:

- a) A stabilized light source, being either a QTH source or a Xenon arc source, depending on which is more suitable for the task at hand. The light output is stabilized in a closed loop using a detector positioned near the source.
- b) A refractive collimator, a heat absorbing filter, holographic diffuser and focusing lens.
- c) An order sorting filter wheel.
- d) An adjustable or optionally a fixed width input slit.
- e) A Newport-Oriel MS257 imaging monochromator with a 4-grating turret. The turret in this monochromator has the property that wavelength scanning is performed with the grating coincident with the scanning axis. Alternative turrets and gratings can be fitted for different wavelength

regions.

- f) An adjustable or alternatively a fixed width exit slit.
- g) An optional holographic diffuser to trade off the peak radiance of the source against the size of the source presented to the UUT.
- h) A crystal quartz wedge pseudo-depolarizer. This is required to offset the polarization effects introduced by the monochromator.
- i) A fold mirror for alignment and to raise the optical axis to the height required by the UUT.
- j) A 360 mm diameter spherical mirror that serves to collimate the beam from the monochromator. This collimator places a limit on the aperture of UUTs that can be accommodated.
- k) A reference detector module for relative spectral calibration of the collimated beam.
- l) An alignment module for alignment of the reference detector module or the UUT to the collimated beam coming from the monochromator.
- m) A mounting region for the UUT.

Calibration measurements are automated using LabView.

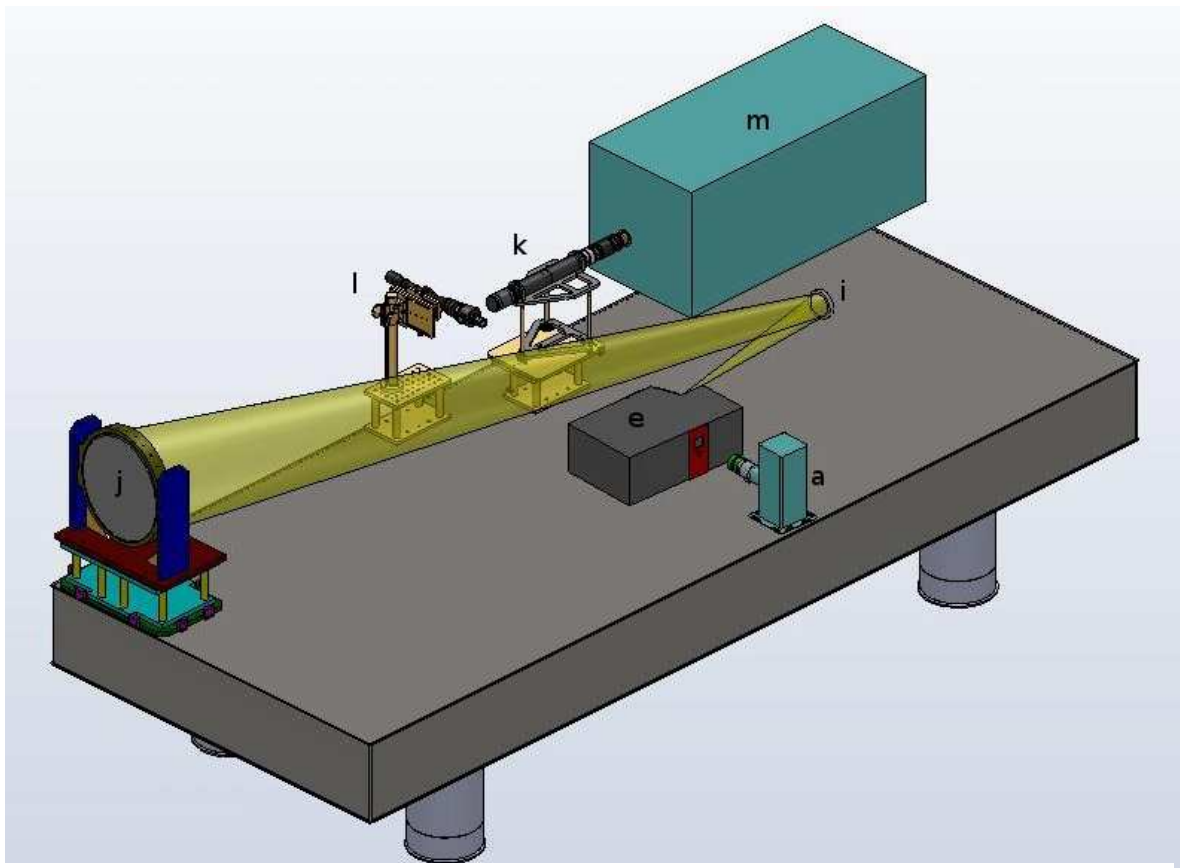

Figure 1: Schematic of Spectral Calibration Bench

### 3.2. Radiometric Modeling

The relative spectral calibration system has a computer based model. The beam imaging, collimating and analysis is done with the ZEMAX optical system design program. Calculation of the radiance and flux throughput is done using the Matlab R2008b computation software package.

The monochromator system is unique in the sense that it incorporates a relatively uniform light input, has a grating selection for improved efficiency and meets the required throughput level. The quasi-monochromatic output is depolarized and then reflected off custom made mirrors such that the final collimated beam overfills the 280 mm aperture of the UUT under consideration. The system currently has a spectral range from 400 nm to 900 nm and the coverage can be extended to the ultraviolet and infrared if needed. The spectral resolution can be varied and is currently set for 2 nm or 4 nm depending on required throughput.

### 3.3. Reference Detector Module

A calibrated silicon detector is used as the reference standard. The detector is furnished with an afocal telescope to increase the effective detector size, to provide baffling against straylight and to restrict the field of view. The spectral transmission of the reference detector telescope has been measured using a Photo-Research PR715 spectroradiometer in conjunction with a stabilized integrating sphere source.

### 3.4. Alignment Module

The alignment module comprises a zoom telescope which views both the UUT focal plane and the monochromator exit slit. This is possible through the use of a beamsplitter and a corner cube reflector. The UUT focal plane is illuminated with an additional light source to allow the exit slit of the monochromator to be aligned to specific areas on the focal plane.

## 4. OTHER RADIOMETRIC CHARACTERIZATIONS

The equipment described above can be reconfigured to perform a number of other radiometric characterizations.

### 4.3. Polarization Sensitivity

Polarization sensitivity of the UUT can be evaluated using the large integrating sphere as a source. Linear polarization of the source is introduced at a known orientation using a Glan-Thomson prism which is positioned at the focal plane of the large reflective collimator. Measurements of the variations in the output signal of the UUT at different prism orientations characterize the polarization sensitivity.

### 4.3. Stray Light

Stray light suppression performance of earth observing cameras is an important metric. The above equipment can be

used to perform characterization of both the in-field and out-of-field stray light susceptibility of the UUT. The large integrating sphere is used as a source at various standoff distances to evaluate out-of-field stray light contributions. In-field stray light can be evaluated using the reflective collimator with a light trap positioned at the focal plane which is then back-lit by the large integrating sphere.

The Point Source Transmittance (PST) function can be evaluated by using a highly intense point source (such as the arc lamp) projected into the UUT via the reflective collimator at various field angles. The dynamic range of this measurement depends on the irradiance level generated at the aperture of the UUT.

### 4.4. Saturation Level

Verification of the saturation radiance of the UUT may be desirable. Generally this requires an intense and relatively uniform source of known but continuously variable radiance. One method of modulating the radiance is to polarize the source using a Glan-Thomson prism, then to modulate using a second Glan-Thomson prism. The resulting beam should be depolarized either with an optically thick diffuser (e.g. flashed opal) or with a pseudo-depolarizer if the loss of light at such a diffuser is unacceptable.

## 5. SUMMARY

The above described South African facility for the pre-flight calibration of satellite imagers will contribute in the building of resident space capacity. Local expertise is also involved in projects for continuous post-launch sensor assessment. Between the facility and the latter mentioned initiatives there can be quantitative confidence in Earth radiance measurements with locally calibrated space instruments.

## 6. REFERENCES

- [1] CSIR Communication, *Space Science and Technology*, Vol. 3, No. 2, October 2009
- [2] K. R. Lykke, P.-S. Shaw, L. M. Hanssen, G. P. Eppeldauer, "Development of a monochromatic, uniform source facility for calibration of radiance and irradiance detectors from 0.2  $\mu\text{m}$  to 12  $\mu\text{m}$ ", *Metrologia*, 35, 479-484, 1998.
- [3] S. W. Brown, G. P. Eppeldauer and K. R. Lykke, "NIST facility for Spectral Irradiance and Radiance Responsivity Calibrations with Uniform Sources", *Metrologia*, 37, 579-582, 2000.

## ACKNOWLEDGEMENTS

The authors thank the Department of Science and Technology for funding this project and for permission to present this paper. We also thank SunSpace and the staff at Houwteq as well as CSIR staff for their assistance during commissioning.