

SIMRAC

Final Report

Title: REVIEW OF CURRENT DESIGN METHODOLOGIES
TO IMPROVE THE SAFETY OF ROOF SUPPORT
SYSTEMS, PARTICULARLY IN THE FACE AREA IN
COLLIERIES

Author/s: I CANBULAT; B JACK

**Research
Agency:** CSIR MINING TECHNOLOGY

Project No: COL 328
Date: MAY 1999

Executive Summary

This research report summarizes an extensive literature survey on roofbolt support design methods used worldwide, and presents the findings of extensive underground roof monitoring conducted in 29 sites at five collieries. An analysis of fall of ground fatalities covering the period 1989 to 1995 is also presented. The results showed that fall of ground accidents still remain the largest single cause of fatalities and injuries in South African collieries. The risk to the individuals going underground has not shown a significant increase or decrease over the 27 year period (1970 - 1996). Various forms of analysis were not possible because of inadequate or unavailable data. It is therefore necessary that reporting of FOG fatalities is improved and that additional data to normalise various aspects of accidents should be collected industry-wide.

A literature survey was conducted to investigate roof support mechanisms world-wide. The survey highlighted the fact that different roof support methods have been used for various failure mechanisms. The magnitudes of deformation and stress are also found to be important parameters in determining roof support requirements.

An extensive underground roof monitoring programme was conducted. Results showed that, in drill and blast sections, there are often pre-existing openings in the roof which has an effect on the overall roof stability. In drill and blast sections, 42 per cent of the total roof displacement takes place prior to the installation of support. A comparison between roadways and intersections indicated that, for a 40 per cent increase in the span, taken across the diagonal of an intersection, relative to the roadway span, the magnitude of the displacement in the roof increased by a factor of three. The results also showed no evidence of a substantial increase in the height of the bed separated, potential unstable roof strata, as is the case in the high horizontal stress driven beam buckling mechanism experienced in the overseas coal mines. Therefore, it was concluded that, in South African collieries, the magnitude of horizontal stresses is relatively low compared to overseas collieries.

A roadway widening experiment highlighted the variations that occur in a single mining area. It was also apparent that with experience, underground personnel develop the ability to recognise the presence of horizontal stress as soon as the conditions begin to change.

New design charts have been developed to evaluate the stability of the upper competent layers. These design charts will assist rock engineers to decide on which support mechanism to use in specific strata.

Analysis of the size of falls of ground which caused fatalities showed that a person is often killed by a relatively small piece of rock. Therefore, the stability of roof between the bolts was investigated. A new design chart is presented to evaluate the stability of the roof between roofbolts.

An investigation into how accurately mining dimensions are controlled in the underground environment was undertaken. The results indicated that there are instances of poor control of roadway widths. This as a critical parameter in roof support design.

Acknowledgements

The authors gratefully acknowledge co-operation given by many mines and funding from SIMRAC. The AMCOAL Rock Engineering Department is also gratefully acknowledged for allowing some of their sonic probe monitoring results to be included in this report.

Table of contents

	Page
Executive summary	2
Acknowledgement	3
List of contracted Enabling Outputs.....	6
List of Figures	7
List of Tables	12
1 Fall of ground accidents in South Africa collieries	13
1.1 Introduction	13
1.2 Investigation of fall of ground accidents	13
1.3 Conclusions	34
2 Literature survey of roof support design	38
2.1 Introduction	38
2.2 Roof support in South African collieries	38
2.3 Roof support design in the U.S.A.	56
2.4 Roof support design in Australia and UK.....	65
2.5 Conclusions	73
3 Underground monitoring of roof and support behaviour.....	74
3.1 Introduction	74
3.2 Underground monitoring procedure	75
3.3 Processing of information.....	76
3.4 Colliery 'A'	81
3.4.1 Site performance summary colliery 'A'	81
3.5 Colliery 'B'	82
3.5.1 Site performance summary colliery 'B'	97
3.6 Colliery 'C'	101
3.6.1 Site performance summary colliery 'C'	107
3.7 Colliery ' D '	107
3.7.1 Site performance summary colliery 'D' area one	112
3.7.2 Site performance summary colliery 'D' area two	120
3.7.3 Site performance summary colliery 'D' area three	124
3.8 Colliery ' E '	124
3.8.1 Site performance summary colliery 'E'	134
3.9 Analysis of underground field measurements	134
3.9.1 Time effects of a static face	138
3.9.2 Migration mechanism	138
3.9.3 Analysis of results of field measurements using numerical and analytical methods	146
3.10 Roadway widening	149
3.10.1 Instrumentation	149
3.10.2 Widening procedure	151

3.10.3	Results	154
3.10.4	Conclusions	159
3.11	Strain gauged roof bolt experiment	162
3.11.1	Installation	164
3.11.2	Interpretation of the results	165
3.11.3	Additional instrumentation results	168
3.11.4	Conclusions	169
4	New support design approach	170
4.1	Introduction	170
4.2	Determination of support mechanisms	170
4.3	Determination of stability of the immediate layer.....	174
4.4	Conclusions	180
5	Conclusions and recommendations for future research	181
5.1	Conclusions	181
5.2	Recommendations for future research	184
6	Reference	186
Appendix 1	Roof Stability system – Angus Place Colliery (After Butcher).....	189
Appendix 2	The sonic probe extensometer	192
Appendix 3	An introduction to the interpretation of sonic probe graphs	204

List of contracted Enabling Outputs

NO.	ENABLING OUTPUT	PAGES
1	Update fall of ground accident statistics.	13 - 37
2	Documentation of world wide roof support design methods.	38 - 73
3	Underground field trials to establish strata behaviour including the	74 - 134
	influence of road width.	
4	Analysis of results.	134 - 169
5	Optimisation of design.	170 - 180
6	Report on findings and suggested methodology.	184
7	Transfer of technology by workshops and training programmes.	184
8	Report.	1 - 213

List of Figures

	Page
Figure 1.1. Annual variation of the total number of fatalities and of the number of fatalities due to FOG accidents for the period 1989 - 1996	14
Figure 1.2. Number of fatalities for the period 1970 - 1996	15
Figure 1.3. Percentage of FOG/Total number fatalities for the period 1970 – 1996	16
Figure 1.4. Variation of the total number of injuries and those due to FOG accidents for the period 1989 - 1996	17
Figure 1.5. Percentage of FOG/total injuries for the period 1989 -1996	19
Figure 1.6. Causes of fatalities and injuries for the period 1989 - 1996.....	20
Figure 1.7. Underground labour for the period 1970 - 1996	21
Figure 1.8. FOG fatalities for per 1000 underground employees for the period 1970 to 1996	22
Figure 1.9. South African coal production for the period 1970 to 1996	23
Figure 1.10. FOG fatalities per 1000 tons of coal for the period 1970 to 1996	24
Figure 1.11. Percentage underground production and FOG fatalities for different coalfields for the period 1989 to 1996	26
Figure 1.12. Distribution of FOG fatalities between different collieries for the period 1989 to 1996	27
Figure 1.13. Comparison of FOG fatalities in South African coal mining and FOG and rockburst fatalities in South African gold mining industries	28
Figure 1.14. Distribution of fatalities with respect to mining layout	30
Figure 1.15. Distribution of fatalities with respect to job categories	30
Figure 1.16. Volume of FOG causing fatalities for the period 1970 - 1995.....	31
Figure 1.17. The vertical dimension (thickness) of FOG causing fatalities for the period 1989 – 1995	32
Figure 1.18. Distribution of fatalities with respect to experience in current job.....	33
Figure 1.19. Distribution of fatalities with respect to mine service experience	33

Figure 1.20. Distribution of fatalities with respect to permanent support	35
Figure 1.21. Distribution of fatalities with respect to temporary support	35
Figure 1.22. Distribution of fatalities with respect to geological discontinuities	36
Figure 1.23. Distribution of fatalities with respect to immediate roof	36
Figure 1.24. Distribution of fatalities with respect to accident location.....	37
Figure 1.25. Distribution of fatalities with respect to mining method	37
Figure 2.1. Basic roofbolt support mechanisms	38
Figure 2.2. Relationship between thickness of loose roof slab and number of bolts per unit area for bolts of 100, 150 and 200 kN failure load (After Wagner, 1985)	40
Figure 2.3. Bending stresses in roof slabs of different thickness for roadways of 5,6 and 7 m width (After Wagner, 1985)	42
Figure 2.4. Bolt pattern (After Spann and Napier, 1983)	43
Figure 2.5. Deflection compared to number of bolts (After Spann and Napier, 1983)	44
Figure 2.6. Design diagram for roofbolt systems based on control of shear deformations (After Wagner 1985)	44
Figure 2.7. Variation of the roof deflection measured (left) and of the elastic roof deflection calculated (right) in a roadway as a function of successive mining steps (After Vervoort, 1991)	46
Figure 2.8. Variation of the roof deflection measured (left) and of the elastic roof deflection calculated (right) in an intersection as a function of time (After Vervoort 1991)	46
Figure 2.9. Initial roof deflection (in mm) measured around the face during development of a roadway (After Vervoort and Jack, 1991)	47
Figure 2.10. Increase in roof deflection in three intersections during pillar extraction	48
Figure 2.11. Calculated roof deflection (in mm), occurring after mining step II, for various Young's modulus of the strata	48
Figure 2.12. Calculated roof deflection around the face during development of a roadway (Young's modulus of strata : 4 GPa)	49
Figure 2.13. Variation of roof deflection measured during pillar extraction across a panel	50
Figure 2.14. Cross section view of typical roof collapse in weak rock	55

Figure 2.15. Roof supported by bolting. (a) Supported. (b) Supported with fixed ends. (c) Supported from thick lamina. (d) Supported including thick lamina. (After Obert and Duvall, 1967)	57
Figure 2.16. Multiple (a), and single (b) lamina roof	60
Figure 2.17. Roofbolting design chart for friction effect (After Obert and Duvall, 1967)	61
Figure 2.18. Theoretical and idealized measured stress distribution around opening in gravity stress field ($\nu=0,25$) (After Obert and Duvall, 1967)	63
Figure 2.19. (a) Bolt normal to joint. (b) Bolt normal to surface (After Obert and Duvall, 1967)	64
Figure 2.20. Comparison of roof behaviour and stress distribution with different reinforcement practice (After Gale et. al.)	66
Figure 2.21. Summary of measured relationship between height of softening and roof displacement at different Australian collieries (After Gale et. al.)	67
Figure 2.22. Relationship between total roof displacement and stress magnitude at a given colliery (After Gale et. al.)	68
Figure 3.1. Graphic representation and explanation of a typical geological profile, support type and final roof strata behaviour	78
Figure 3.2. Colliery 'A' site 1 (roadway)	83
Figure 3.3. Colliery 'A' site 2 (roadway)	84
Figure 3.4. Colliery 'B' area 1 site 1 (intersection)	85
Figure 3.5. Colliery 'B' area 1 site 2 (roadway)	86
Figure 3.6. Colliery 'B' area 1 site 3 (roadway)	87
Figure 3.7. Colliery 'B' area 2 site 1 (intersection)	88
Figure 3.8. Colliery 'B' area 2 site 2 (roadway)	89
Figure 3.9. Colliery 'B' area 2 site 3 (roadway)	90
Figure 3.10. Beam deflection mechanism that could explain kickbacks close to the roof skin in sonic probe graphs	92
Figure 3.11. Comparison between shrinkage with time and parting closure with face advance	93
Figure 3.12. Colliery 'B' comparative roof behaviour	95

Figure 3.13. Disturbance in the roof between 2.5 m and 4.0 m elevations.....	96
Figure 3.14. Colliery 'B' comparison between roadway and intersection roof skin displacement	98
Figure 3.15. Colliery 'B' area 1 site 1 (intersection) collar anchor displacement	99
Figure 3.16. Colliery 'B' area 1 site 1 collar anchor velocity	100
Figure 3.17. Colliery 'C' site 1 (intersection)	102
Figure 3.18. Colliery 'C' site 2 (roadway)	103
Figure 3.19. Colliery 'C' site 3 (intersection)	104
Figure 3.20. Colliery 'C' site 4 (roadway)	105
Figure 3.21. Colliery 'C' comparative roof behaviour	106
Figure 3.22. Colliery 'D' area 1 site 1 (intersection)	108
Figure 3.23. Colliery 'D' area 1 site 2 (roadway)	109
Figure 3.24. Colliery 'D' area 1 site 3 (intersection)	110
Figure 3.25. Colliery 'D' area 1 site 4 (roadway)	111
Figure 3.26. Colliery 'D' area 1 comparative roof behaviour	113
Figure 3.27. Colliery 'D' area 1 comparison of roof skin displacement	114
Figure 3.28. Colliery 'D' area 2 site 1 (intersection)	116
Figure 3.29. Colliery 'D' area 2 site 2 (intersection)	117
Figure 3.30. Colliery 'D' area 2 site 3 (intersection)	118
Figure 3.31. Colliery 'D' area 2 site 4 (intersection holed into)	119
Figure 3.32. Colliery 'D' area 2 site 5 (roadway mining through dyke)	121
Figure 3.33. Colliery 'D' area 2 comparative roof behaviour	122
Figure 3.34. Colliery 'D' area 2 comparison between roadway and intersection roof skin displacement	123
Figure 3.35. Colliery 'D' area 3 site 1 (intersection)	125
Figure 3.36. Colliery 'D' area 3 site 2 (roadway)	126

Figure 3.37. Colliery 'D' area 3 site 3 (roadway blind end holed into)	127
Figure 3.38. Colliery 'D' area 3 comparative roof behaviour	128
Figure 3.39. Colliery 'E' site 1 (gate road)	129
Figure 3.40. Colliery 'E' site 2 (gate road)	130
Figure 3.41. Colliery 'E' site 3 (split between gate roads)	131
Figure 3.42. Colliery 'E' site 4 (gate road)	132
Figure 3.43. Colliery 'E' site 5 (roadway)	133
Figure 3.44. Colliery 'D' area 2 site 2 displacements	140
Figure 3.45. Mining method and comparative support performance at colliery 'D'	142
Figure 3.46. Effects of hole diameter increase on the cross sectional area of the hole and resin requirements using a 16 mm bolt and 22 mm drill bit	144
Figure 3.47. Effects of hole diameter on resin bond length using a 16 mm bolt and a 22 mm drill bit	145
Figure 3.48. Comparison of results obtained underground field trials and analytical method.....	147
Figure 3.49. Comparison of results obtained underground field trials and numerical modelling.....	148
Figure 3.50. Instrumentation layout	150
Figure 3.51. Roadway and adjacent intersections prior to widening	152
Figure 3.52. Cutting sequence and final roadway shape	153
Figure 3.53. Increase in roof deflection with widening of roadway	155
Figure 3.54. Roof behaviour of the 12 m widened roadway with time	156
Figure 3.55. Separation within the roof beam with time	157
Figure 3.56. Displacement rates as a function of time	158
Figure 3.57. Experiment site photographed on day nine.....	160
Figure 3.58. k-ratio at various depths in civil engineering tunnels.....	161
Figure 3.59. Remedial effect of additional active support (cable anchors)	163

Figure 3.60. Installation loads recorded and change in load with face advance	166
Figure 3.61. Change in loads with face advance and time	167
Figure 4.1. Support design evaluation chart for 5 m bord width	171
Figure 4.2. Support design evaluation chart for 6 m bord width	172
Figure 4.3. Support design evaluation chart for 7 m bord width	173
Figure 4.4. Design chart to determine the stability of roof strata between the bolts	175
Figure 4.5. Roofbolt pull-test results	176
Figure 4.6. Increase of the beam deflection, bending stresses and shear stresses with increasing bord widths	178
Figure 4.7. Bord width versus frequency	179

List of Tables

Table 1.1. Major causes for fatalities and injuries in South African coal mines	18
Table 1.2. Percentage of unknown information obtained from Inspector's reports	25
Table 1.3. Percentage of production and fatalities due to FOG versus mining method	29
Table 2.1. Unit and coal roof classification system (After Buddery and Oldroyd, 1989)	51
Table 2.2. Values of α for various N	62
Table 2.3. Values of C for various number of strata	62
Table 2.4. Different roof categories for Angus Place Colliery (After Butcher)	69
Table 3.1. Sonic probe, levelling and stable roof elevation results	77
Table 3.2. Sonic probe relaxation results adjusted to incorporate any applicable kickback values	135
Table 3.3. Total relaxation, kickback adjustments and stable roof elevation averages	137

1 Fall of ground accidents in South Africa collieries

1.1 Introduction

The Department of Minerals and Energy's Regional Offices at Braamfontein, Witbank, and Dundee were visited and the available fall of ground Inspector's reports were examined. The results showed that improved reporting of fall of ground (FOG) fatalities occurred during the period 1989 - 1995, although detailed information required for in-depth analysis was often not recorded. It was found that, during the period 1989 – 1996, 153 fatalities were due to falls of ground (SAMRASS).

Underground labour statistics were also obtained from the Department of Minerals and Energy (DME). The percentage production from underground, surface and from different South African coalfields was obtained by collation of data for individual collieries published in the annual DME report "Operating and developing coal mines in the Republic of South Africa" by extracting data published for each colliery. The data obtained for the period 1989 – 1996 were then compared with the data from Vervoort (1990) for the period 1970 – 1988.

1.2 Investigation of fall of ground accidents

Examination of all available documents from Inspector's reports on fall of ground fatalities for the period 1989 - 1996 was the basis of this project. This investigation showed that much relevant information was often not included in the reports reviewed. For example, in 70 per cent of the cases there was no mention of temporary support. Either temporary support was not required or it may have been installed but not mentioned during the inquiry. The information gathered by the review therefore cannot be taken as complete and reliable. Insufficient information was recorded in 40 per cent of the cases. The review thus highlighted what information should be routinely recorded and also what additional production type data is required which should be collated across the industry.

The data from SAMRASS (South African Mines Reportable Accident Statistics System) was used in this analysis.

Vervoort, 1990, investigated FOG fatalities for the period covering 1970 to 1988. The results from his investigation are compared with the results obtained from this project.

For the period 1989 - 1996, 417 fatalities were recorded in South African collieries, 153 of these were due to FOGs. The average number of fatalities per annum during the period 1970 - 1988 was 88. For the period 1989 - 1996 this figure was reduced to 52. The FOG component for these periods was 33 and 19 respectively (Figure 1.1 and 1.2), thus the average proportion of FOG fatalities to total fatalities remained almost constant at about 37 per cent, Figure 1.3. However figures for particularly years could be as high as 60 per cent or comprise only 18 per cent.

Some peaks in the total casualties in Figure 1.1 and 1.2 were due to major explosions and fires.

Figure 1.3 shows the percentage of FOG fatalities to the total number of fatalities for both periods 1970 – 1989 and 1989 – 1996. This figures highlights the fact that the percentage of FOG fatalities for the second period are, with some variation, similar to that obtained for the first period.

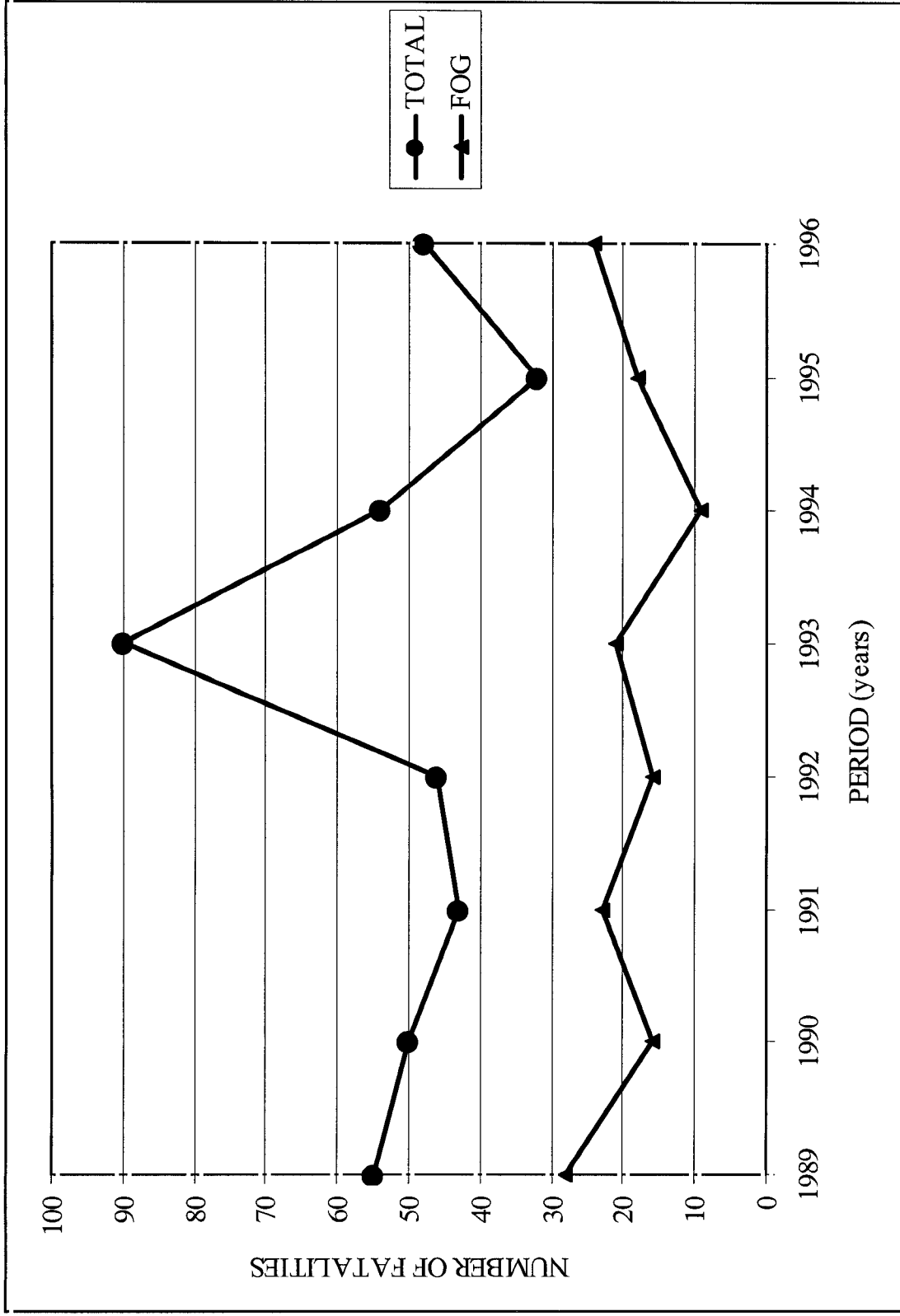

Figure 1.1. Annual variation of the total number of fatalities and of the number of fatalities due to FOG accidents for the period 1989 - 1996

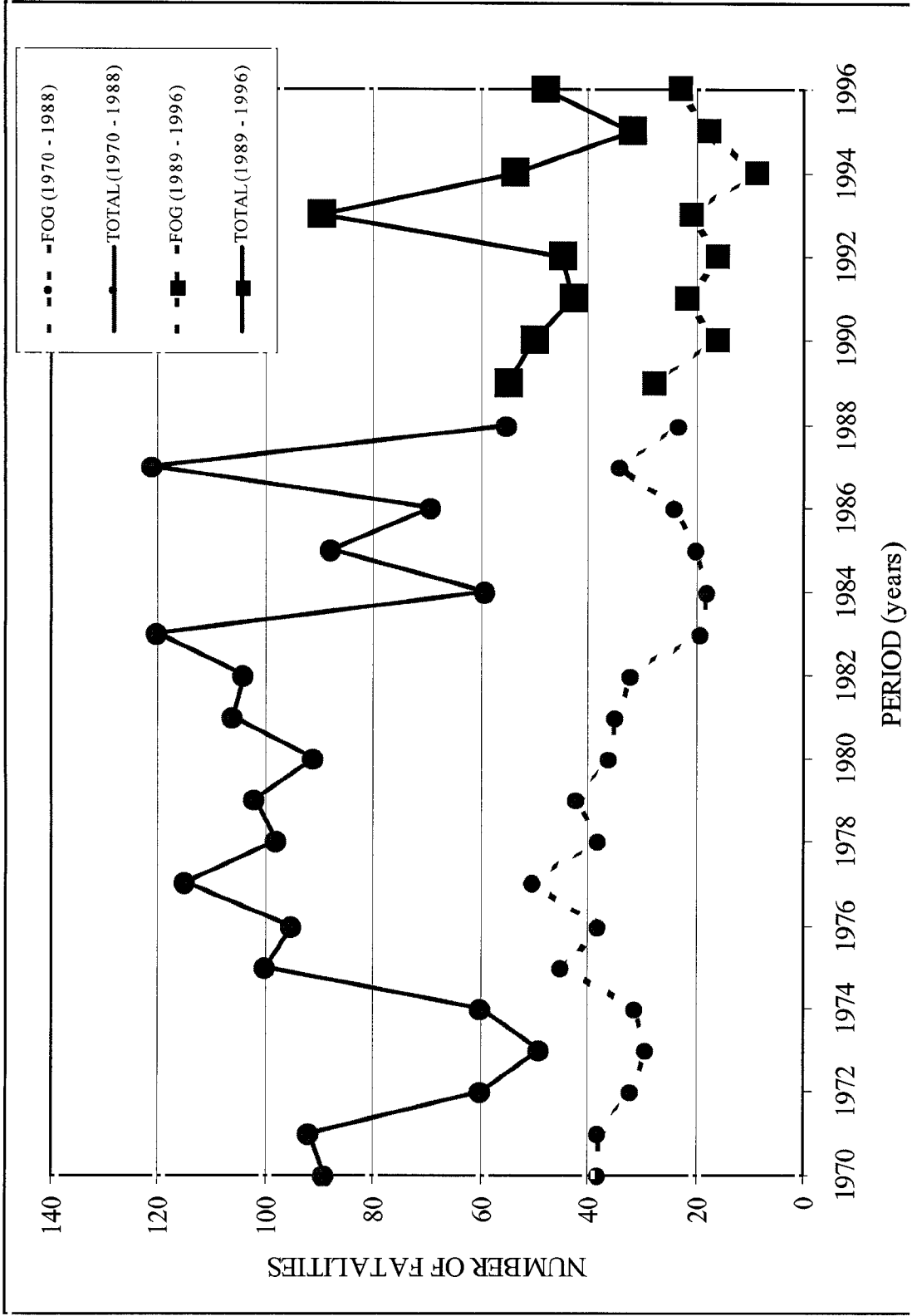

Figure 1.2. Number of fatalities for the period 1970 - 1996

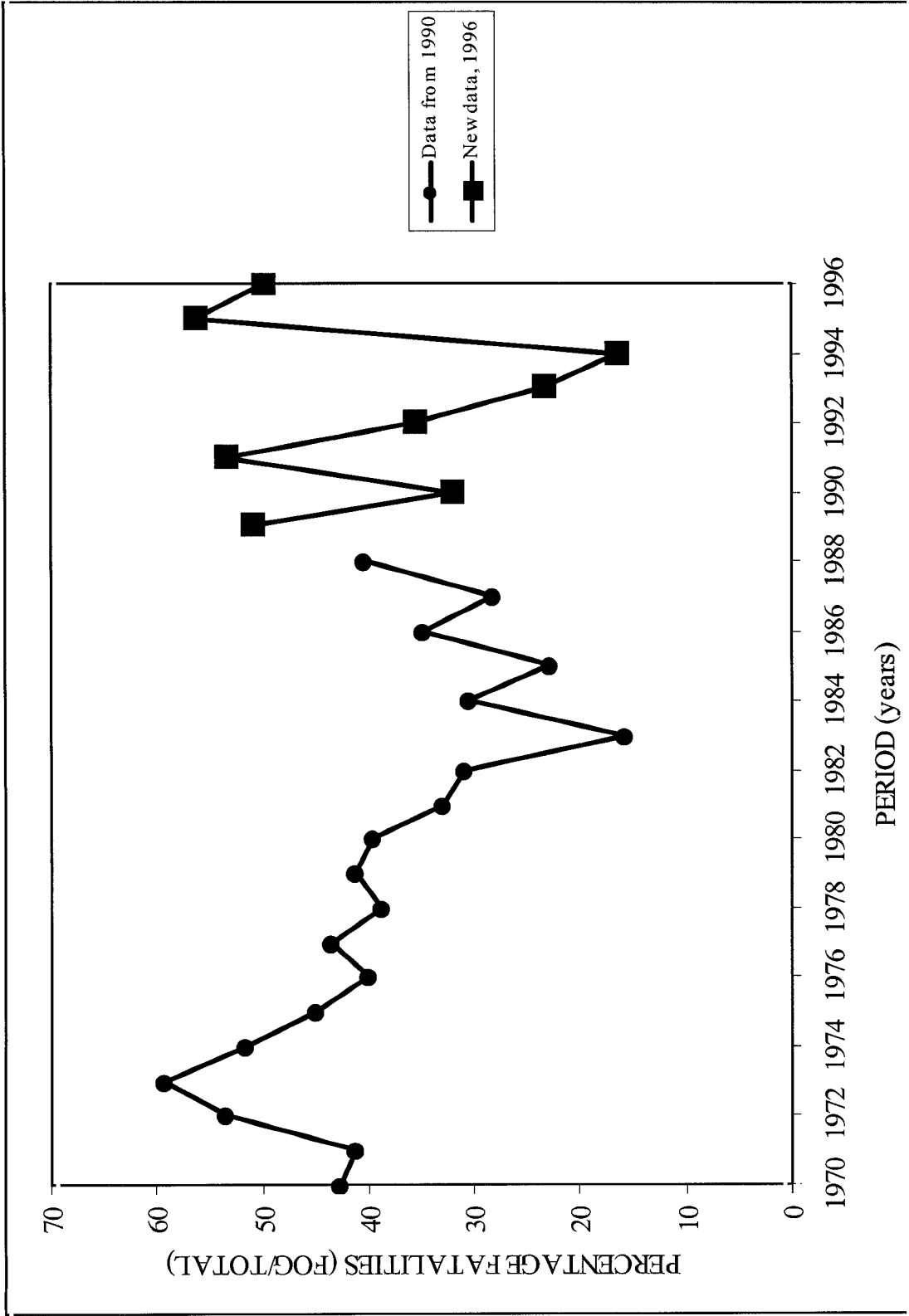

Figure 1.3. Percentage of FOG/Total number fatalities for the period 1970 – 1996

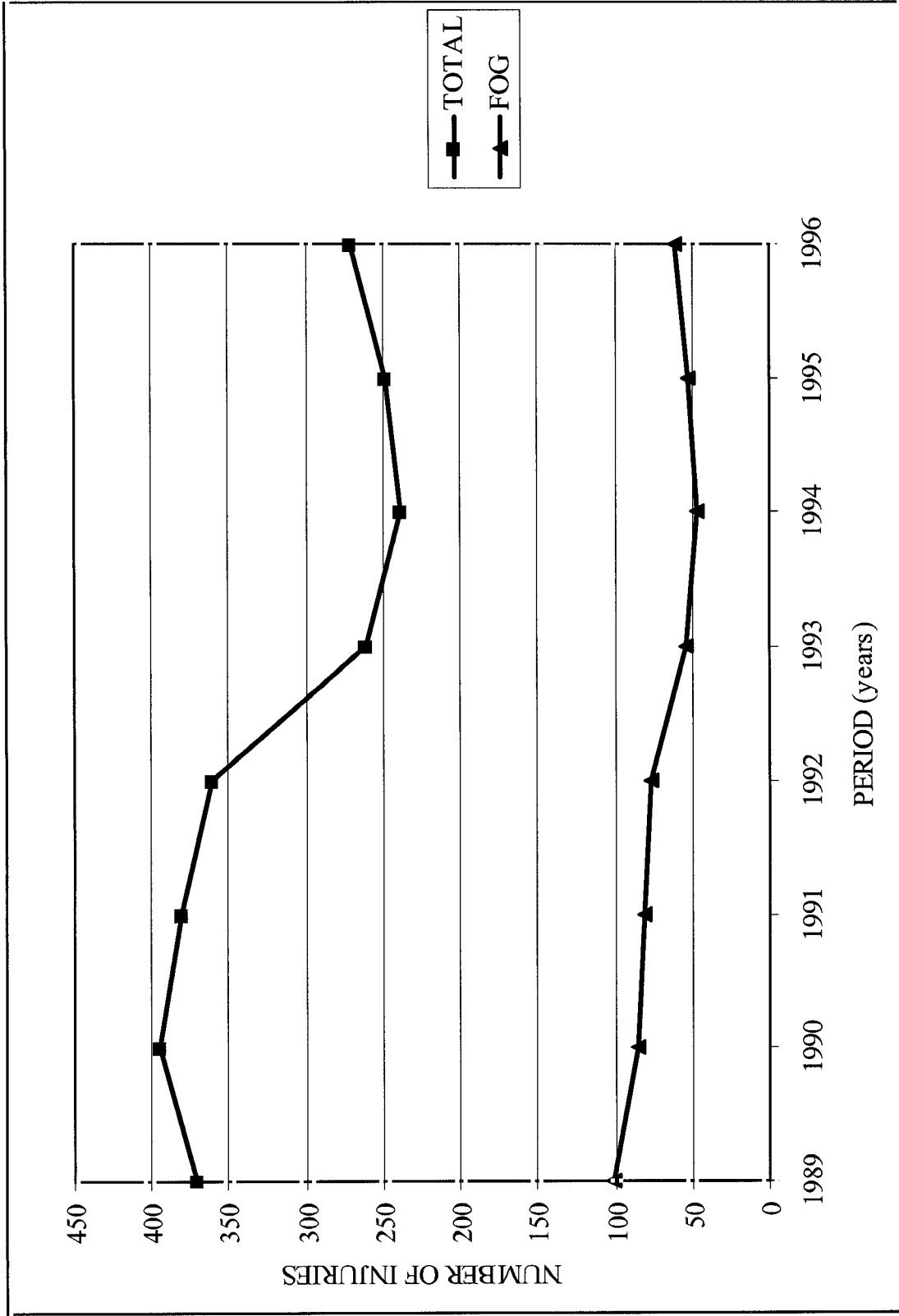

Figure 1.4. Variation of the total number of injuries and those due to FOG accidents for the period 1989 - 1996

In a second study reportable injuries were considered. During the period 1989 – 1996, a total of 2523 injuries were recorded of which 558 were due to FOGs, Figure 1.4. This gives an average of 70 FOG injuries per annum and a proportion of FOG to total injuries was 22.1 per cent, Figure 1.5. The proportion for the period 1970 - 1988 was 16 per cent thus showing an increase in recent years.

As can be seen from these figures FOG incidents have been the major cause of fatalities and injuries in the South African coal mining industry. Figure 1.6 shows the causes for fatalities and injuries for the period 1989 –1996. The data illustrated in Figure 1.6 is given in Table 1.1.

Table 1.1. Major causes for fatalities and injuries in South African coal mines

Causes	Fatalities (%)	Injuries (%)
Fall of ground	37.1	22.3
Free steered vehicle	16.5	16.9
Explosion/gassing	15.1	1.8
Mechanized handling	6.7	10
Fires	5.3	0.4
Machinery	4.5	9.7
Electricity	2.9	2.2
Falling/slipping	2.9	10.2
Falling material/rock	2.6	5.1
Inundation/drowning	1.7	0
Trackbound vehicle	1.7	0.8
Miscellaneous	1.4	3.7
Explosives	1.2	2.5
Manual handling	0.2	14.2
Rockburst	0.2	0
Shafts	0	0.3

Figure 1.2 showed that there is a slight decrease in the number of FOG fatalities per annum over the two periods. To analyse this further, the data was normalized to the number of underground personnel for the two periods. The number of underground employees is given in Figure 1.7. As can be seen from this figure, figures for underground labour increased from 1975 to 1988, but, after 1988, there has been a steady and significant decrease in labour from 55000 to 28000.

The FOG fatalities normalized per 1000 underground employees in service are given in Figure 1.8. Two distinct trends can be seen in this figure; - from 1970 to the 1980's and from the 1980's to 1995. The average rate for the latter period is approximately 0.5 compared to about 0.75 between 1970 and 1980. This decrease could be due to the introduction of continuous miners in South Africa. In 1996 the rate again reached a value equal to the highest values in the 1970's. These results indicate that the FOG risk to people going underground is reduced on average by about 35 per cent compared to the 1970's. However, in 1996 the risk increased again.

South African coal production data was also obtained from DME, Figure 1.9. This figure shows that the production has been significantly increased from 50 million to over 200 million tons over the years. The FOG fatalities normalized per 1000 tons of coal is given in Figure 1.10. This figure indicates that the risk of fatality involved in producing a ton of coal has been decreased by a factor of seven for the period 1970 to 1996.

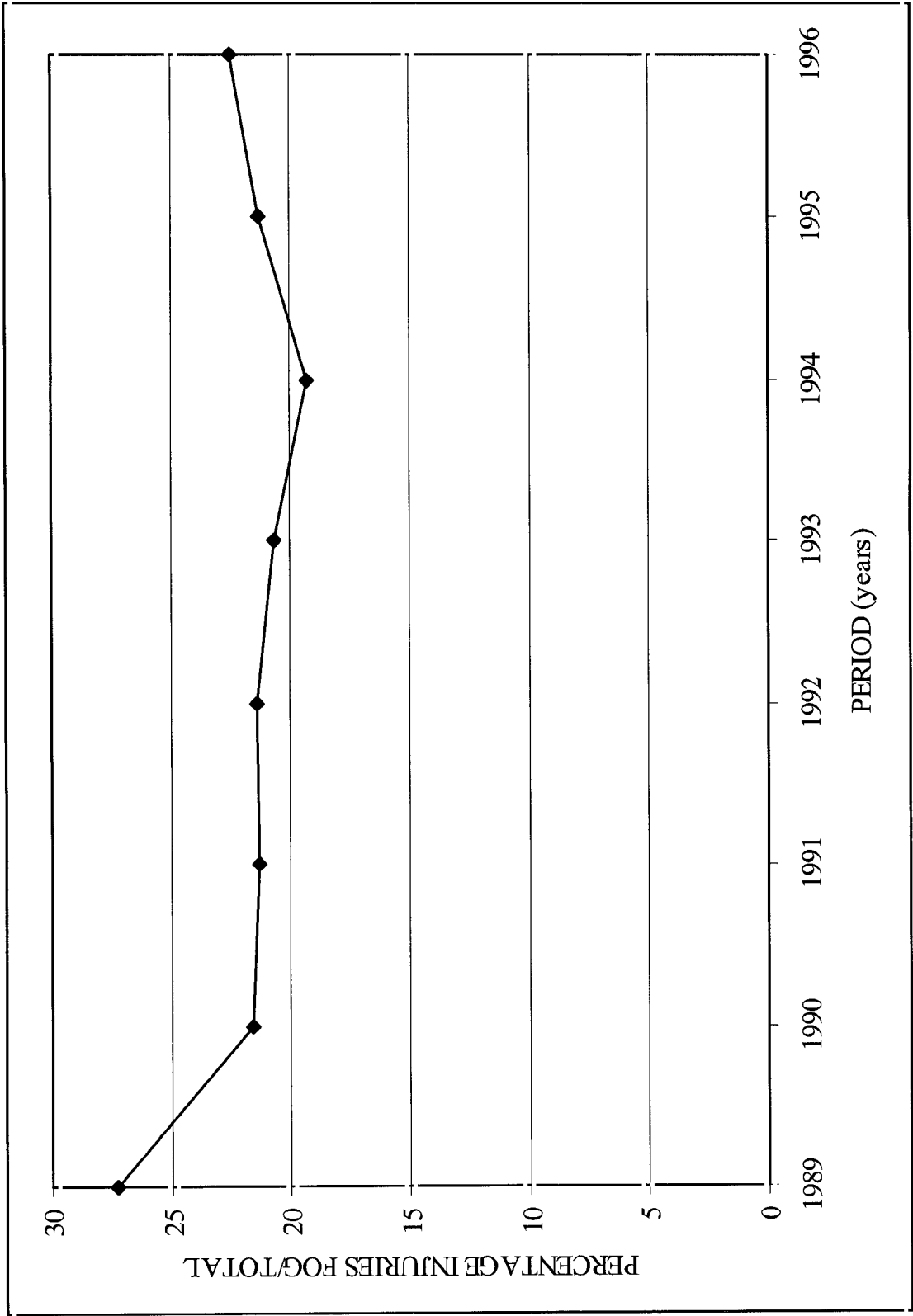

Figure 1.5. Percentage of FOG/total injuries for the period 1989 -1996

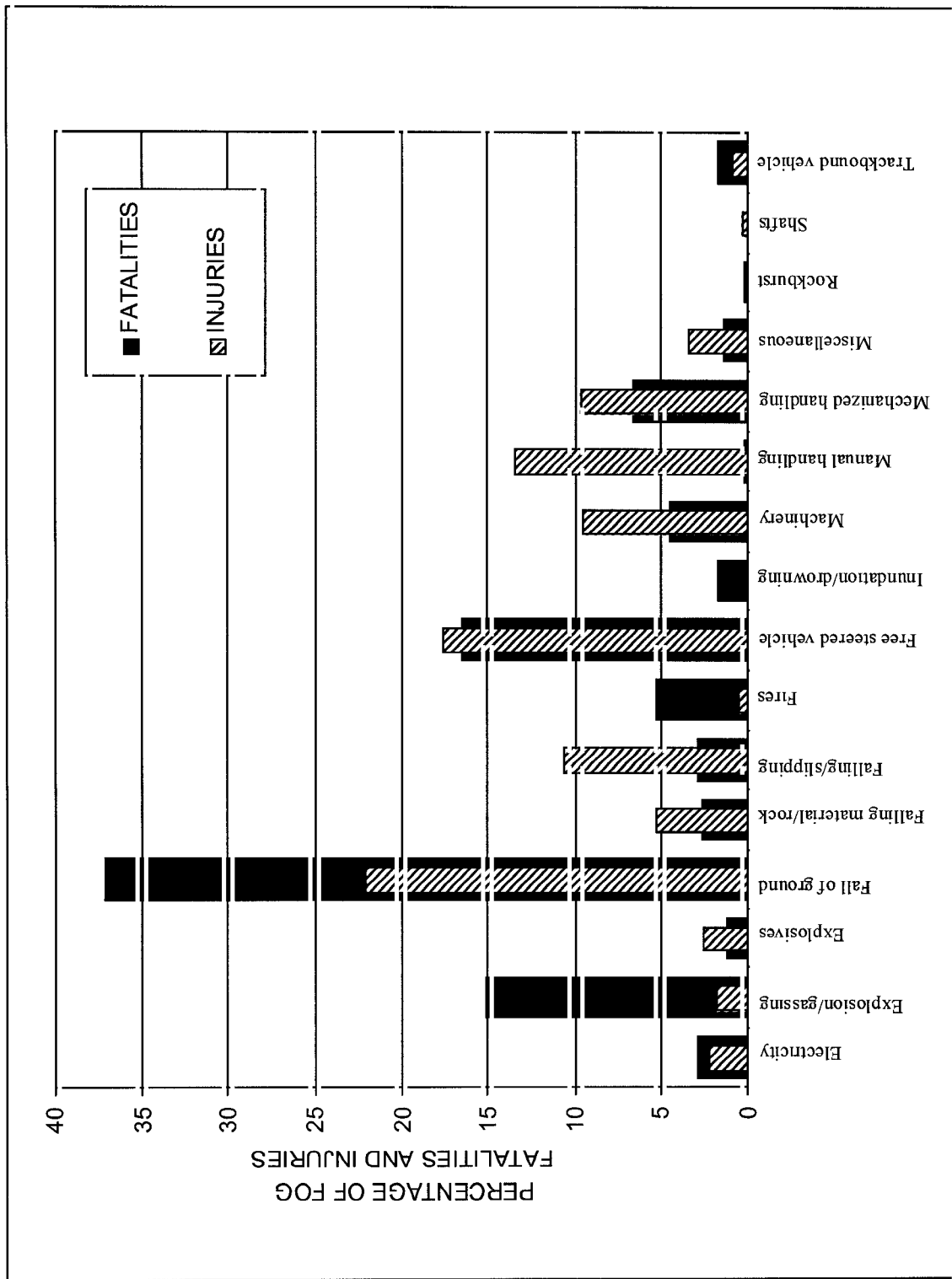

Figure 1.6. Causes of fatalities and injuries for the period 1989 - 1996

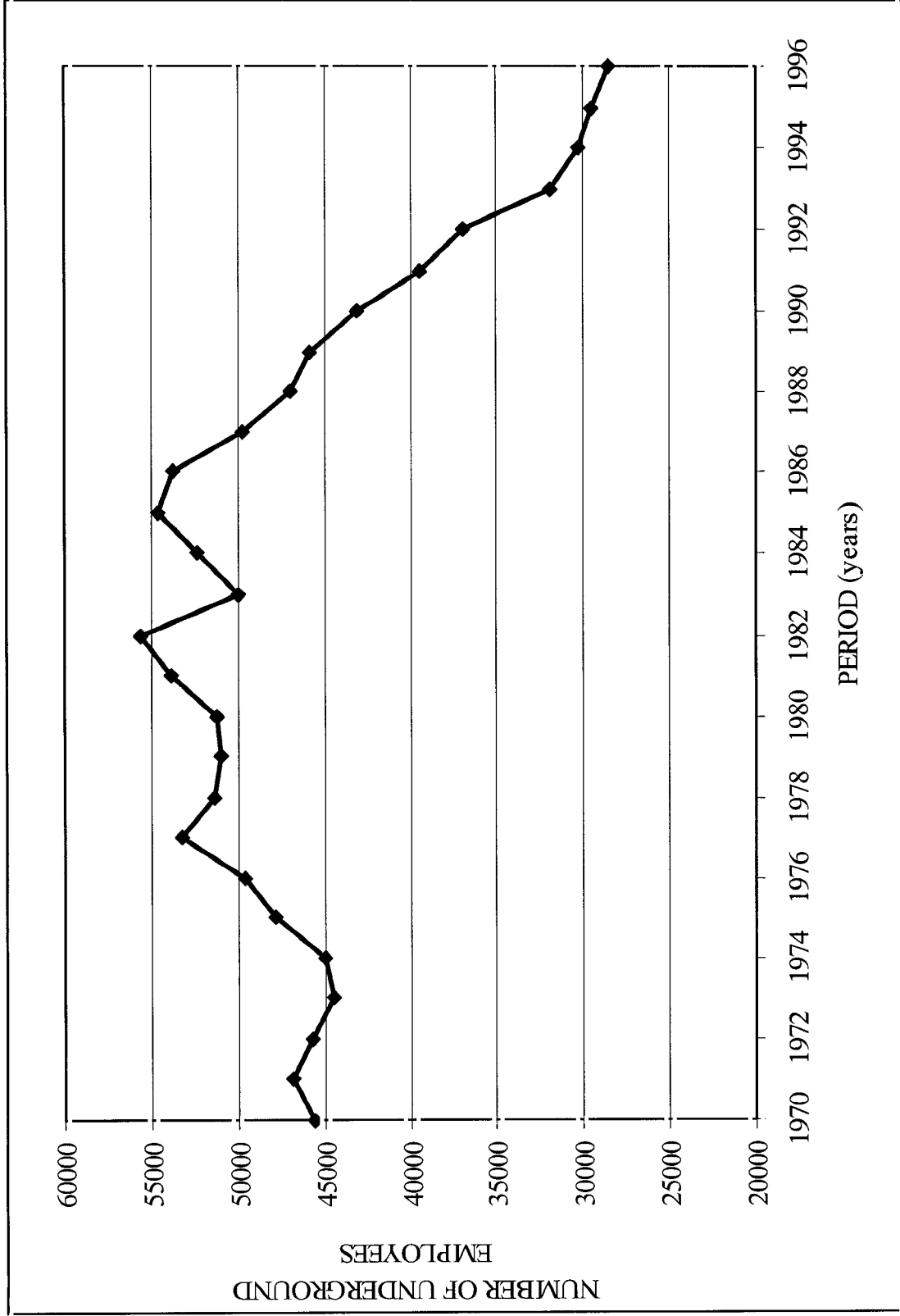

Figure 1.7. Underground labour for the period 1970 - 1996

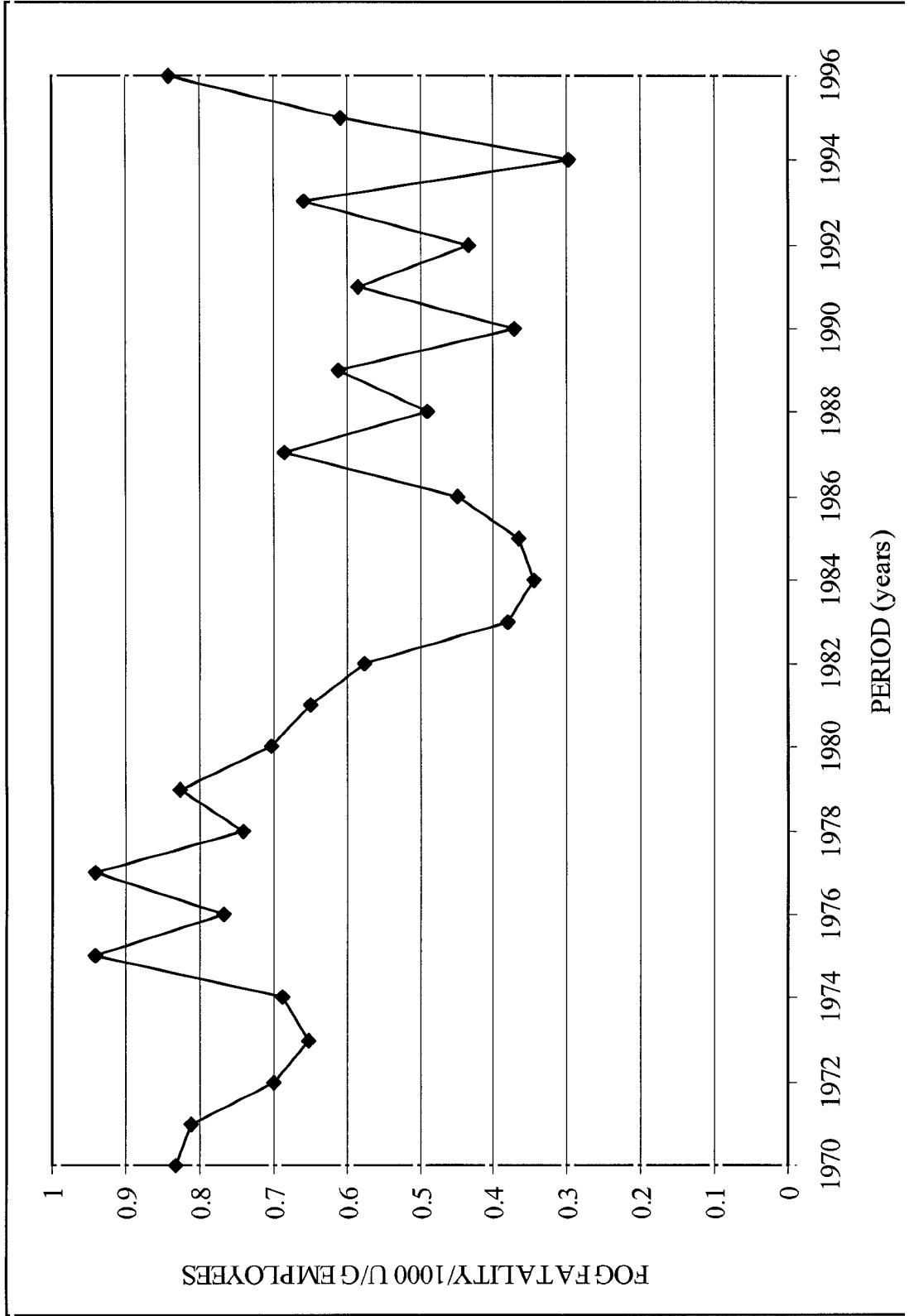

Figure 1.8. FOG fatalities for per 1000 underground employees for the period 1970 to 1996

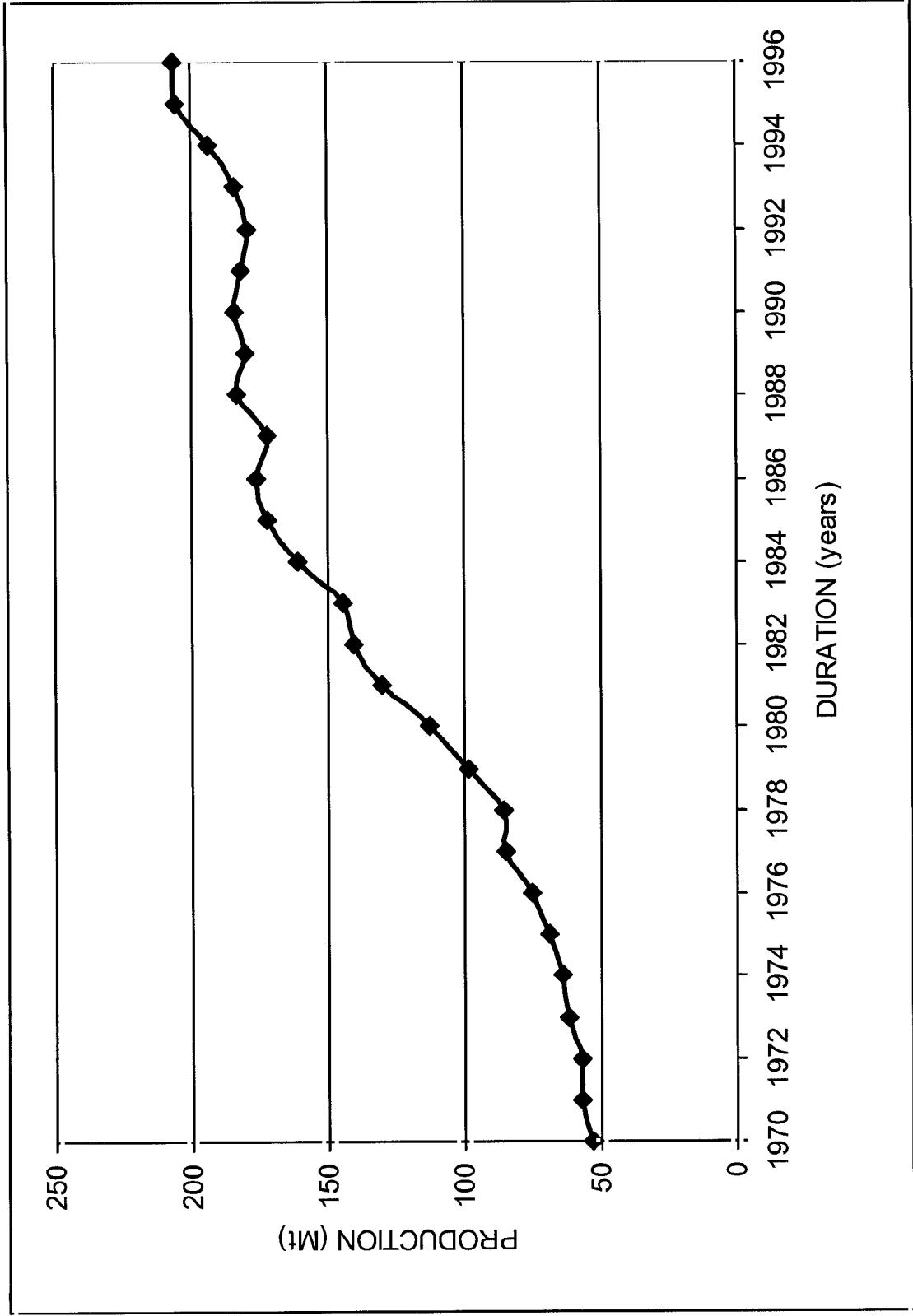

Figure 1.9. South African coal production for the period 1970 to 1996

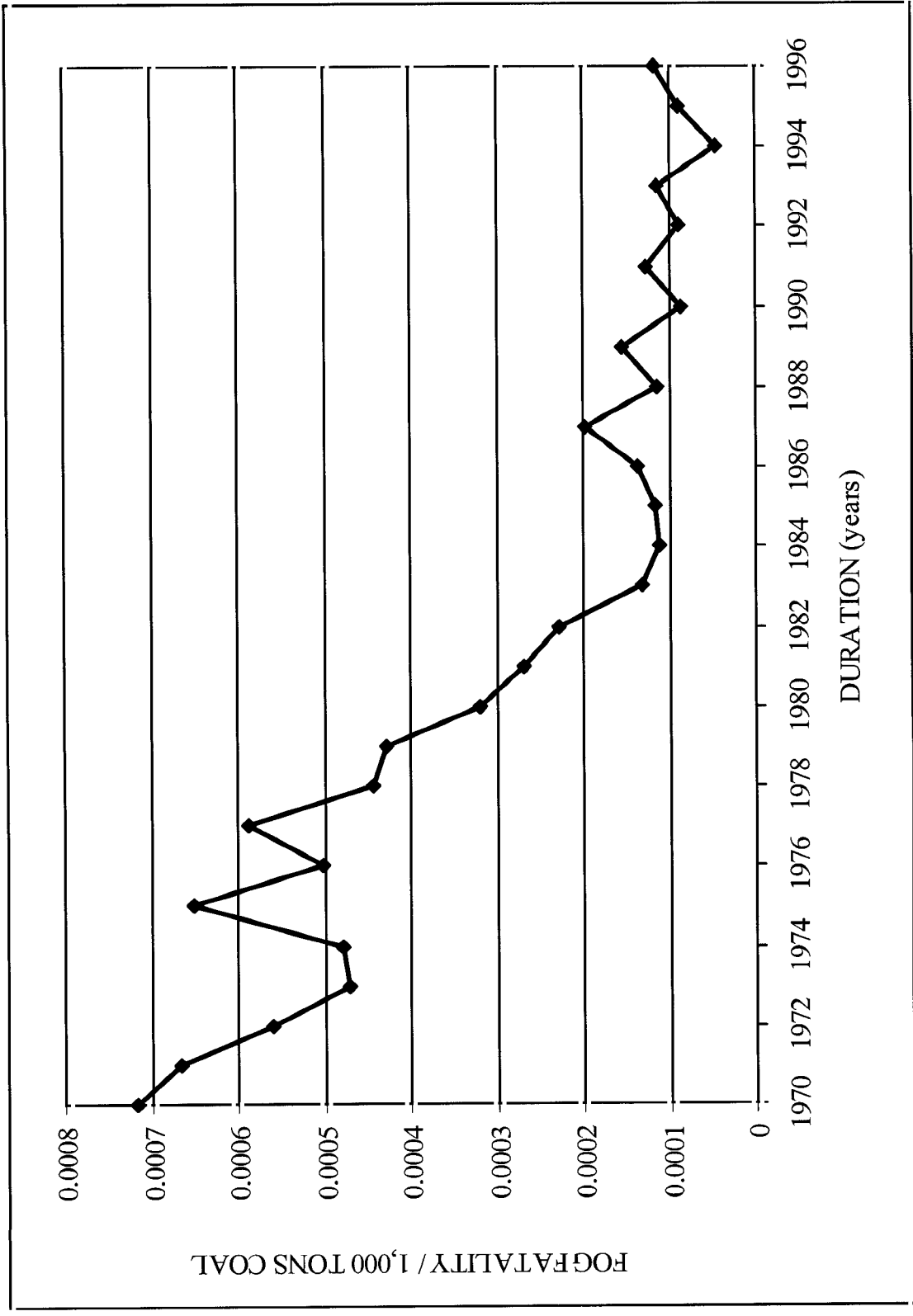

Figure 1.10. FOG fatalities per 1000 tons of coal for the period 1970 to 1996

The percentage production figures for underground, surface and individual South African coalfields were obtained from the DME's publication "Operating and developing coal mines in the Republic of South Africa" by collating the data from all the collieries.

Figure 1.11 shows the FOG fatalities together with the underground production figures for 11 coalfields in South Africa. This figure shows that, while the Witbank Coalfield produces 45 per cent of the coal, the FOG fatalities comprise only 22.5 per cent of the total. At the other extreme are the Vryheid and Klip River Coalfields, where the percentage production is significantly lower than the percentage FOG fatalities. The approximate 30 per cent of all fatalities, which occur in these areas due to FOGs is a matter of concern, which requires urgent attention. The root cause of these FOG incidents needs to be determined as a priority.

How FOG fatalities are distributed between different collieries is illustrated in Figure 1.12. This figure is based on the eight years between 1989 and 1996 and the relative distribution of all the categories is presented. Forty-eight per cent or 46 collieries had no fatal FOG accidents during this eight year period. At the other extreme is one colliery which had 23 fatalities. This shows that all the fatalities during the period 1989 – 1996 occurred on only 54 per cent of the collieries and that a significant proportion operated for eight years without a fatality.

For comparison, the fall of ground fatalities normalized per 1000 underground employees in collieries was compared to the fall of ground and rockburst fatalities normalized per 1000 underground employees in South African gold mines. This data was available only for the period covering 1988 to 1996. The results are shown in Figure 1.13. As can be seen, the risk of being killed in a FOG incident to individuals going underground on coal mines was higher for four years, equal for three years and only lower for two years than for personnel on gold mines.

Only 99 fatality reports out of 130 were available at the DME's offices for detailed review for the period covering 1989 to 1995. Nevertheless, this available information was also analysed to identify and indicate priorities for future research. The percentage of cases where information was not recorded, with respect to mining layout, dimension of fall, job categories, experience in current job, mine service experience, temporary support, permanent support, geological discontinuities, immediate roof, accident location and mining method, is given in Table 1.2.

Table 1.2. Percentage of unknown information obtained from Inspector's reports

Broad Category	Percentage
Mining layout	37
Dimension of fall	29
Job categories	2
Experience in current job	21
Mine service experience	37
Temporary support	70
Permanent support	48
Geological discontinuities	50
Immediate roof	45
Accident location	25
Mining method	42

This indicates deficiencies in the way accident data are recorded and was one of the main reasons for the initiative to introduce a new accident data reporting form. The initial version of this new fall of ground accident form was used to collate the information collected in the 1989 - 1995 inspector's reports.

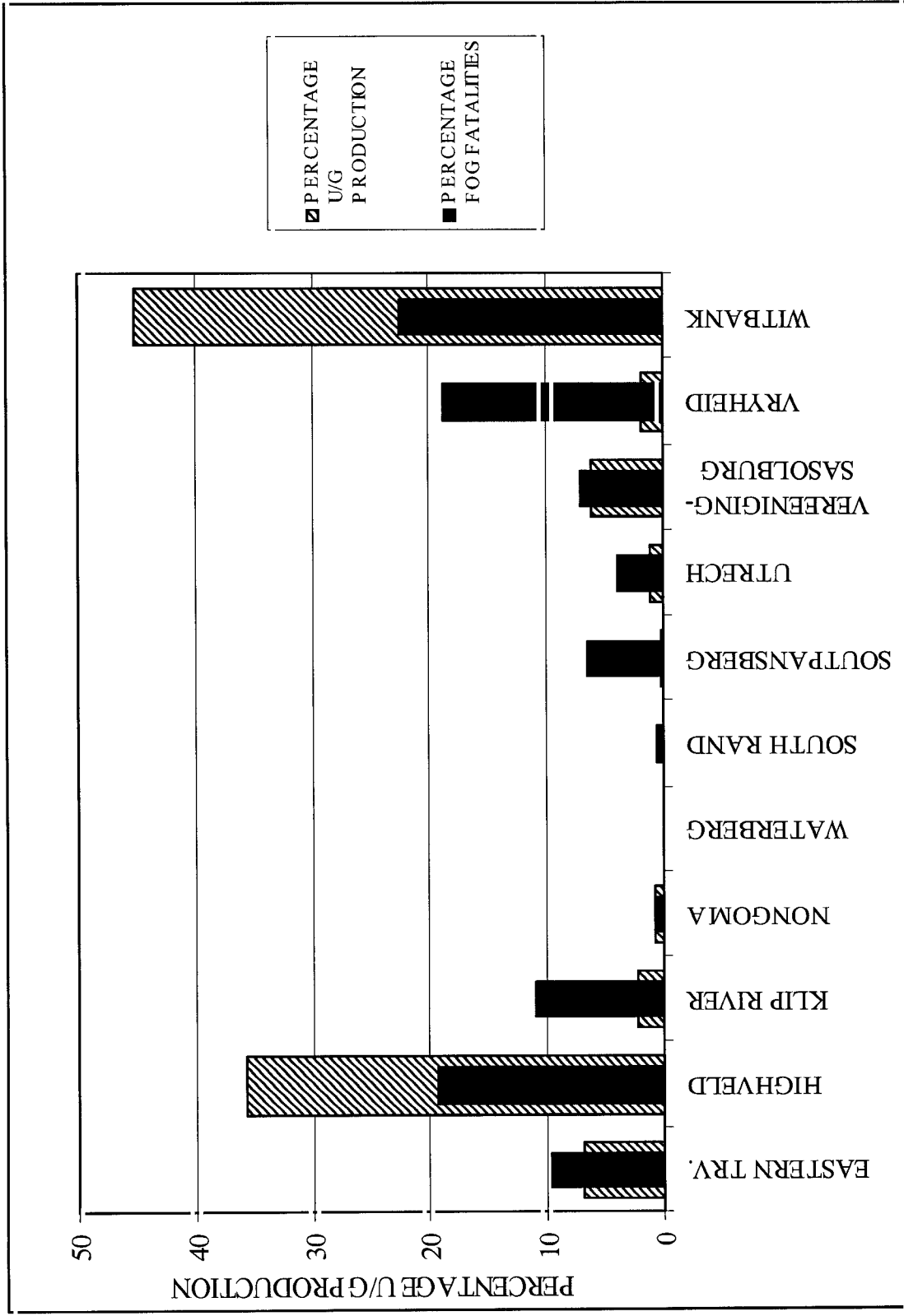

Figure 1.11. Percentage underground production and FOG fatalities for different coalfields for the period 1989 to 1996

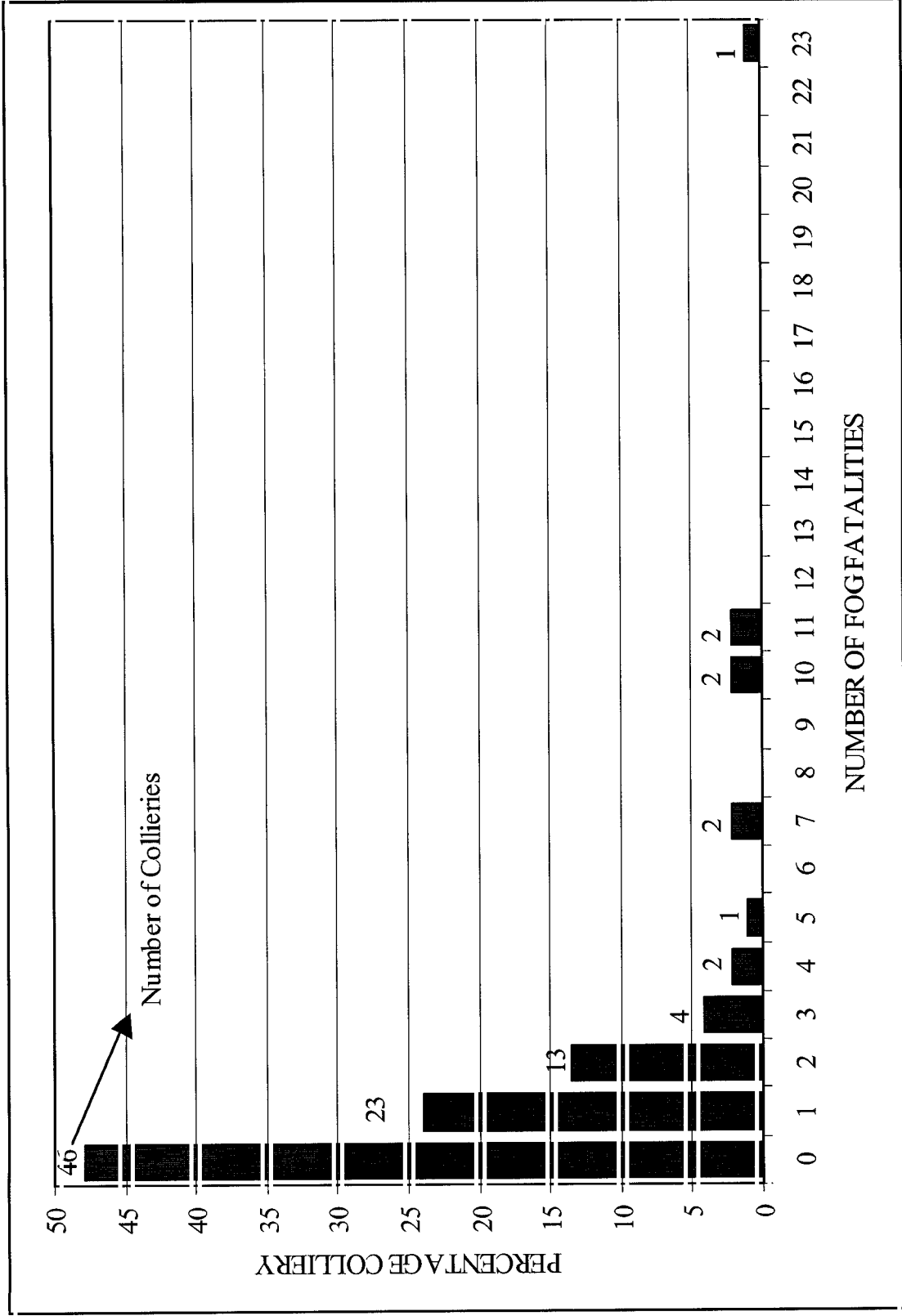

Figure 1.12. Distribution of FOG fatalities between different collieries for the period 1989 to 1996

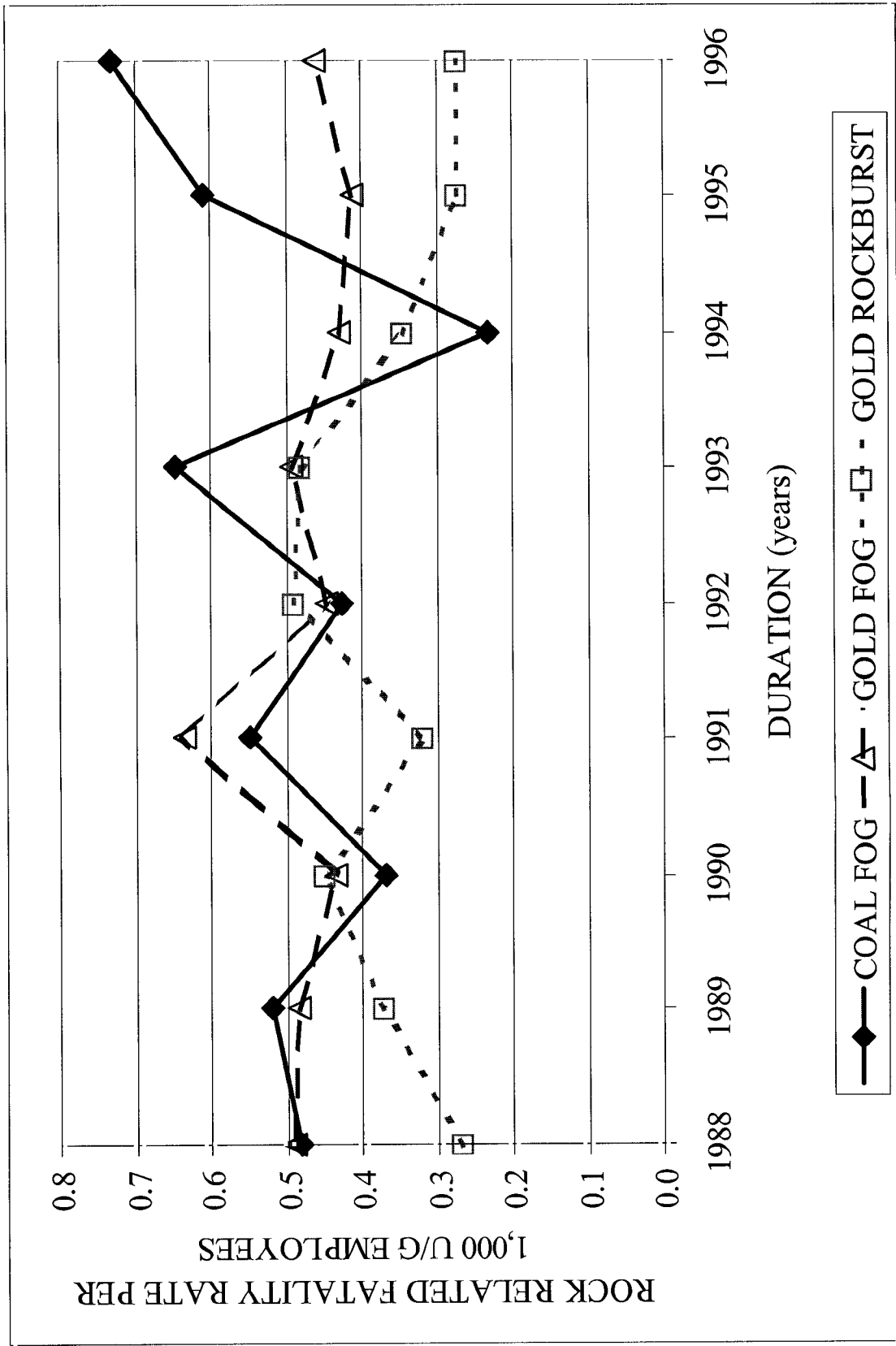

Figure 1.13. Comparison of FOG fatalities in South African coal mining and FOG and rockburst fatalities in South African gold mining industries.

Figure 1.14 shows that some 36,5 per cent of fall of ground accidents occurred in pillar extraction sections. For meaningful analysis the percentage of production or personnel involved in the different types of mining should be known. Unfortunately this information was not readily available and thus the casualty data could not be normalized.

Information for 1994 and 1995 regarding production figures from bord and pillar, stooping and longwall sections was compared to the fall of ground fatalities in these categories and are shown in Table 1.3.

The low number of fatalities, six and 11 in these years respectively, can result in large variations from year to year. However, the indication that stooping has a higher fatality rate than other methods of mining is corroborated by the study covering the period 1985 - 1988, Vervoort (1990), who gave the percentages 12.7% of all saleable coal coming from stooping sections and, in the same period, 28.3% of fatal accidents occurring in these sections.

Table 1.3. Percentage of production and fatalities due to FOG versus mining method

Mining	1994			1995		
	Production	Fatalities	No	Production	Fatalities	No
Stooping	24.0 %	50.0 %	3	18.5 %	63.6 %	7
Bord and Pillar	67.0 %	33.3 %	2	70.7 %	36.4 %	4
Longwall	9.0 %	16.7 %	1	10.9 %	0.0 %	-

Figure 1.15 gives fatalities with respect to job categories. In only two per cent of Inspector's reports were the job categories not mentioned. From this graph it can be seen that drill operators are at a higher risk compared to other job categories. If all machine operator, cable handler and roof bolt and drill operator fatalities are included in a single category, then it is seen that this comprises 63.3 per cent of all fatalities. This indicates that, during the period 1989 - 1990, more people were killed working at the face than any other job categories. Again, for meaningful analysis, the percentage of manning or personnel involved in different types of mining should be known. Unfortunately, this information was not available, therefore the data could not be normalized.

Vervoort (1990) stated that a person is often killed by a relatively small piece of rock which fell from between the roofbolts. Figure 1.16 shows the comparison of two data sets with respect to volume of fall. This shows that, for both periods, a large proportion of fall of ground accidents was due to relatively small falls of ground. However, the proportion of larger falls of ground has increased in the recent data. In these analyses, the volume was estimated based on the measured dimensions. As no information was available on the shape of the cavity, it was assumed that the cavity is a rectangular block; the real volume is thus equal to or less than that estimated. Similarly Figure 1.17 shows that a large number of FOG fatalities (63.3 per cent) was due to relatively thin falls of ground (64 per cent less than 0.5 m thick) for the period 1989 - 1995. These results confirm with Vervoort's (1990) findings and indicate deficiencies in areal coverage or roofbolt spacing, rather than length or strength.

Figures 1.18 and 1.19 show the distribution of fatalities with respect to experience in current job and mine service respectively. During the period 1989 to 1995, most of the miners (60.8 per cent) killed due to FOG accidents had less than two years experience in their current job. However, 36.5 per cent of the victims had less than two years experience on the mines. These graphs show that, while the lesser experienced (less than two years) workers appear to be at higher risk, experience is no guarantee of safety. These results highlight the importance of training, both in the fundamentals of hazard recognition and basic strata control, for new recruits, particularly for experienced people moved from one type of job to another. Here the different hazards associated with the new work environment need to be emphasised and consequences of not doing a job properly explained.

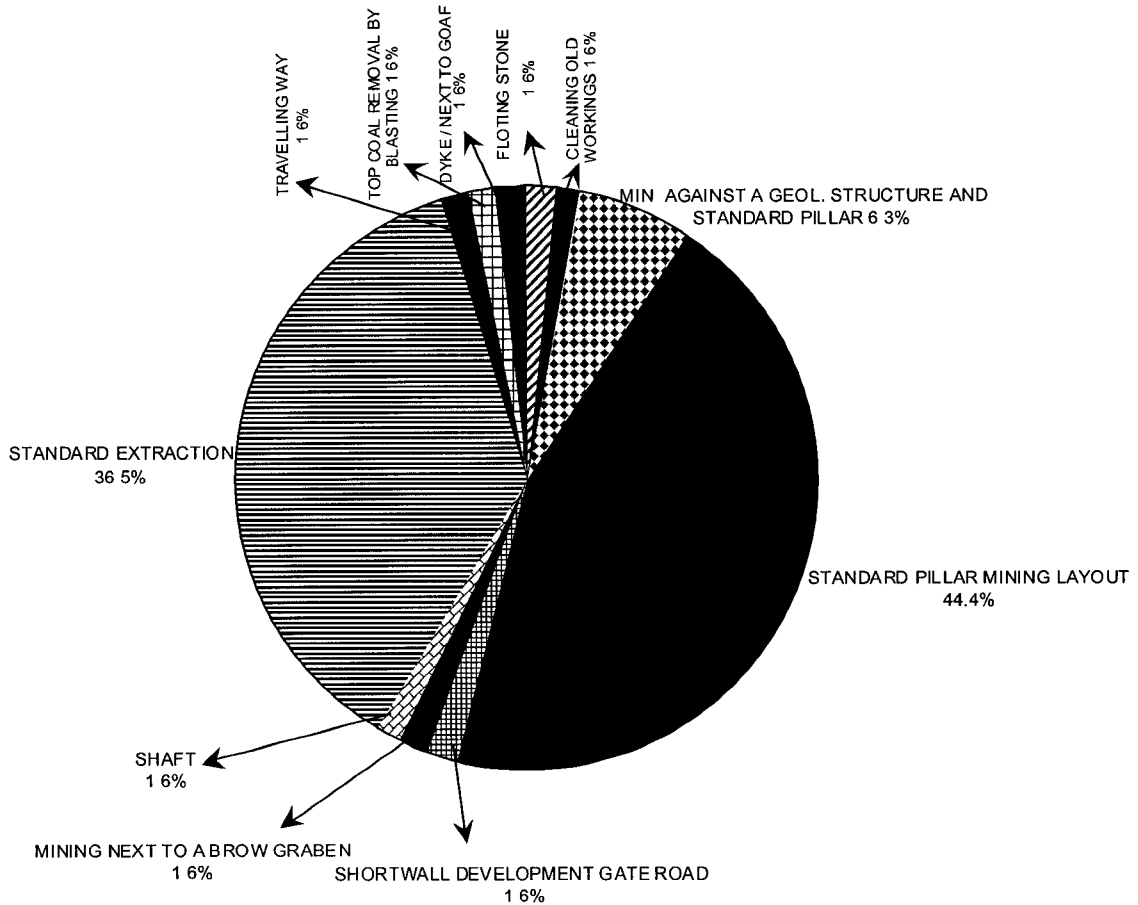

Figure 1.14. Distribution of fatalities with respect to mining layout

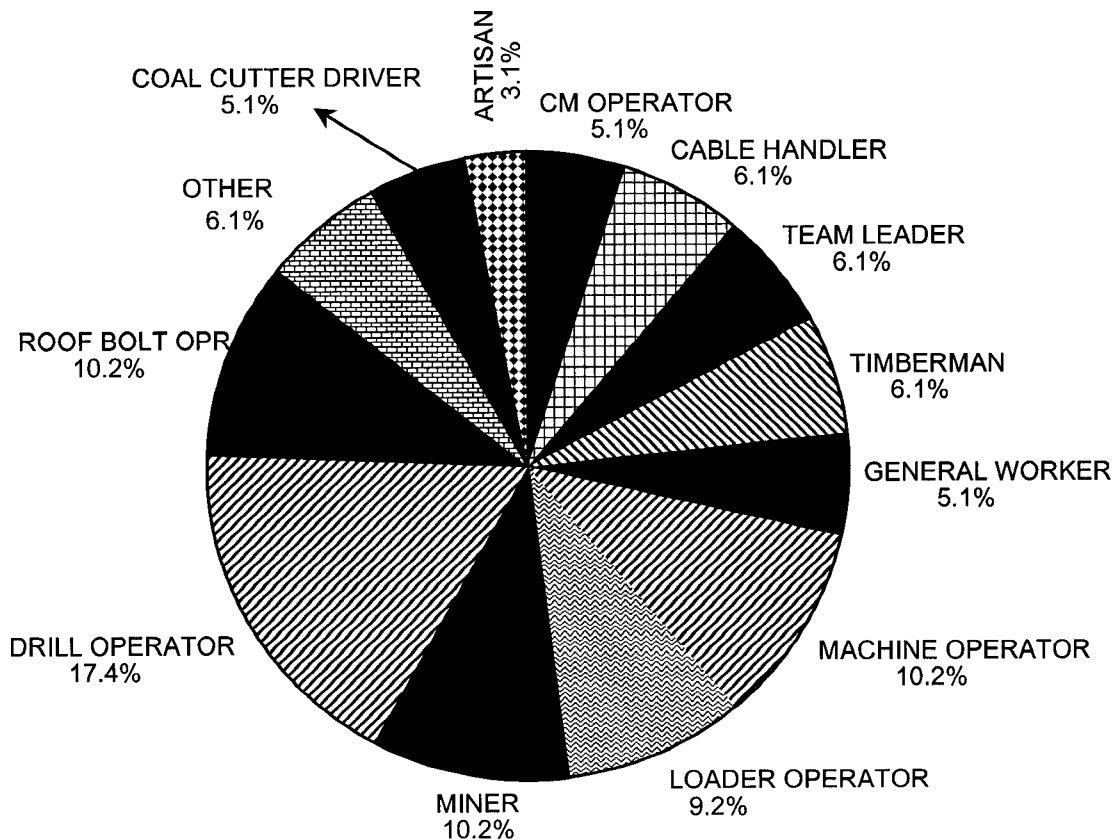

Figure 1.15. Distribution of fatalities with respect to job categories

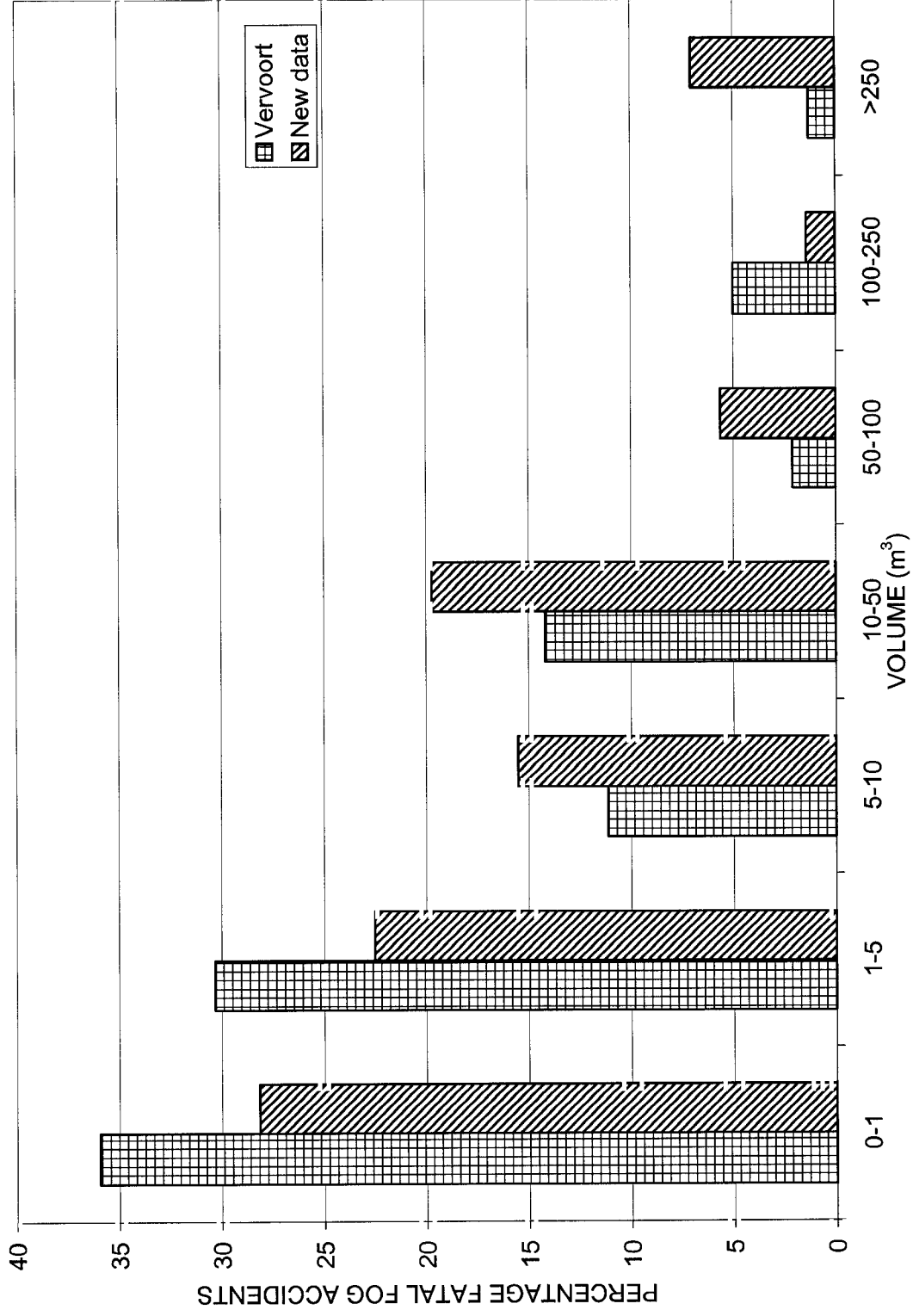

Figure 1.16. Volume of FOG causing fatalities for the period 1970 - 1995

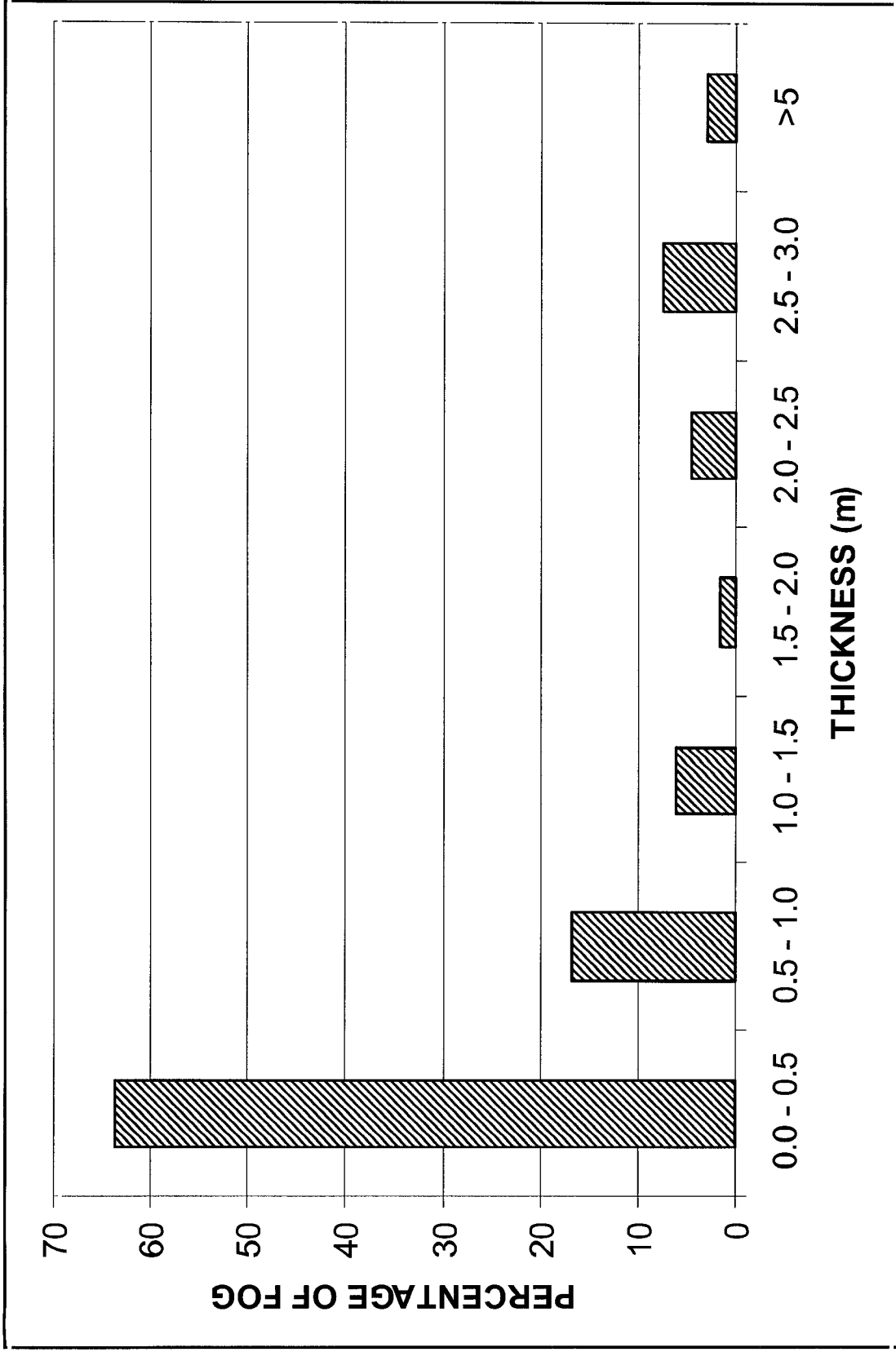

Figure 1.17. The vertical dimension (thickness) of FOG causing fatalities for the period 1989 - 1995

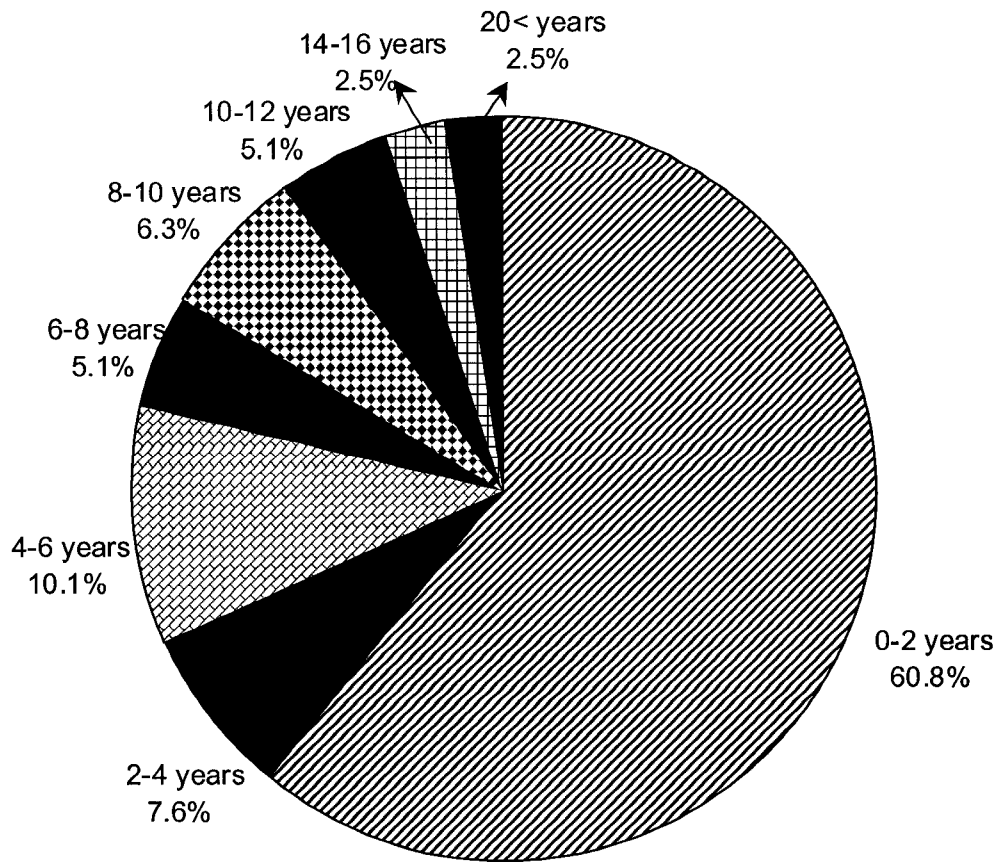

Figure 1.18. Distribution of fatalities with respect to experience in current job

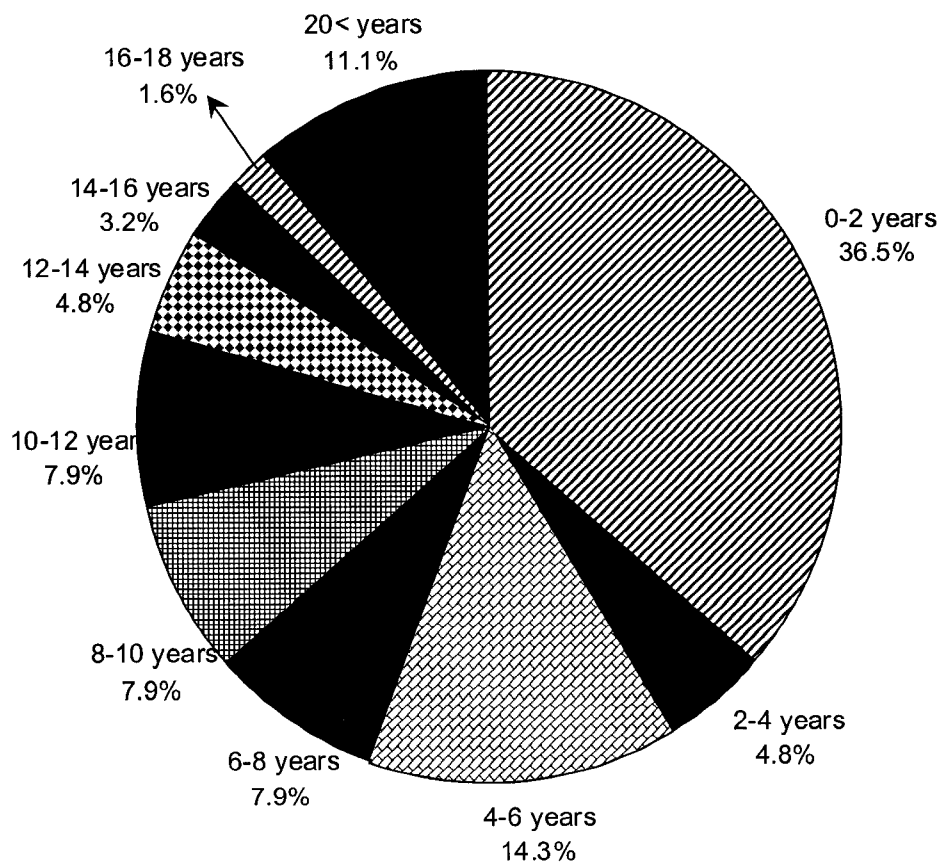

Figure 1.19. Distribution of fatalities with respect to mine service experience

Figures 1.20 to 1.25 show the information obtained from the inspector's reports for permanent support, temporary support, geological discontinuities, immediate roof, accident location and mining method. As mentioned earlier, a large portion of the information was missing in the inspector's reports, therefore the information gathered and shown in these figures cannot be taken as complete and reliable. It is again noted that industry wide data for the proportions of all the factors covered in Figures 1.20 - 1.25 is not available and thus normalization of the information to improve its relevance and usefulness could not be carried out.

1.3 Conclusions

Analyses of accident reports showed that, while the number of FOG fatalities decreased on average for the period 1989 – 1996 compared to the period 1970 – 1989, the proportion of FOG injuries to total injuries increased from 16 to 22 per cent for the period covering 1989 - 1996. Also, the results showed that FOG accidents still remain the largest single cause of fatalities and injuries in South African collieries.

The risk of a fatality being involved in producing a ton of coal has been decreased by a factor of seven over the years, due to a significant increase in production and a decrease number of underground employees. However, the risk to the individuals going underground has not shown a significant increase or decrease over the 27 year period.

The results indicated that all the fatalities occurred on 54 per cent of the collieries, while 46 per cent were fatality free for the eight year period 1989 – 1996. The size of the individual collieries was however not taken into account

Similarly, the ratio of percentage FOG fatalities to percentage coal production was excessively high in some coalfields. This highlights an issue which requires urgent attention in these coalfields.

Analysis of accidents to identify future areas for research showed that improved reporting of FOG fatalities is required and that data to normalize various aspects of accidents needs to be routinely collected industry-wide.

However, the following observations are made.

- The effectiveness of roofbolt design and its implementation needs to be improved.
- During the period 1989 - 1995, a large number of FOG fatalities (63.3 per cent) was due to relatively thin falls of ground between the roofbolts.
- Seventeen per cent of fatalities occurred where no temporary support was installed.
- Slips, joints and faults were associated with more than 50 per cent of fatalities. This compares with 20 per cent caused by failure on bedding planes. Support design to improve stability in the presence of joints needs to be investigated.
- Training is indicated as an important factor in preventing FOG fatalities, and the personnel working at the face are at a higher risk than the other job categories. Therefore, improved training programmes for people working at the face and supervisors should reduce FOG fatalities.
- The high proportion of fatalities associated with sandstone roofs, 33 per cent, is perhaps surprising as this type of roof is generally considered to be stable. The reasons for this need to be determined.
- While 60.7 per cent of the FOG fatalities occurred in intersections and roadways, 25.3 per cent occurred at the face.
- The stooping method is indicated as the most dangerous exploitation method with regard to falls of ground in South African collieries.

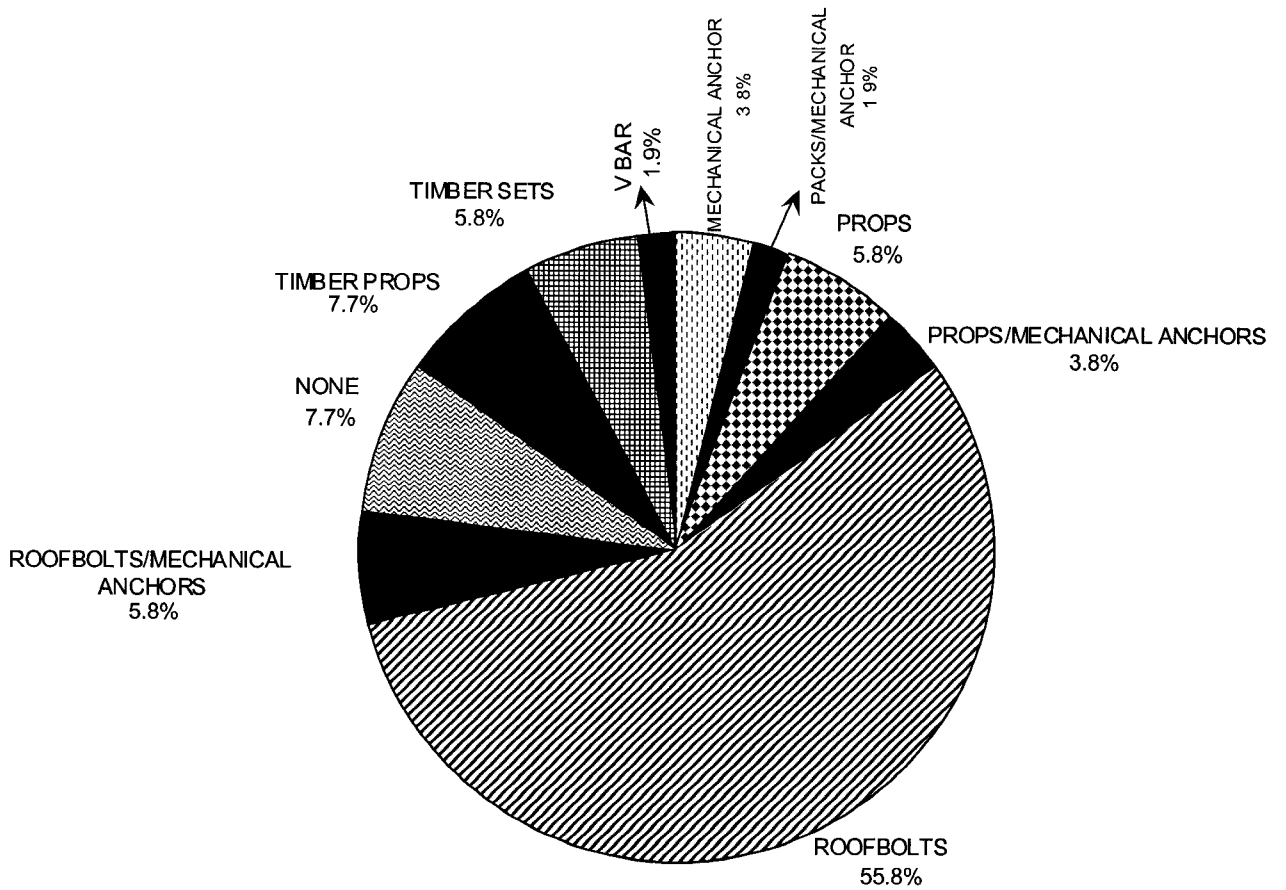

Figure 1.20. Distribution of fatalities with respect to permanent support

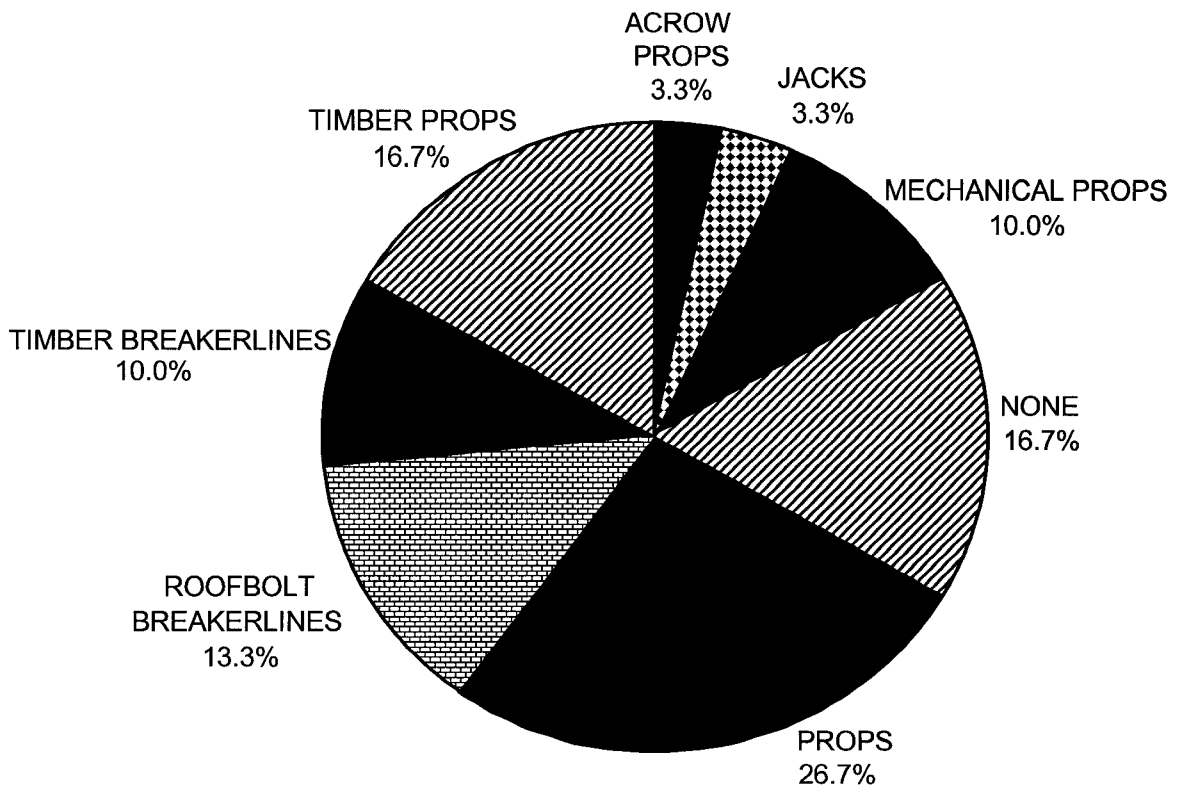

Figure 1.21. Distribution of fatalities with respect to temporary support

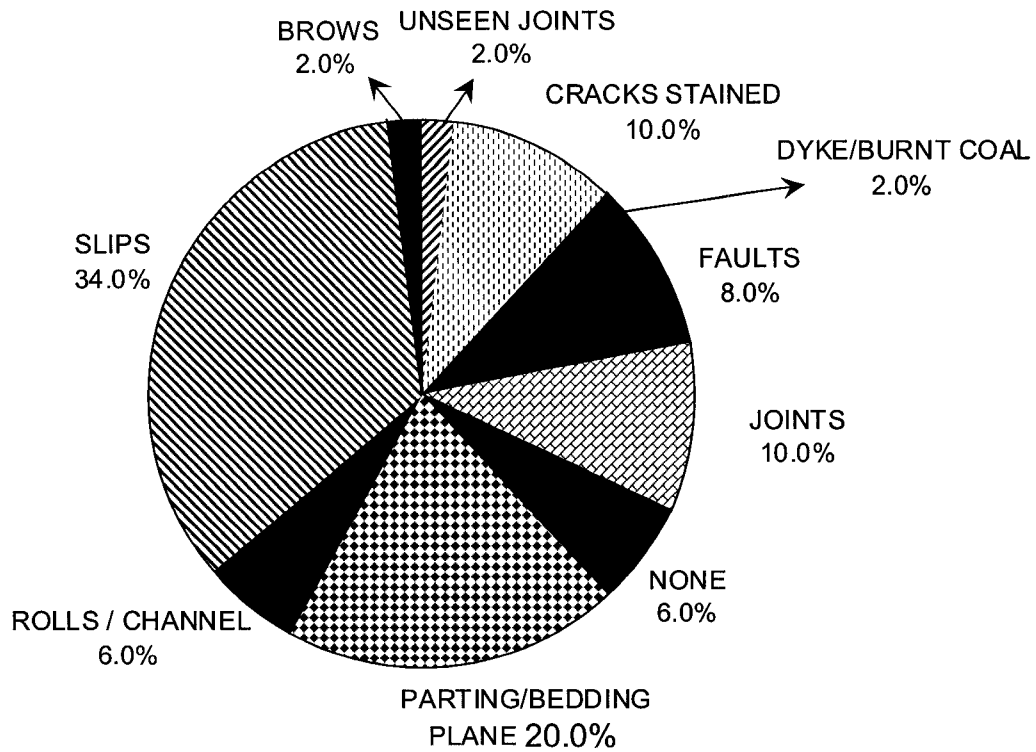

Figure 1.22. Distribution of fatalities with respect to geological discontinuities

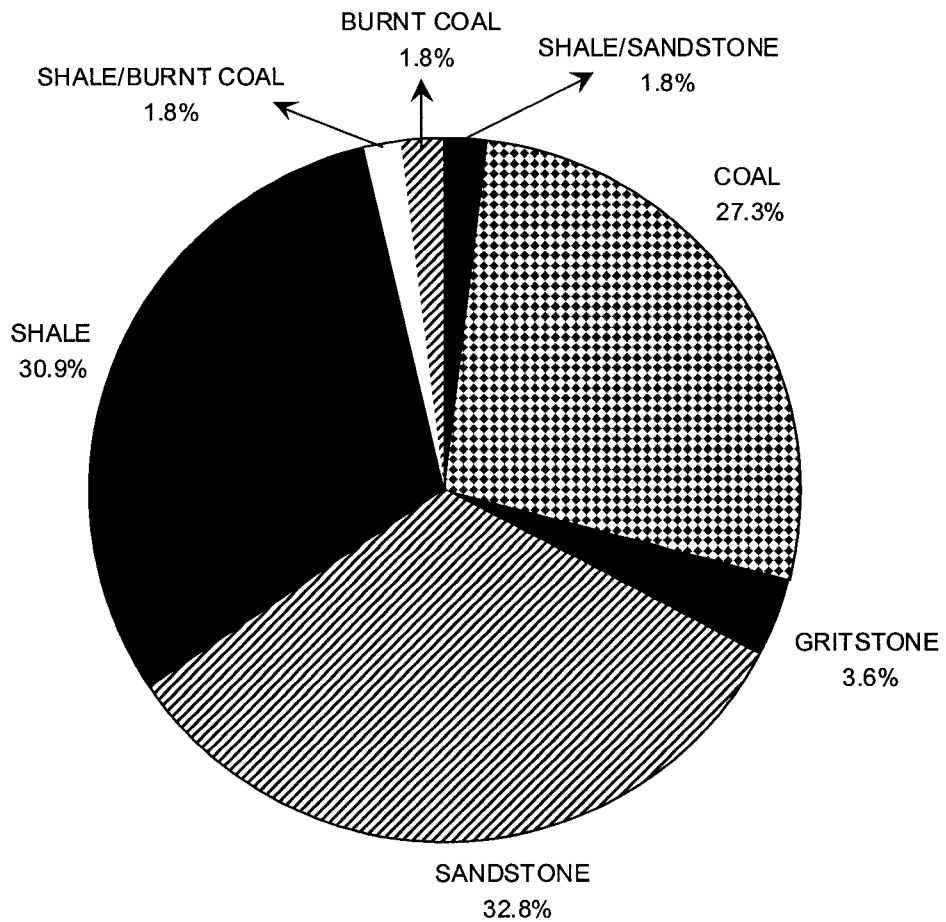

Figure 1.23. Distribution of fatalities with respect to immediate roof

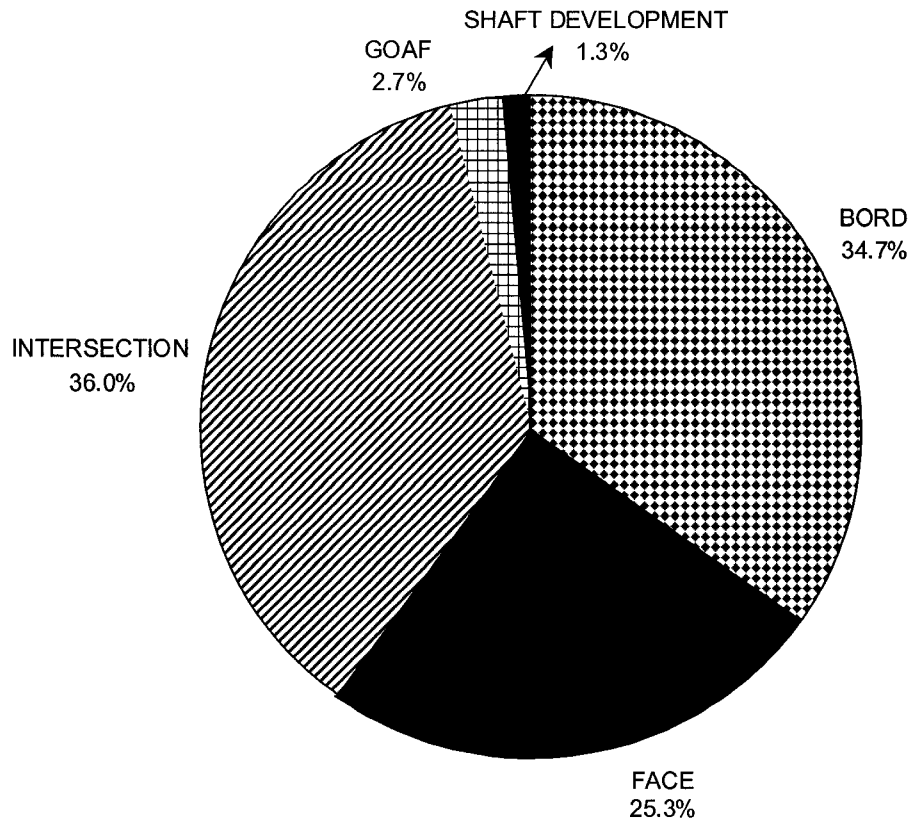

Figure 1.24. Distribution of fatalities with respect to accident location

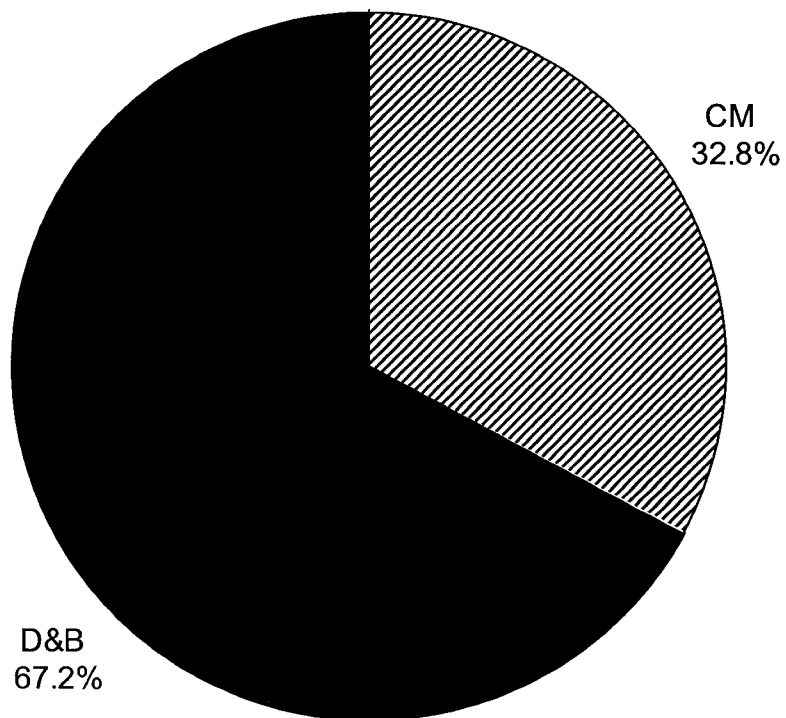

Figure 1.25. Distribution of fatalities with respect to mining method

2 Literature survey of roof support design

2.1 Introduction

Although roofbolting was experimented with in the early part of this century, the main advance in the use of roofbolting occurred after the 1940s, with the early pioneers in the use of roofbolting being from the USA and South Africa. Today roofbolting has become the primary support system in the coal mining industry and most of the underground coal mines (91 per cent) in South Africa are mined under roofbolted roofs. Since the introduction of roofbolts productivity has increased, costs have decreased, and ventilation has improved.

The design of roofbolt patterns in South African collieries has evolved over many years and was based on local experience and judgement by mining personnel.

Significant advances have been made over the last 20 years in the development of chemical anchors, tendon elements and installation hardware. As a result, tendon roof support systems have been progressively applied to more extreme roadway conditions.

During the last 15 years, monitoring of roadway behaviour has been undertaken extensively in overseas underground coal mining operations. Field monitoring, laboratory testing and back analyses using numerical modelling have provided new insight into rock behaviour and the function and performance requirements of rock reinforcement systems.

This section summarizes the most commonly used roofbolting design methods worldwide.

2.2 Roof support in South African collieries

The main objectives of roofbolting are:

- to prevent strata separation and uncontrolled roof falls;
- to maintain and enhance the strength properties of the jointed rock mass through mobilisation of frictional forces.

To achieve these objectives the following basic mechanisms are employed:

- Suspension of a thin roof layer from a massive bed
- Beam building of laminated strata

These two mechanisms are shown in Figure 2.1. Wagner (1985) discussed these mechanisms;

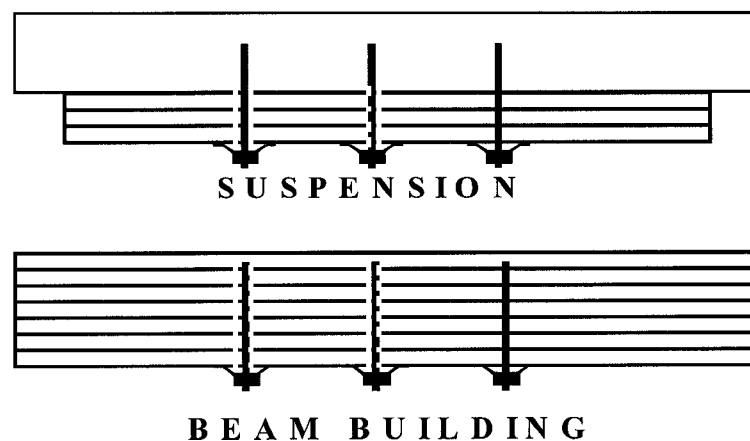

Figure 2.1. Basic roofbolt support mechanisms

Suspension mechanism

The suspension mechanism is the most easily understood and most widely used roofbolting mechanism.

The design of roofbolt systems based on the suspension principle, has to satisfy the following requirements:

- The strength of the roofbolts, SB , has to be greater than the weight, W , of the loose roof layer that has to be carried.

$$\sum_{i=1}^n SB_i > W \quad (2.1)$$

- The anchorage forces, AF , of the roofbolts have to be greater than the weight of the loose roof layer.

$$\sum_{i=1}^n AF_i > W \quad (2.2)$$

- Usually the support design is based on a safety factor, SF .

$$\sum_{i=1}^n SB_i - SF.W \text{ and } \sum_{i=1}^n AF_i - SF.W \quad (2.3)$$

The value of the safety factor depends on the strata conditions, the importance of the roadway and uncertainties with which SB and AF can be determined. A value of $1.5 < SF < 2$ is normally used.

In the case of thin roof beds the spacing between bolts is critical. The general rule is that it should not exceed a value of 10 times the thickness of the layer. Figure 2.2 can be used for roofbolt design purposes. In the case of thicker roof slabs and grouted roofbolts, the length of bolt that is anchored into the competent bed is critical to ensure sufficient anchorage.

In the case of mechanically end-anchored roofbolts, the contact strength of the roof at the position of the end anchor is critical. Contact stresses of 20 to 30 MPa are not uncommon. Such high stresses can only be supported by competent sandstone formations. This aspect has to be taken into account in the design of the support system.

The number, n , of bolts/m² required to support a loose layer or layers of thickness, t , is given by:

$$n = SF \frac{qgt}{P_f} \quad (2.4)$$

where, SF = Safety Factor
 q = density of suspended strata
 g = gravitational acceleration
 P_f = failure load of bolt

The area, A , that may be supported by one bolt is the inverse of n

$$A = \frac{1}{n} \quad (2.5)$$

The required bolt spacing, d , may be determined from:

$$d = \sqrt{A} = \sqrt{\frac{1}{n}} \quad (2.6)$$

The necessary anchor length may be determined by two methods. One is to use destructive pull tests to determine which bond length will allow consistent failure of the tendon prior to anchor

failure. The second method is to determine the mean shear strength, T , by means of short anchor tests. In these tests a short capsule (± 200 mm) is used and the bolt is pulled to failure.

The bond length, L_B , is given by:

$$L_B = \frac{\delta^2 L_c}{D^2 - d^2} \tag{2.7}$$

where, δ = capsule diameter
 D = hole diameter
 d = tendon diameter
 L_c = capsule length

Figure 2.2 given by Wagner shows the relationship between the thickness of loose roof slab, the number of bolts per unit roof area and the roof area that can be supported by one bolt.

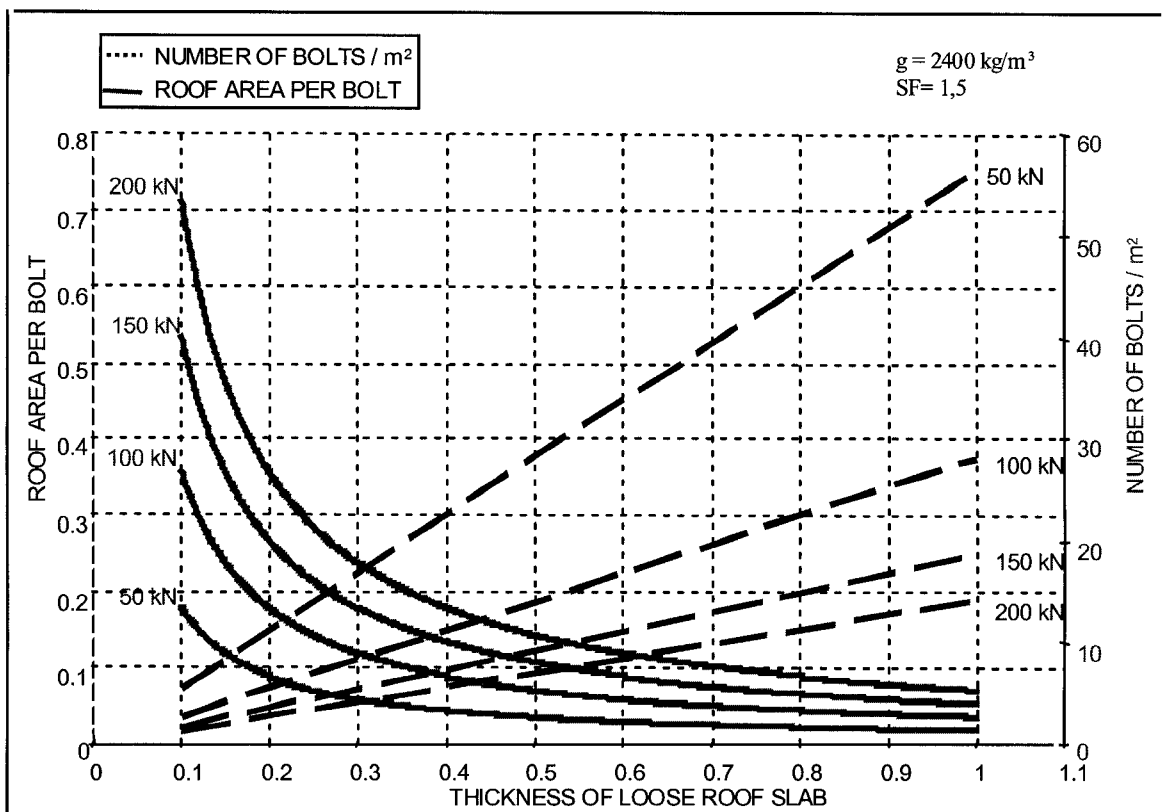

Figure 2.2. Relationship between thickness of loose roof slab and number of bolts per unit area for bolts of 100, 150 and 200 kN failure load (After Wagner, 1985)

Beam Mechanism

In many practical situations, the strata overlying a roadway is thinly laminated. Often there is no competent bed within a distance of a few metres into the roof which could be used to suspend the thin layers on roofbolts. In these cases use has to be made of the beam building mechanism.

The parameters which govern the behaviour of gravity loaded beams with clamped ends are as follows:

$$\text{Maximum bending stress} \quad \sigma_{xy(max)} = \frac{qgL^2}{2t} \quad (\text{MPa}) \quad (2.8)$$

$$\text{Maximum shear stress} \quad \tau_{xy(max)} = \frac{3qgL}{4} \quad (\text{MPa}) \quad (2.9)$$

$$\text{Maximum deflection} \quad S_{max} = \frac{qgL^4}{32Et^2} \quad (\text{mm}) \quad (2.10)$$

where L = roof span (width of roadway)
 t = thickness of roof layer
 q = density of suspended strata
 g = gravitational acceleration

The self-supporting capabilities of horizontal roofbeams was given by Wagner (1985). He found that individual beams with a thickness of less than 0.2 m are not self-supporting even if the strength of the beam material is high.

Figure 2.3 shows the maximum horizontal or bending stress in roof beams of different thickness for bord widths of 5.0 m, 6.0 m and 7.0 m. Also shown is the flexural strength of typical coal measure rocks. According to this diagram relatively thin roof beams can span distances of several metres.

The principle of beam building is to increase the effective thickness, t_{eff} , of the roof beam so that it can be self-supporting.

When a thin roof beam deflects, the upper fibre is shortened and the lower fibre lengthened. As a result, a relative shear displacement will take place between the top layer of the lower roof slab and the bottom layer of the upper roof slab. The objective of roofbolting is to prevent or at least to minimise the relative movement between individual roof layers. This can be achieved by building up frictional forces between layers.

The resistance to sliding between the surfaces depends on three factors. The first is the cohesion (bond) that may exist between the two layers, the second is the friction between the layers, and the third is the normal or clamping force that acts on the layers.

As a rule, full column grouted, tensioned roofbolts under otherwise identical conditions are superior to other types of roofbolts for beam building (Wagner, 1989).

From the shear stress equation, it follows that the shear stress in the roof beam is zero in the middle of the roadway and reaches its maximum value at the roadway abutments.

To resist shearing movement between individual roof layers, bolts have to be concentrated close to the roadway abutments.

In situations where strata separation has already taken place, it is vital that contact between the roof layers is re-established. Often tensioning of bolts is inadequate for this purpose. An excellent means of re-establishing frictional contact between roof layers is to use a hydraulic jack to thrust the roof layers upwards at the time of bolt installation. The use of thrust-bolting is particularly recommended in old roadways which are being re-supported or in situations where it was not possible to install the support close to the heading.

Roofbolts at the side of the roadway should be inclined to penetrate the region of highest shear stresses and to ensure that a portion of the bolt is anchored over the roadway abutments.

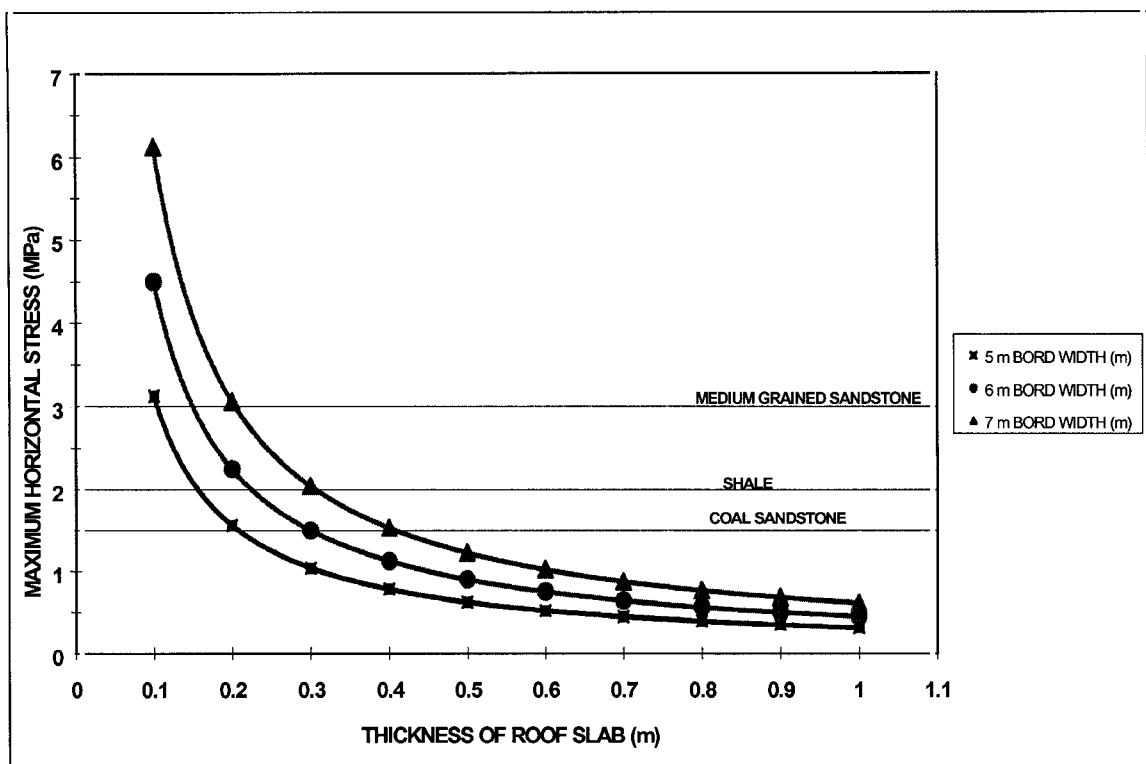

Figure 2.3. Bending stresses in roof slabs of different thickness for roadways of 5, 6 and 7 m width (After Wagner, 1985)

A series of model tests to study beam building concepts verified these general observations, Spann and Napier, 1983. Figures 2.4 and 2.5 summarise the results of the tests. Figure 2.4 shows the different roofbolting patterns which were modelled in the laboratory and Figure 2.5 shows the effectiveness of the various patterns in controlling roof deflection. The effectiveness of roofbolts installed close to the roadway abutments in controlling shear movement, and hence beam deflection, is evident.

Spann and Napier used roof deflection and slip area as criteria to compare rock bolt patterns. They concluded that the most important factor governing beam deflection is the location of the bolts in the beam and the best results are obtained if the bolts are installed close to the clamped end (abutment) of the beam.

The effect of roofbolt density and coefficient of friction between roof layers on the shear resistance is shown on the left hand side of Figure 2.6. The right hand side shows the increase in shear stress. The need for high roofbolt densities close to the roadway abutments is evident and has to be taken into account in the design of roof support patterns.

In investigating the flexural behaviour of the immediate roof, the following assumptions were made:

- i) Each stratum is homogeneous, elastic and isotropic;
- ii) There is no bonding between the strata, i.e. bedding planes have parted and friction and cohesion are zero;
- iii) Each stratum is subjected to uniform loading in both the transverse (due to self weight) and axial (due to horizontal stress) directions simultaneously;

- iv) When the upper stratum loads onto the lower stratum, the deflections of the two strata are equal at each point along the roof span, and
- The upper beam loads the lower beam with a uniform load per unit length of beam,
 - The lower beam supports the upper beam with an equal load per unit length

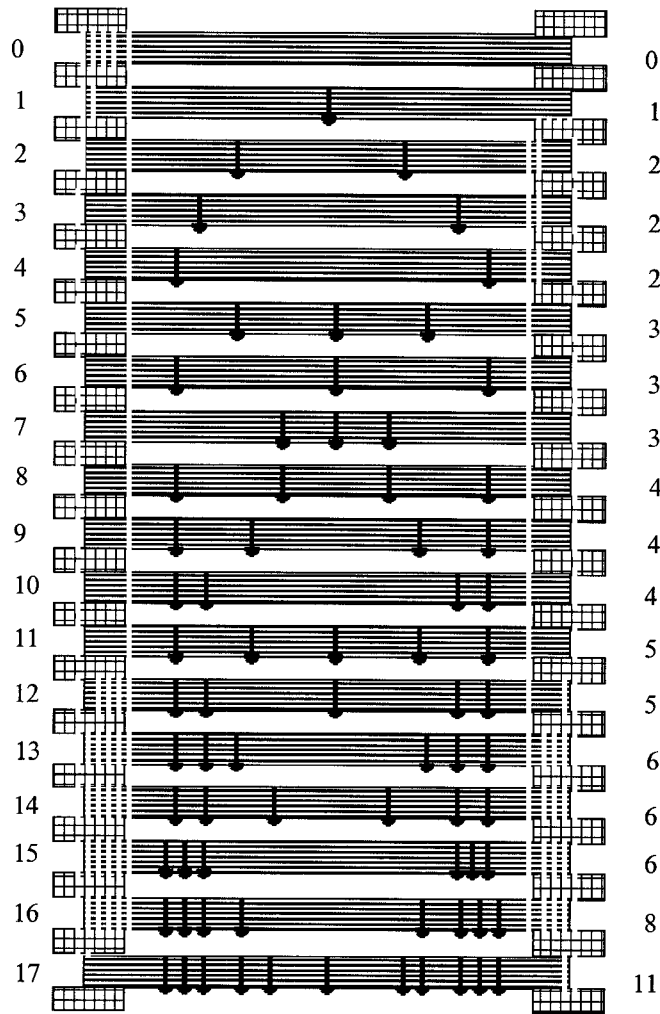

Figure 2.4. Bolt pattern (After Spann and Napier, 1983)

The fundamental principles of roofbolting in South African collieries were discussed by Buddery (1989), where the use of these mechanisms and formulae is explained in detail. The suspension mechanism, due to the simple principles behind it, is very commonly used in South Africa. In the beam mechanism the principle is based on the studies given above. According to analysis by Wagner, for bord widths up to 7 m, roof beams of 0.5 m are self-supporting. Therefore the design intention should be to create a composite beam 0.75 m or 0.9 m thick using full column resin bolts. The number of bolts per row and the spacing between rows are then determined by means of underground trials using a pattern design according to Spann and Napier. This pattern is then monitored for a period of time (two – three months).

Van der Merwe (1989) developed a probabilistic approach to the design of coal mine roof support systems. Van der Merwe highlighted that there is no single solution to a roof support problem underground, for example, a required safety factor can be achieved by varying the tendon length, hole diameter, resin type and roofbolt spacing with an infinite number of systems. However, the cost of those systems is not the same. The only way of establishing the most economical system is to design the roof support by changing the parameters. A procedure, based on failure probability, was described which allows the designer to select the most

effective system for any level of reliability. Also, the choice of a suitable failure probability for roof support is governed by the purpose and expected life of an excavation.

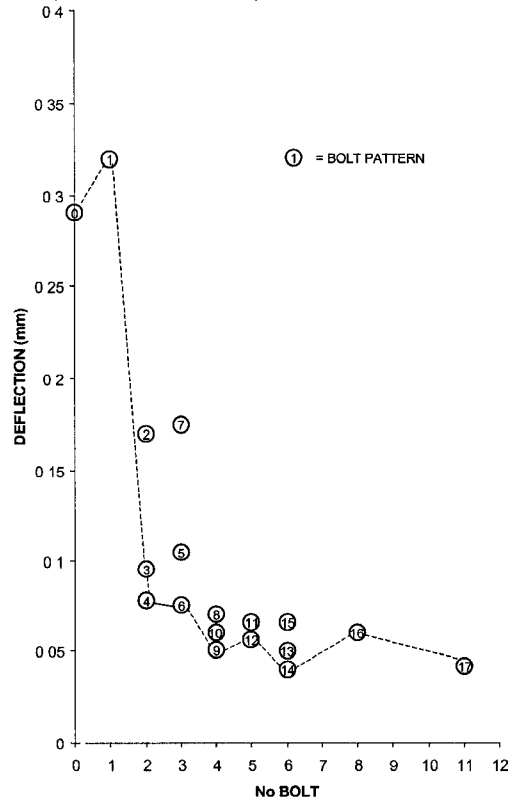

Figure 2.5. Deflection compared to number of bolts (After Spann and Napier, 1983)

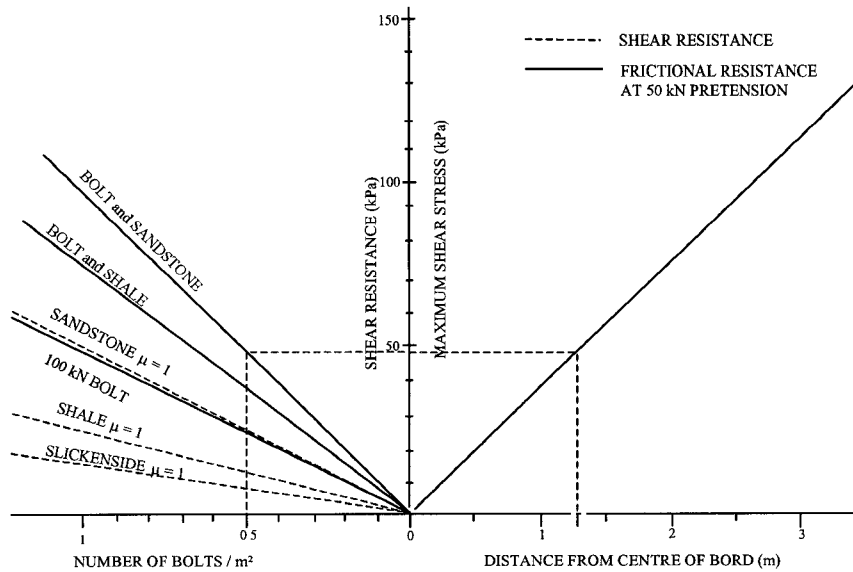

Figure 2.6. Design diagram for roofbolt systems based on control of shear deformations (After Wagner 1985)

Van der Merwe also highlighted the important effect that overdrilling has on support efficiency. The support efficiency was found to be a function of length of hole; for instance, an overdrill of 10 per cent of the anchor length leads to a reduction of 16 per cent in the anchor efficiency.

He concluded that no matter how well a roof support system is designed, it will only perform well if it is applied correctly, therefore, training of personnel and adherence to standards are essential.

Vervoort (1989) investigated roofbolt patterns using the numerical model FLAC to verify the results of Spann and Napier. Three different applications of the friction model were compared:

- i) One weak beam without any support.
- ii) The same beam with one centre full column rock bolt.
- iii) The same beam with two full column rock bolts near to the sides.

Based on the numerical simulations it was concluded that, in the case with no support, there is a deflection of 35 mm, and on 42 per cent of the surface there is an indication of slip. If a centre, full column bolt is inserted into the weak beam, the situation does not improve, as there are four more elements where slip can occur. If two full column rock bolts are installed near to the sides, the roof deflection decreases only slightly, but the slip area decreases significantly. The slip area decreases by 25 per cent compared with the situation where there is no support or where there is a centre bolt. The strength of the weak beam thus increases.

Vervoort (1989) compared the friction and suspension model for one centre roofbolt. The results showed that:

- i) If the support is designed using the friction mechanism a centre bolt has no effect.
- ii) If the suspension mechanism is applied, a centre bolt is effective.
- iii) If a competent strata beam is present in the roof, a support based on suspension is advisable above a support based on friction only.

Vervoort extended his study by carrying out underground investigations to verify the results of the numerical modelling and to gather basic data for research. Two main findings of this investigation were: - without any supplementary support, the total convergence recorded was 40 mm; - with 9 cable bolts the total convergence was less than 20 mm.

Further underground roof monitoring was conducted by Vervoort (1991) using precise levelling. The measurements were conducted both in roadways and intersections. These results were then compared with numerical modelling using the program MINLAY.

Figure 2.7 presents the results both from underground measurements (left) and numerical modelling (right) of a roadway.

For the roadway, the following comments were made by Vervoort:

- Mining steps II, V and VI cause the largest increases in roof deflection, and
- During mining steps III and IV, and after mining step VI, marginal increases in roof deflection are noted.

In nine intersections, monitoring anchors were installed, and the roof was monitored for a period of 50 days. These results again were compared with numerical modelling. The results are presented in Figure 2.8. A close correlation is found between the numerical simulations and the underground measurements:

- For example, at location E, 7.2 mm of roof movement was measured and 7.9 mm was calculated.
- The largest amount of roof movement occurred within the first six days.
- After 17 days, the increase in roof deflection was minimal.

The numerical simulations also showed that, ahead of the face, an elastic roof movement of between 3.0 mm and 4.5 mm occurs.

Vervoort studied the effect of installation time on roof deflection using numerical modelling. The results showed that support has to be installed as close as possible to the face, and if the

support in an intersection is only installed when the whole intersection has been formed, about half of the total elastic roof deflection has already occurred.

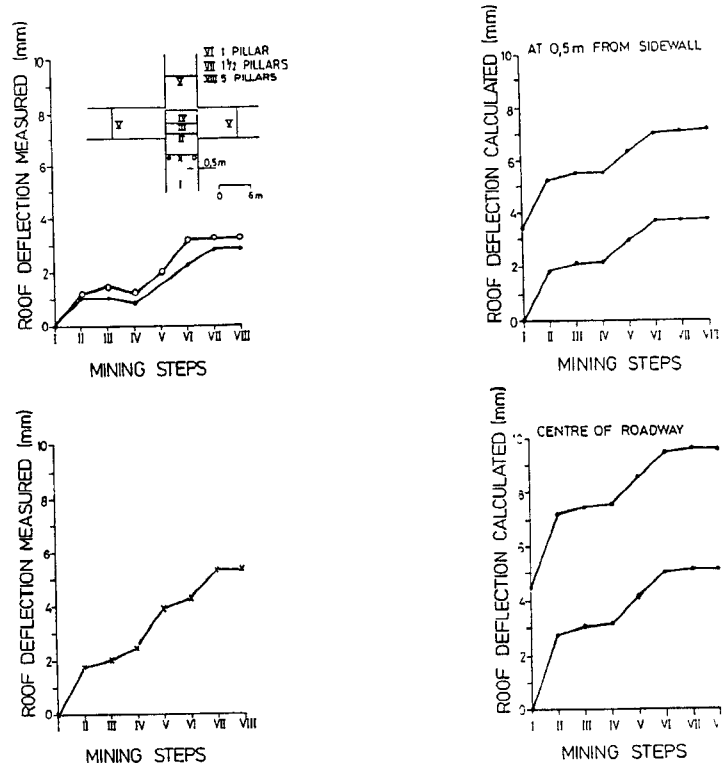

Figure 2.7. Variation of the roof deflection measured (left) and of the elastic roof deflection calculated (right) in a roadway as a function of successive mining steps (After Vervoort, 1991)

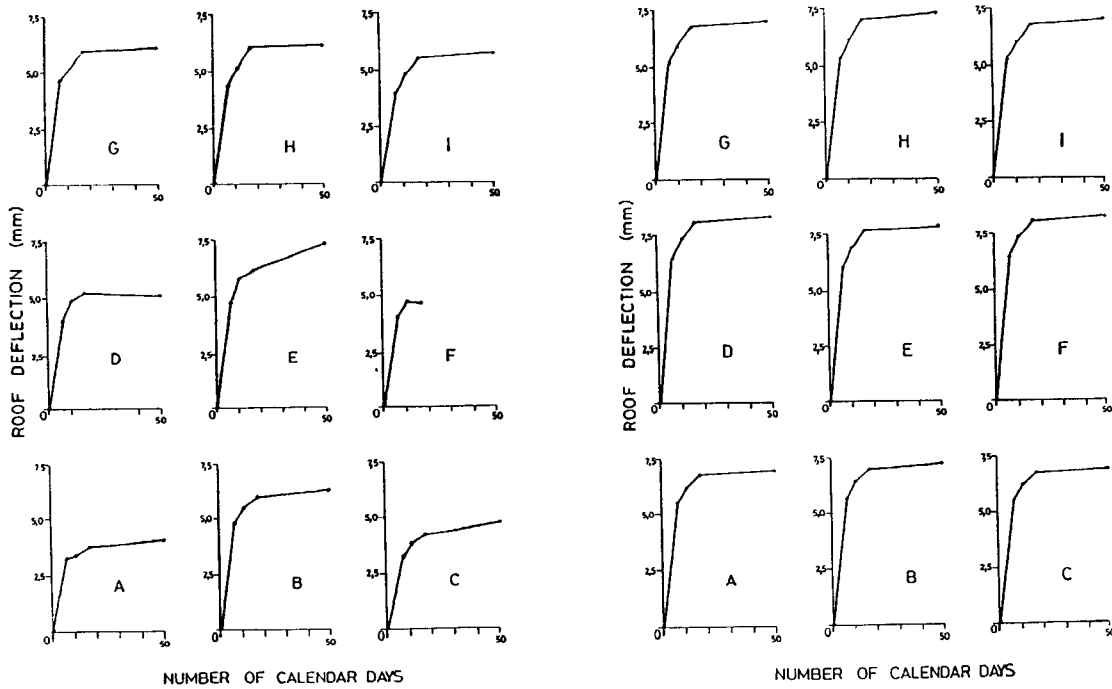

Figure 2.8. Variation of the roof deflection measured (left) and of the elastic roof deflection calculated (right) in an intersection as a function of time (After Vervoort 1991)

In general Vervoort concluded that:

- i) In the middle of a roadway, more roof movement occurs than close to the sides.
- ii) If the coal faces are more than a pillar ahead, the additional increase in roof deflection due to mining is minimal.
- iii) Mining of the three roadways away from an intersection has a significant effect on the increase in roof deflection in the intersection.

In a roadway development, Vervoort and Jack (1991) measured the initial roof deflection around the face to improve the understanding of roof behaviour. Figure 2.9 (left hand side) illustrates the successive mining steps and the location of two measuring points (A and B). The monitoring anchors were installed after step II was mined. Immediately after the installation the initial readings were taken. The increase in roof deflection as a function of time is presented in Figure 2.9 (right hand side).

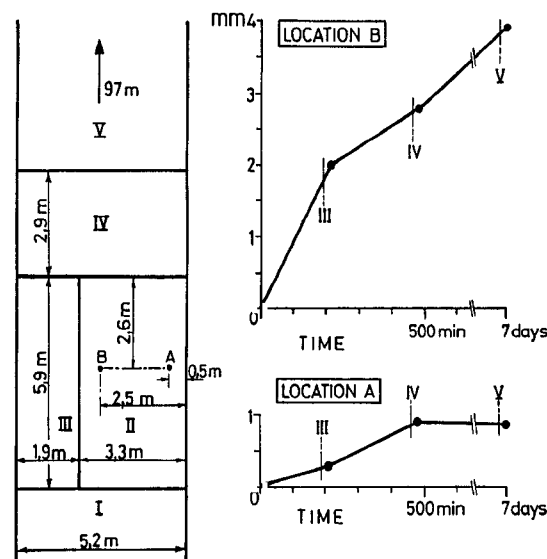

Figure 2.9. Initial roof deflection (in mm) measured around the face during development of a roadway (After Vervoort and Jack, 1991)

From this figure it was concluded that the roof deflection at the two locations was significantly different: the deflection at location B was more than four times the deflection at location A, as expected. Location B was in the centre of the roadway, while location A was closer to the sidewall.

Vervoort and Jack also monitored the roof deflection in an extraction panel. The results of these measurements are given in Figure 2.10, where the increase in roof deflection is presented for three sections in the same panel. The depth of the seam was 180 m and its thickness about 3.0 m. The immediate roof was composed of a layer of laminated carbonaceous shale; above this layer a sandstone beam was present. From Figure 2.10 it was concluded that, for similar geological conditions, different roof behaviour was observed. Apart from the different deflection characteristics, the total roof deflection measured was also significantly different between the three intersections monitored.

These results then were compared with linear elastic models. A linear elastic model with strata with a Young's modulus of 4 GPa gave a good correlation with the in situ measurements (Figure 2.11), however the deflection calculated close to the sidewall was larger than the measured deflection (Figure 2.12). Linear elastic modelling results showed that the effect of a change in the Young's modulus of the strata is much more pronounced for low values of the modulus (e.g. less than 5 GPa) than for large values (e.g. more than 10 GPa).

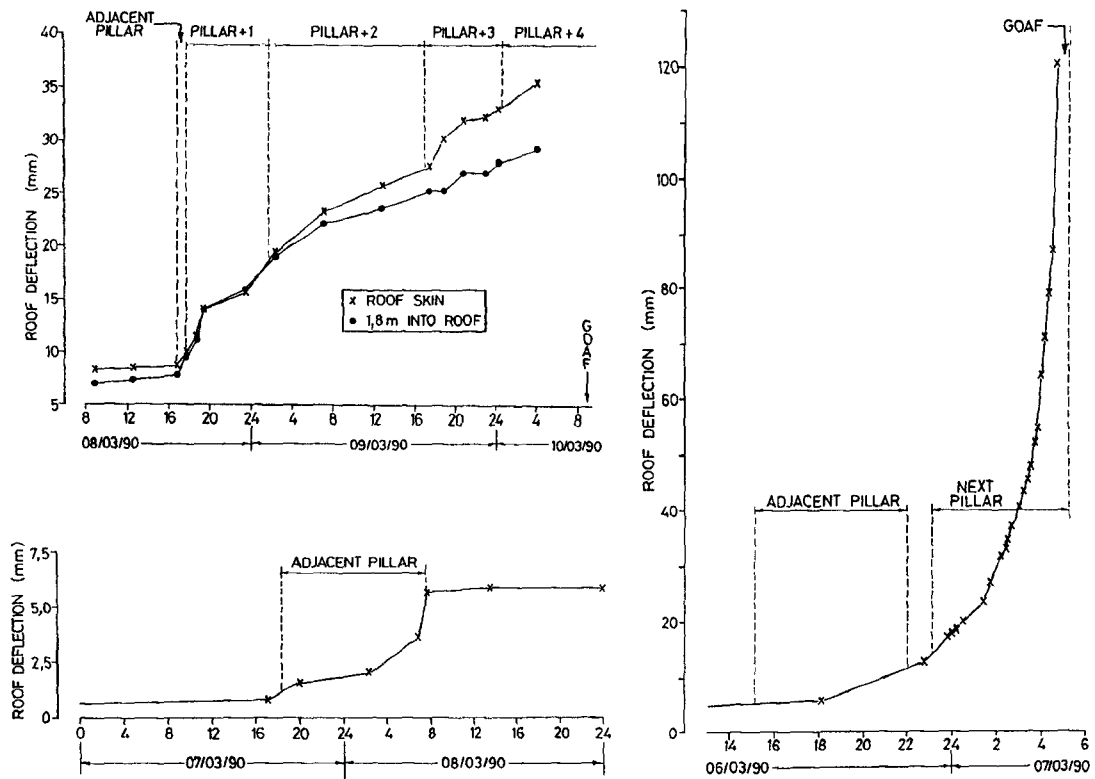

Figure 2.10. Increase in roof deflection in three intersections during pillar extraction

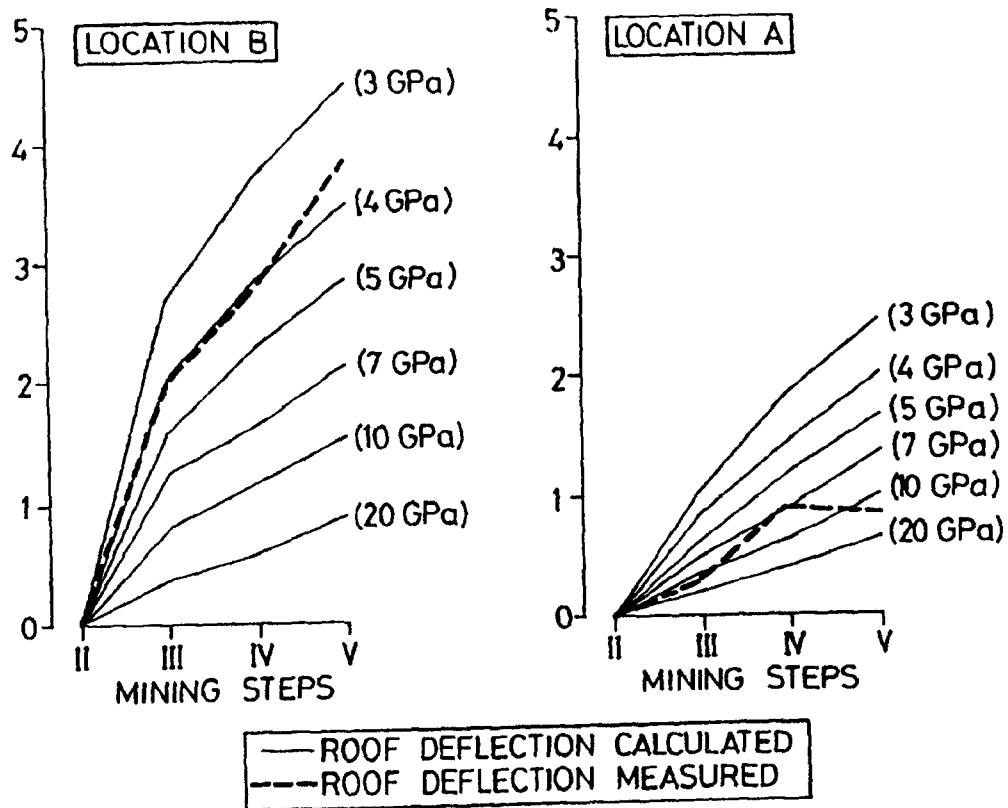

Figure 2.11. Calculated roof deflection (in mm), occurring after mining step II, for various Young's modulus of the strata

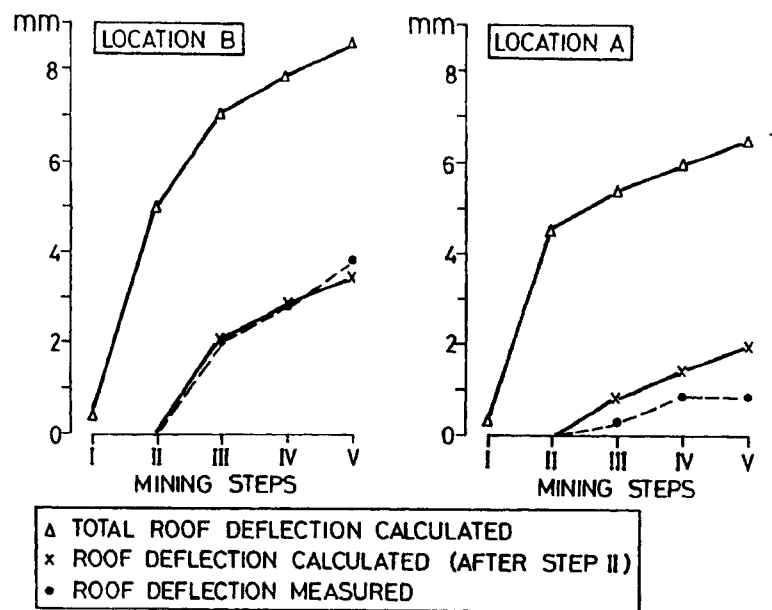

Figure 2.12. Calculated roof deflection around the face during development of a roadway (Young's modulus of strata : 4 GPa)

Vervoort and Jack concluded that, based on the numerical simulation, an indication could be given of the amount of elastic roof deflection which occurred ahead of the face and before the first measurements were taken. Also, using numerical simulations, the underground measurements could be extrapolated within a range of different strata, and, for specific cases, a linear elastic model is an adequate tool. More complex models however add supplementary knowledge and explanations.

In an underground pillar extraction panel, Vervoort and Jack (1991) measured roof deflections in an intersection. Nine 1.8 m long, fully grouted resin bolts were used in this experiment as supplementary support. The experiment took place in two rows of seven intersections across the panel, one row with and one row without supplementary support.

This further study showed that the installation of supplementary support reduced total roof deflection. This effect was most pronounced near to the barrier pillar, where a reduction in roof deflection of 50 to 70 per cent was noted (Figure 2.13), but in the first intersections close to the goaf it was non-existent. Vervoort and Jack also stated that, during pillar extraction, the installation of fully grouted resin bolts can improve roof stability by reducing the roof deflection.

These extensive roof monitoring programmes conducted by Vervoort et. al. for the period 1989 –1992 showed that roof strata vary from panel to panel and even section to section in the same panel. The support used in the mining industry has a significant effect on decreasing roof deflection, thus increasing stability and safety. The installation procedure for support also has a very important role in roof stability and safety, and continuous monitoring of installation is essential to ensure the stability. The time of installation was also found to be an important parameter in stability, as the roofbolts have to be installed as close as possible to the face for maximum benefit and cost effectiveness.

Buddery and Oldroyd (1992) developed a roof and floor classification system for collieries. The following philosophy is applied in devising a suitable classification system:

- i) The rock property tests should be related to the expected mode of failure of the strata.
- ii) The whole spectrum of strata should be tested with particular emphasis being placed on obtaining the properties of the weakest material.

- iii) Large numbers of tests should be able to be conducted simply, quickly, at low cost and in-house.

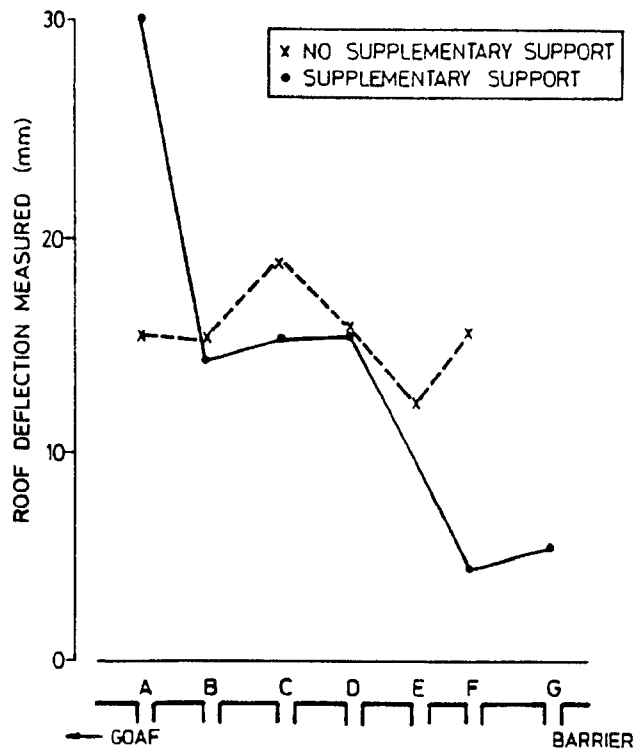

Figure 2.13. Variation of roof deflection measured during pillar extraction across a panel

It was stated that tests designed to indicate the potential for roof failure must represent the frequency of bedding planes and laminations. In roof classification, a Coal Rock Structure Rating (CRSR) system was considered to classify the roof condition. This was initially based on three parameters: RQD, the results of impact splitting tests, and a parameter related to joint condition and groundwater. Due to the impracticality of satisfactorily distinguishing between drilling-induced and natural fractures in the coal measures strata, the RQD parameter was discarded from the system. The third parameter proved to be difficult to determine irrespective of the roof type. It was, therefore, decided to confine the determination of roof ratings to the results of impact splitting tests.

The impact splitting test involves imparting a constant impact to a length of core every 0.02 m. The resulting fracture frequency is then used to determine a roof rating. The instrument consists of an angle iron base which holds the core. Mounted on this is a tube containing a chisel with a mass of 1.5 kg and a blade width of 25 mm. The chisel is dropped onto the core from a constant height according to core size, 100 mm for TNW (60 mm diameter) and 64 mm for NQ (48 mm diameter). The impact splitter caused weak or poorly cemented bedding planes and laminations to open thus giving an indication of the likely in situ behaviour when subjected to bending stresses, and in some instances compounded by blasting.

It is suggested that, when designing coal mine roof support, 2.0 m of strata above the immediate roof should be tested. If the roof horizon is in doubt, then all strata from the lowest likely horizon to 2.0 m above the highest likely horizon are tested so that all the potential horizons may be compared. In this classification system, the strata are divided into geotechnical units. The units are then tested and a mean fracture spacing for each unit is obtained. Using one of the following equations an individual rating for each unit is determined:

$$\text{For } f_s \leq 5 \quad \text{rating} = 4f_s \quad (2.11)$$

$$\text{For } f_s > 5 \quad \text{rating} = 2f_s + 10 \quad (2.12)$$

Where f_s = fracture spacing in cm

This value is then used to classify the individual strata units (Table 2.1) but, for coal mine roofs, the individual ratings are adjusted to obtain a roof rating for the first 2.0 m of roof.

Table 2.1. Unit and coal roof classification system (After Buddery and Oldroyd, 1989)

Unit Rating	Rock Class	Roof Rating
< 10	Very poor	< 39
11 – 17	Poor	40 – 69
18 – 27	Moderate	70 – 99
28 – 32	Good	100 – 129
> 32	Very good	> 130

It was stated that the immediate roof unit will have a much greater influence on the roof and consequently the unit ratings are weighted according to their position in the roof by using the following equation

$$\text{Weighted rating} = \text{rating} \times 2(2-h)t \quad (2.13)$$

Where: h = mean unit height above the roof (m)
 t = thickness of unit (m)

The weighted ratings for all units are then totalled to give a final roof rating. Buddery and Oldroyd (1989) concluded that good agreement between expected and actual roof conditions has been found when using this rating system (Table 2.1).

In 1995 an attempt was made by van der Merwe (1995) to develop a support design for Sasol Collieries. He considered three types of mechanisms, namely sandstone beam failure, beam creation and dead weight in weak roof situations. These mechanisms and the support design are given as follows:

Sandstone beam failure

Three different modes of sandstone beam failure were considered

- a) Flexure under the influence of its own weight, plus the weight of material underneath which is suspended from it by bolting and the weight of softer material overlying it (flexure mode), or
- b) A combination of the above mode and the effect of horizontal stress, or
- c) Pure buckling caused by excessive horizontal stress, as determined with the Euler equation

a) If no joints or cemented joints are present, the failure that will occur by flexure in the intersections is given by:

$$L = 6,389t_s \sqrt{\frac{\sigma_t}{(t_s + t_l + 0.6t_c)F}} \quad (2.14)$$

where: σ_t = maximum tensile stress
 L = length of beam
 t_s = thickness of sandstone beam

- t_l = thickness of the laminated material
 t_c = combined thickness of coal material in the roof
 F = safety factor

b) Equation 2.14 is valid where there is no horizontal stress. If significant horizontal stress is present, the maximum moment is increased thus increasing the bending stress. In this case the maximum permissible span becomes:

$$L = \frac{t_s}{4.2} \sqrt{\frac{3E}{\sigma_H}} \alpha \cos \left[\frac{0.025t_s E}{3\sigma_t \sigma_H / F + 0.025t_s E + 3\sigma_H^2} \right] \quad (2.15)$$

where σ_H is the horizontal stress.

c) Limit stress for pure buckling is given by the Euler equation for intersection where $L_{int} = 1.4L$

$$L = t_s \sqrt{\frac{E\pi^2}{5.88\sigma_H / F}} \quad (2.16)$$

Roadway widths are calculated with Equations 2.14, 2.15 and 2.16. The minimum of these should be regarded as the maximum safe road width.

If slickensided joints are present, then the following equation should be used to calculate the maximum permissible span:

$$L = 2.608t_s \sqrt{\frac{\sigma_t / F}{t_s + t_l + 0.6t_c}} \quad (2.17)$$

Comparison with Equation 2.16 shows that, in the case of slickensided joints, the maximum permissible span is only 0.4 of that of a beam with cemented joints.

Van der Merwe noted that this restriction can be overcome by providing roofbolts through the joint plane. The requirements for this type of bolting were given as follows:

- a) Full column resin grouted bolts must be used,
- b) Bolts must be long enough and inclined such that they penetrate the plane of joint – at least 1.0 m of the bolt must be in solid beyond the joint,
- c) Bolt spacing must not be greater than 1.0 m along the trace of the joint, and
- d) The horizontal distance of the roof between the joint and the bolt must be such that the thickness of the “wedge” at the position where the bolt is installed is at least 0.5 m.

Maximum support spacing to prevent failure of the material underneath a sandstone stratum

If the stability of the sandstone beam is guaranteed, falls of the material underneath it – roof coal and the laminated material – could still occur. The failure of this material can result from either the bolt spacing being wide enough to allow flexural failure between bolts or the anchor resistance being insufficient to successfully suspend the weaker material from the sandstone beam.

The design philosophy chosen in order to ensure that both stability criteria are met is to first determine the maximum spacing between bolts to prevent flexural failure, and then to determine the minimum anchor resistance (the product of anchor length and the anchor’s unit resistance) to prevent suspension failure.

Maximum bolt spacing

For this section, the simplified assumption that the laminae are of equal thickness was made. It was also assumed that the laminations consist of a stiff material such as sandstone and a softer material such as mudstone.

Load is then transferred from the upper soft material to the lower stiffer material. A convenient way of quantifying this effect is to calculate an adapted unit weight of the bottom material, as in the standard composite beam procedure (van der Merwe, 1995). Then, the adapted unit weight, γ_a , is:

$$\gamma_a = \frac{E_l(\gamma_l + \gamma_u)}{E_l + E_u} \quad (2.18)$$

The maximum bolt spacing is then given by the following equation:

$$L_l = \sqrt{\frac{2\sigma_l}{\gamma_a}} \quad (2.19)$$

where L_l is the maximum spacing required to prevent failure of the laminated material.

The next stage is to determine whether or not the roof coal will fail. The composite beam analogy is used. The first step was given to determine whether there is load transfer from the laminated material to the roof coal. This will be the case when

$$\frac{12\gamma_c}{E_c t_c^2} > \frac{12\gamma_a}{E_a t_a^2}$$

where the subscript c refers to coal and a to the combined characteristics of the laminated layer. Due to the assumption that the laminations have equal thickness, E_a is the arithmetic average of the Elasticity moduli of the laminated materials. If load transfer does not occur, Equation 2.22 is used with coal properties to calculate the maximum spacing to prevent roof coal failure.

If load transfer does occur, the adapted unit weight for coal is calculated by:

$$\gamma_a = \frac{E_c t_c^2 (\gamma_c t_c + \gamma_{max} t_{max})}{E_c t_c^3 + E_{lam} t_{lam}^3} \quad (2.20)$$

lam and c represent laminated layer and coal respectively. Equation 2.18 is then used with coal properties and γ_a calculated with Equation 2.19 to calculate the maximum bolt spacing to prevent roof coal failure.

To summarize, the maximum spacing allowed is the following under different conditions:

- 1) If no roof coal is present, the distance is obtained from Equations 2.18 and 2.19.
- 2) If roof coal is present and is not loaded by the laminated layer, the distance is obtained with Equation 2.19 with coal properties.
- 3) If roof coal is present and is loaded by the laminated layer, the distance is obtained with Equations 2.20 and 2.19.

Bolt length and anchor resistance

The final phase of the design procedure is to ensure that the resistance offered by the bolts is sufficient to ensure suspension of the roof coal and laminated layer from the overlying

sandstone. This is done by balancing the weight of the weak material and the resistance offered by the bolts.

$$l_b = \frac{l_{max}^2(25t_l + 15t_c)}{F_b} + t_l + t_c \quad (2.21)$$

- l_{max} = Maximum spacing obtained from previous section
 l_b = length of bolt
 F_b = anchor unit resistance in kN/m.

If both F_b and l_b are fixed

$$L_{max} = \sqrt{\frac{F_b(l_b - t_l - t_c)}{25t_l + 15t_c}} \quad (2.22)$$

If L_{max} determined from Equation 2.22 is less than that obtained from the previous section, it becomes the new maximum spacing which is determined by the bolt characteristics. If the new L_{max} is greater than that obtained from the previous section, the spacing from the previous section is retained.

Beam creation

To create a stable beam, it was stated that the shear strength supplied by the bolts must equal the shear stress generated in the rock (assume the rock to have zero lateral shear strength).

Shear stress is zero in the centre of the beam and increases linearly towards the clamped edges, reaching the maximum value at the edges;

$$\tau = \frac{3\gamma l}{2} \quad (2.23)$$

where:

$$l = \text{distance from centre of roadway.}$$

The shear force supplied per support hole is the shear strength of steel multiplied by the area of the bolt:

$$V = \tau_b A_b \quad (2.24)$$

where:

- V = shear force supplied by bolt
 τ_b = shear strength of bolt
 A_b = cross sectional area of bolt

Then, the number of bolts required per square metre of roof, n , at any position is:

$$n = \frac{\tau}{V} \quad (2.25)$$

$$n = \frac{3\gamma l}{2\tau_b A_b} \quad (2.26)$$

As the τ increases towards the edge of the beam, it follows that the bolt density must also be greater at the edge. Equation 2.26 highlights the following points:

- The annulus between the hole and the bolt should be as small as possible.
- The shear stiffness of the bolt is of prime importance. If it deforms considerably before failure, shear displacement will still occur and the beam will still fail.

- c) Bolt diameter is important - the number of bolts required is inversely proportional to the bolt cross sectional area.
- d) Once more, the narrower the roadway, the less the number of bolts that are required.

If the tensile strength is added to the design, the tensile strength as a force supplied per bolt, F_t is:

$$F_t = \sigma_b A_b \quad (2.27)$$

where: σ_t = tensile strength of bolt
 A_b = area per bolt required

Then, the required number of bolts per metre is:

$$n^1 = \frac{\gamma L^2}{2t \sigma_b A_b} \quad (2.28)$$

In most cases, n^1 from Equation 2.26 will be greater than n obtained from Equation 2.29. In other words, the number of bolts required to supply artificial shear strength will usually be less than the bolts required to supply artificial tensile strength. Van der Merwe stated that if the shear displacement can be prevented the tensile stresses will not develop, therefore making the prevention of shear displacement all the more desirable.

For a first order practical design, the following points were made by van der Merwe (1995).

- a) Calculate bolt density with Equation 2.29, for the worst case, i.e. $l=L/2$.
- b) Incline the outer bolts over the ribside, thereby using the same bolts to also supply at least part of the required tensile strength to supplement the shear strength consideration.
- c) Also install W-straps to increase system stiffness and to improve area cover.
- d) Use the stiffest available steel for the bolts and smallest possible annulus, bearing in mind the requirement for proper resin bonding.
- e) Determine the maximum development distance before bolts are installed by measuring roof displacements with extensometers.
- f) Continually monitor the performance of the system and adapt as required.

Support design for dead weight in weak roof situations

An alternative to creating a beam, which will be stable, is to accept that it will fail and to design a support system which is capable of suspending the failed roof material. This is in essence a simple exercise, based on balancing the weight of the broken material with the support capacity.

The weight of broken material is obtained by observation of roof falls underground, the usual shape being the one shown in Figure 2.14.

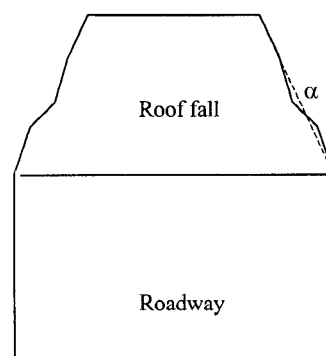

Figure 2.14. Cross section view of typical roof collapse in weak rock

The number of bolts, n , is given as;

$$n = \frac{4\gamma[Bh - h^2 \cot \alpha]}{\sigma_s \pi d_s^2 F} \quad (2.29)$$

where: F = safety factor,
 h = height of roof fall
 d_s = steel diameter
 B = bord width
 γ = unit weight of roof material

The total anchor area which is required, A_a is:

$$A_a = \frac{w}{\tau_r} \quad (2.30)$$

where τ_r = shear resistance of the resin rock contact plane.

The total anchor length is then:

$$l_A = \frac{A_a}{\pi d} \quad (2.31)$$

or

$$l_A = \frac{\gamma(Bh - h^2 \cot \alpha)}{\pi \tau_r d_h} \quad (2.32)$$

The anchor length per bolt is then:

$$l_a = \frac{l_A}{n} \quad (2.33)$$

If vertical anchors are used, the bolts must be long enough to penetrate beyond the material to be suspended by at least the anchor length (van der Merwe, 1995). Thus,

$$l_b = h + l_a \quad (2.34)$$

where: l_b = bolt length

Van der Merwe stated that savings can be achieved by installing inclined anchors. In this case:

$$l_b = \frac{s}{\cos \beta} + l_a \quad (2.35)$$

where: s = distance roofbolt is installed from ribside
 β = inclination of bolt, measured from the horizontal

The limitation of these design equations is that they may only be applicable to conditions similar to those at the Sasol mines, where the scheme was developed and they need to be verified for other conditions.

2.3 Roof support design in the U.S.A.

Panek (1956 (a, b, c), 1957, 1962 (a, b), 1964) investigated roofbolt design and mechanisms in the U.S.A. for a period of eight years. This study was summarized by Obert and Duvall in 1967. Obert and Duvall stated the advantages of roofbolting as follows;

1. The cost of roofbolts is comparable with the cost of timber supports. However, rock bolting is more permanent, hence maintenance costs are reduced.
2. Because roofbolts are subjected to less damage from blasting or other mining operations than metal or timber props, bolting can be installed close to the working face. Whereas timber support usually interferes with underground haulage and the movement of machinery, roofbolts do not.

3. In larger openings or in industrial installations, timber support is usually impractical and the cost of linings or steel sets or arches can become prohibitively costly. In this type of opening roofbolts may provide an effective means of reinforcing the surface rock in both laminated and jointed, or fractured formations. The fact that the roofbolting is relatively permanent and requires a minimum of maintenance makes this procedure especially suitable for all installations designed for a long lifetime.

Obert and Duvall considered four types of reinforcement; suspension, friction effect, combined friction and suspension, and dead weight loading.

Considering the suspension mechanism five different modes are considered, Figure 2.15: unsupported (free end) lamina underlying a very thick body of rock; same lamina held at its edges; two-member roof model, where the order of the beams is such that the ratio of the load per unit length to the flexural rigidity of the lower member is greater than that for the upper member; same model with reverse ratio; and number of beams of different thickness.

If the lamina is completely suspended by the bolts, Figure 2.15 (a), the load per bolt W_b is given by:

$$W_b = \frac{\gamma BL}{(n_1 + 1)(n_2 + 1)} \quad (2.36)$$

where:

- γ = unit weight of lamina
- t = thickness of lamina
- B = width of lamina
- L = length of lamina
- n_1 = number of rows of bolts
- n_2 = number of bolts per row

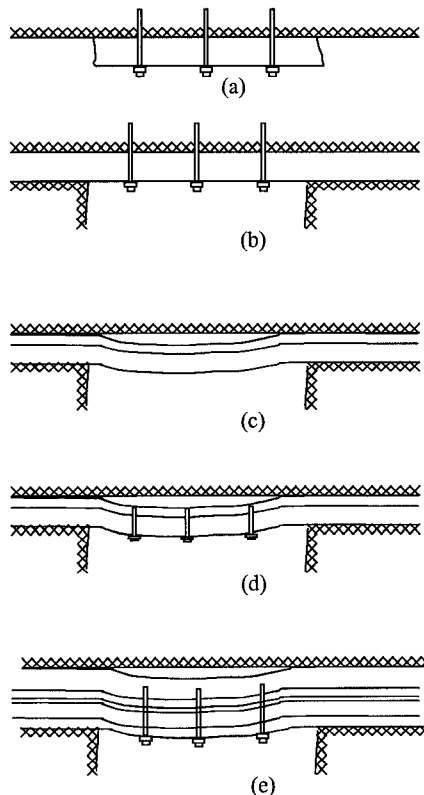

Figure 2.15. Roof supported by bolting. (a) Supported. (b) Supported with fixed ends. (c) Supported from thick lamina. (d) Supported including thick lamina. (After Obert and Duvall, 1967)

If the same lamina is held at its edges, Figure 2.15 (b), and a sufficient number of bolts are installed and tightened so that over its entire surface the lamina is just brought in contact with the overlying body of rock, the load per bolt W_b is given by;

$$W_b = \frac{\gamma_2 t_2 BL}{(n_1 + 1)(n_2 + 1)} \quad (2.37)$$

This is the same as for the case when the ends of the beam were unsupported.

If the laminae act as clamped beams, and the contact between them is frictionless, and if the order of the beams is such that the ratio of the load per unit length to the flexural rigidity of the lower member is greater than that for the upper member (Figure 2.15 (c)), the latter will rest on and be partially suspended by the lower member; in this case the maximum deflection and maximum stress in the two-member unit can be determined by;

$$W_b = \frac{L^4 (\gamma_1 t_1 + \gamma_2 t_2)}{32(E_1 t_1^3 + E_2 t_2^3)} \quad (2.38)$$

$$\sigma_{\max(1 \text{ or } 2)} = \frac{L^2}{t_{(1 \text{ or } 2)}} \left(\frac{\gamma_1 t_1 + \gamma_2 t_2}{t_1 + t_2} \right) \quad (2.39)$$

where the subscripts 1 and 2 apply to the thicker and thinner laminae respectively, and where $\sigma_{\max(1)}$ is the maximum stress in the lamina whose thickness is t_1 , etc. For this mode, the load transfer is given by;

$$\Delta q = \frac{q_2 E_1 I_1 - q_1 E_2 I_2}{E_1 I_1 + E_2 I_2} \quad (2.40)$$

If both the unit weight and modulus of elasticity of the laminae are approximately equal, as is often the case in successive laminae, the load transfer is from the thinner to thicker member and, correspondingly, the strain (and stress) will be decreased in the thinner member and increased in the thicker member. Obviously, for this case rock bolting cannot affect the load transfer; hence the suspension effect due to bolting is zero.

If the order of the two-members roof is reversed so that the ratio of the load per unit length to the flexural rigidity is greater for the upper member (Figure 2.15 (d)), without rock bolting the two members will flex independently and a separation between them will result. However, if rock bolts are installed and tightened so that the lower member and upper members just touch (in frictionless contact) and the bolt spacing is close enough together so that the distribution load is uniformly transferred along both the length and width of the beam, this case is identical to the two-member case given above, except that the load transfer is made through the bolts. Thus the suspension effect is given by Equation 2.40 and the load per bolt (n bolts per row) is

$$W_b = \frac{\Delta q L}{n} \quad (2.41)$$

This example can be generalised for k beams for which

$$\frac{q_1}{E_1 I_1} > \frac{q_2}{E_2 I_2} > \dots \dots \frac{q_k}{E_k I_k} \quad (2.42)$$

by substituting

$$\overline{Et}_2 = \frac{\left(\sum_i^k E_i t_i^3 \right)}{\sum_i^k t_i} \quad (2.43)$$

and

$$\overline{\gamma} = \frac{\left(\sum_i^k \gamma_i t_i \right)}{\sum_i^k t_i} \quad (2.44)$$

for Et^2 and γ in the following equations to derive the maximum deflection of the bolted assembly and the maximum stress in each member.

$$\eta_{max} = \frac{\gamma L^4}{32Et} \quad (2.45)$$

$$\tau_{(xz)max} = \frac{3\gamma L}{4} \quad (2.46)$$

$$\sigma_{(x)max} = \frac{\gamma L^2}{2t} \quad (2.47)$$

Generally a laminated roof is made up of a number of beams of different thicknesses that may occur in any possible arrangement, as illustrated in Figure 2.15 (e), Obert and Duvall (1967). In this case without bolting some beams or combinations of beams may rest on other beams or combinations of beams, and between other beams or combinations of beams separations may occur. A general treatment of the suspension effect for this problem was not given by Obert and Duvall. However, by considering the ratios of the load per unit length to the flexural rigidity of individual members and subgroups to determine which will load (rest on) other members or groups and which will separate, the problem can be analysed by the procedure given above.

The reinforcement of a laminated horizontal roof by the friction effect results from the clamping action of tensioned rock bolts, which creates a frictional resistance to slip on the interface between laminae, thereby reducing the flexure and, correspondingly, the stress and strain in the laminae.

Obert and Duvall summarized the various factors that affect the strain in a centrifugally loaded model. These factors are: K , the centrifugal loading factor; γ , unit weight of the model material; L , the span; t , the lamina thickness; b , spacing between rows of bolts; N , the number of bolts per row; F_b , the bolt tension; h , the bolt length; and E , the modulus of elasticity of the model material. The model strain ε_x was expressed as a function of dimensionless products of these variables, that is,

$$\varepsilon_x = f_1 \left(\frac{K\gamma L}{E}, \frac{L}{t}, \frac{L}{b}, N, \frac{F_b}{EL^2}, \frac{h}{t} \right) \quad (2.48)$$

The maximum bending strain in a clamped beam occurs at the clamped ends and is given by;

$$\varepsilon_{max} = \frac{\gamma L^2}{2Et} \quad (2.49)$$

where:

γ	=	unit weight of material
L	=	span
E	=	modulus of elasticity
t	=	thickness of laminae

Obert and Duvall considered two clamped beams of the same material, the first composed of a single member of thickness t and the second composed of four laminae of thickness $t/4$ (Figure 2.16). Also assumed is that there is no frictional resistance to slip on the interface between laminae.

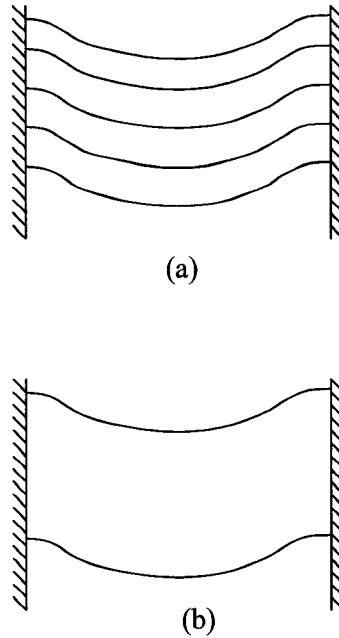

Figure 2.16. Multiple (a), and single (b) lamina roof

The maximum bending strain in the unbolted model specified above is also given by Equation 2.49, but it is designated by ϵ_{nfs} (where the subscript nfs designates no friction or suspension). If ϵ_f is the maximum strain in the bolted model, then the decrease in strain due to bolting $\Delta\epsilon_f$ is

$$\Delta\epsilon_f = \epsilon_f - \epsilon_{nfs} \quad (2.50)$$

where the subscript f indicates with friction

From a regression analysis of the data from model tests (after Panek), ϵ_{nfs} and ϵ_f as a function of the dimensionless products in Equation 2.51 were determined. This relationship, expressed as the ratio of $\Delta\epsilon_f/\epsilon_{nfs}$, is

$$\frac{\Delta\epsilon_f}{\epsilon_{nfs}} = -0.265\mu(bL)^{-1/2} \left[NF_b \frac{\left(\frac{h}{t} - 1\right)}{\gamma} \right]^{1/3} \quad (2.51)$$

where μ is the coefficient of friction between the bending planes. The reinforcement factor RF due to the frictional effect is defined as

$$RF_t = \frac{1}{1 + \left(\frac{\Delta\epsilon}{\epsilon_{nfs}}\right)} \quad (2.52)$$

Equations 2.50 and 2.51 serve as design equations for determining the degree of reinforcement produced by tension bolting equal-thickness laminae in either a model or the prototype structure. Because these equations do not contain any quantity related to the strength of the laminae material, they cannot be used as such to determine the strength of either a model or prototype roof. If $\Delta\varepsilon_t/\varepsilon_{nfs}$ in Equation 2.51 is substituted in Equation 2.52, the reinforcement factor can be expressed in terms of the parameters of the model or prototype. This expression is presented graphically in Figure 2.17 in which it is assumed that all laminae have the same unit weight, thus, if

Lamina thickness	$t = 3$ in (76.2 mm)
Bolt length	$h = 4$ ft (1219.2 mm)
Bolt tension	$F_b = 10000$ psi (703 kg/cm ²)
Number of bolts per row	$N = 3$
Spacing of rows	$b = 4$ ft (1219.2 mm)
Roof span	$L = 16$ ft (4878 mm)

the reinforcement factor RF is 1.9 as indicated by following the chart along the path *abcdefg*.

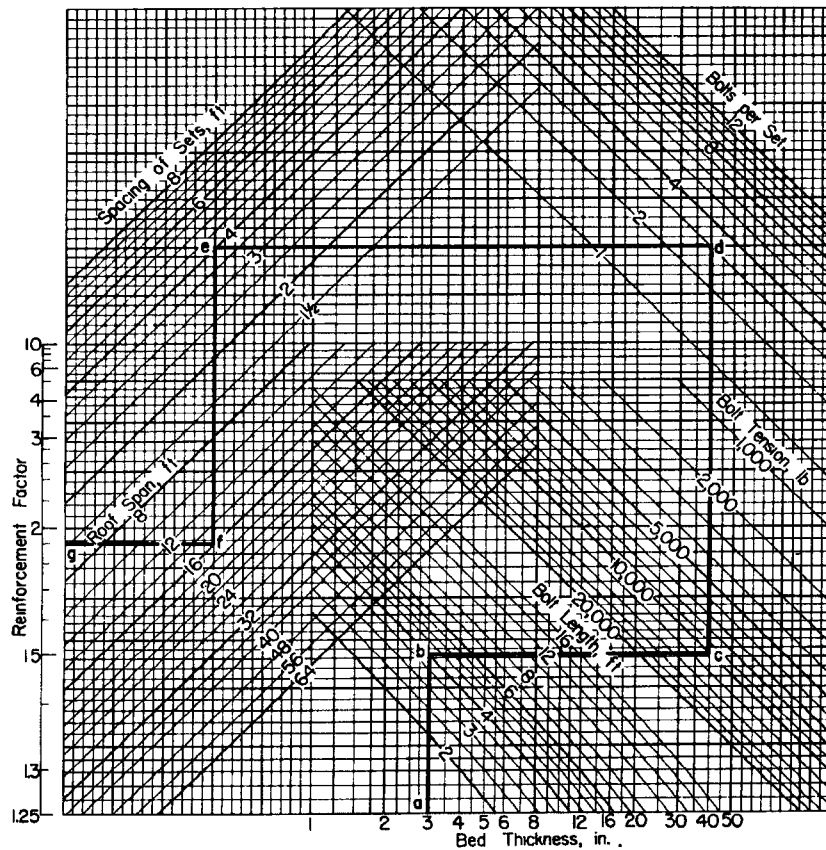

Figure 2.17. Roofbolting design chart for friction effect (After Obert and Duvall, 1967)

Reinforcement of laminated roof by combined friction and suspension: Obert and Duvall (1967) stated that using one design equation that can treat this general case would be difficult and not too practical because of the problems involved in determining the exact parameters of the prototype. However, by making several simplifying assumptions that were found to have only a negligible effect, a modified method was developed.

Considering the friction effect first, a regressional analysis of the data from centrifugal tests on models made with laminae of different thickness and unit weight showed that the average thickness t_{av} and the average unit weight γ_{av} can replace t and γ in Equation 2.51 without serious

error. Since $\Delta\varepsilon_f/\varepsilon_{nfs}=\Delta\sigma_f/\sigma_{nfs}$ (because the laminae are assumed to be perfectly elastic), Equation 2.51 can be written

$$\frac{\Delta\sigma_f}{\sigma_{nfs}} = -0.265(bL)^{-1/2} \left[NF_b \frac{\left(\frac{h}{t_{av}} - 1 \right)}{\gamma_{av}} \right]^{1/3} \quad (2.53)$$

where $\Delta\sigma_f = \sigma_f - \sigma_{nfs}$

The model tests also disclosed that the combined effects of friction and suspension are multiplicative, and was expressed in the form

$$\sigma_{fs} = \sigma_{nfs} \left(1 + \frac{\Delta\sigma_f}{\sigma_{nfs}} \right) \left(1 + \frac{\Delta\sigma_s}{\sigma_{nfs}} \right) \quad (2.54)$$

where $\Delta\sigma_f = \sigma_f - \sigma_{nfs}$, and the subscripts s, fs, f, nfs denote the effects due to suspension, friction and suspension, friction and no friction or suspension, respectively. Also it is determined that

$$\frac{\Delta\sigma_s}{\sigma_{nfs}} = \alpha C u_i \quad (2.55)$$

where α is a constant depending on the bolt spacing, that is, the number of bolts per row N , and C is a constant, depending on the number of laminae in a bolted unit. The value of α and C are given in Tables 2.2 and 2.3.

Table 2.2. Values of α for various N

Bolts per Set, N	3	4	5	6	8	10	12
α	0.750	0.889	0.938	0.960	0.972	0.980	0.984

Table 2.3. Values of C for various number of strata

Number of strata	3	4	5	6	8	10	12
C	0.953	0.900	0.865	0.838	0.800	0.772	0.751

The quantity $1+u_i$ is the ratio of the flexural rigidity of the i th lamina to the average flexural rigidity of all laminae, that is, for a bolted unit of i laminae

$$1 + u_i = \frac{(\gamma_1 t_1 / \gamma_i t_i) + (\gamma_2 t_2 / \gamma_i t_i) + \dots + (\gamma_i t_i / \gamma_i t_i)}{(E_1 t_1^3 / E_i t_i) + (E_2 t_2^3 / E_i t_i) + \dots + (E_i t_i^3 / E_i t_i)} \quad (2.56)$$

If all laminae have equal E and γ (which is a reasonable approximation for bedded sedimentary rocks such as those commonly found over coal deposits), the above equation goes to

$$1 + u_i = t_i^2 \frac{\sum t_i}{\sum t_i^3} \quad (2.57)$$

Thus, if Equations 2.53, 2.55 and 2.56 or 2.57 are evaluated in terms of parameters of a prototype roof, the reinforcement can then be determined from Equation 2.57.

It was stated that the treatment of flat-laminated roof was considered on the basis of beam theory. In this treatment it was assumed that the roof laminae were not intersected by joints, fractures, or other planes of weakness. If this type of roof is intersected by occasional joints running parallel to the span, beam theory is still valid; but if the planes of weakness run perpendicular to the span, the bending moments of the roof laminae will be strongly affected and beam theory is not applicable, although the latter type of roof can be stabilised by suspension, provided that the rock bolts can be anchored in a thick competent laminae. For this case the bolting design should be based on dead weight loading.

Also, igneous and many metamorphic rocks are not laminated but generally contain one or more sets of joints, which may be completely bonded, partially bonded, or completely unbonded. The spacing and spatial orientation of these sets of joints will vary from point-to-point. These rocks may also contain other planes of weakness such as shear zones and faults. When an underground excavation is created by conventional means, that is drilling and blasting, the joints and faults in the proximity of the excavation are loosened by blasting vibration and, in addition, randomly oriented fractures are created. Obert and Duvall stated that these fractures and loosened joints occur to a depth ranging from 3 to 6 ft (0.9 to 1.8 m) or more from the opening surface, thus creating a zone of relatively incompetent or "loose" rock surrounding the openings as illustrated in Figure 2.18.

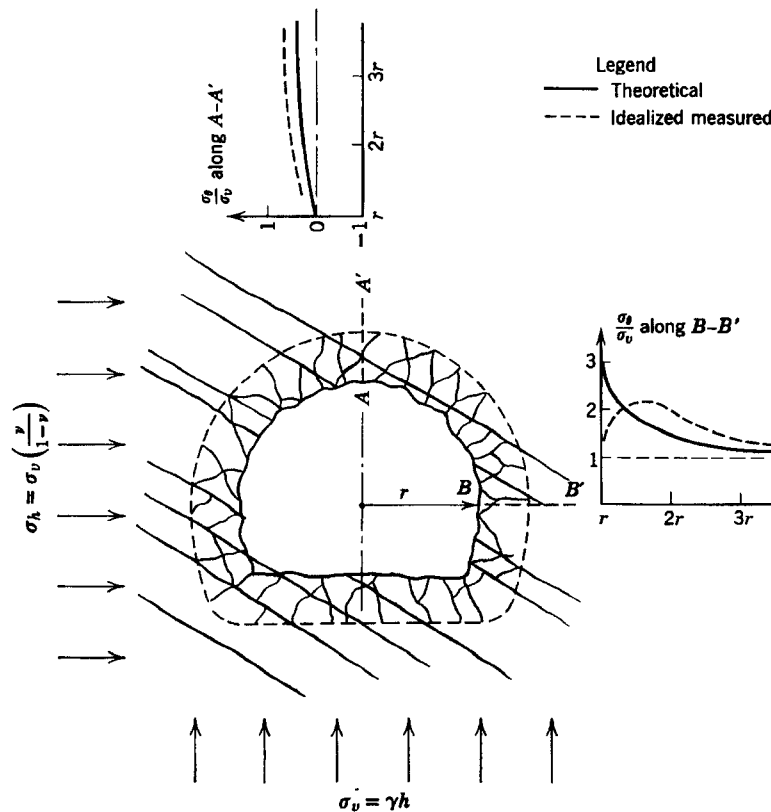

Figure 2.18. Theoretical and idealized measured stress distribution around opening in gravity stress field ($\nu=0.25$) (After Obert and Duvall, 1967)

One conclusion from this analysis was that the complex state of stress and the lack of homogeneity in fractured and jointed rock are such that an analytic treatment of the reinforcement furnished by rock bolting is not feasible. However, Obert and Duvall (1967) gave some insight into the manner in which this reinforcement is achieved by considering the forces acting across joint planes. In Figure 2.19 (a), if F_b is the bolt load normal to a unit area of the fracture plane, F_p is the force parallel to the surface acting on the same unit area, $\tan \phi$ is the coefficient of friction of the joint plane, and α is the angle the normal to the joint plane makes

with the surface, then the force acting parallel and normal to the joint plane is $F_p \sin \alpha$ and $F_b + F_p \cos \alpha$. The condition necessary for stability is

$$\frac{F_p \sin \alpha}{F_b + F_p \cos \alpha} < \tan \phi \quad (2.58)$$

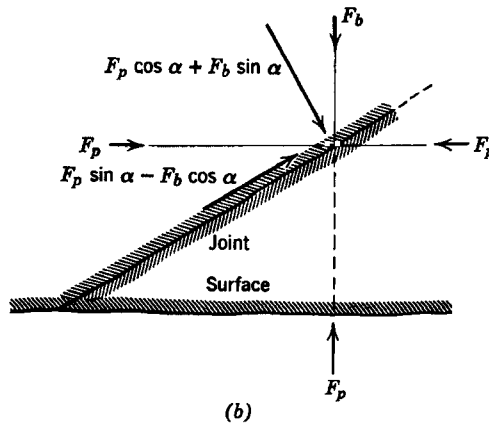
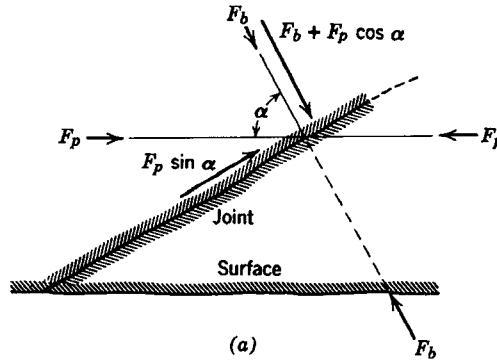

Figure 2.19. (a) Bolt normal to joint. (b) Bolt normal to surface (After Obert and Duvall, 1967)

which can be written as

$$\frac{F_b}{F_p} > \sin \alpha (\cot \phi - \cot \alpha) \quad (2.59)$$

If $\alpha < \phi$ no bolt is necessary, as shown by letting $F_b = 0$ in Equation 2.58. On the other hand, F_p must be very small if bolting is to be effective in stabilising the joint.

If the bolt is installed perpendicular to the surface (Figure 2.19 b), the condition necessary for stability is

$$\frac{F_p \sin \alpha - F_b \cos \alpha}{F_p \cos \alpha + F_b \sin \alpha} < \tan \phi \quad (2.60)$$

Obert and Duvall illustrated some of these principles with examples which can be found in his referred publication. Although this work contributed greatly to the analysis of roofbolting reinforcement, several important factors were not taken into consideration in his studies, including the analysis of the flexural behaviour of a generalized immediate roof and the effect of axial loading due to high horizontal stress. Moreover, the maximum bending stress instead of

the total stress was used in his proposed design of a roofbolting system; such an approach is valid only when the horizontal stress is non-existent or very small (Peng, 1986).

2.4 Roof support design in Australia and UK

Australian roof support design was discussed by Gale et. al. The design of the reinforcement systems required to stabilise mine roadways was developed through the application of field measurement techniques. These techniques allow the level of security of a given opening to be determined from an assessment of the loading within the reinforcement, the extent of roof deformation and experience.

The measurement methodology is summarized in Figure 2.20 which illustrates the following aspects of the technique:

- i) Definition of the lithology of the roof strata and variation in its physical properties.
- ii) Quantification of the effect of confinement, such as that which is provided by reinforcement, on modifying the strength properties of the rock.
- iii) Definition of the position, magnitude and timing of failure within the roof strata.
- iv) Quantification of the load generation within the reinforcement members.

Gale et. al. stated that, for a given roof lithology, the behaviour and stability about an excavation will be controlled by the magnitude of the stress acting relative to the strength of the strata about the excavation. The design of the reinforcement systems to maintain roadway stability must therefore be related to the deformation mechanisms occurring within the strata at the various stress levels. The stress levels were divided categories: low stress environments, moderate stress environments, high stress environments and very high stress environments.

Low stress environments: Where the stress acting in the roof strata is not sufficiently high to cause fracture or failure of discrete units of the rock to occur, the forces generated in the reinforcement restrict delamination of the bedded strata and enhance its spanning characteristics.

A relative low density of reinforcement is required in this environment with typical even spacing of bolts.

This style of behaviour is usually limited to low horizontal stress environments such as areas of shallow cover and moderately good quality rock.

Moderate stress environments: Under moderate stress conditions, it is more probable that fracturing of stiffer bands within the roof strata will occur. Under these conditions, the reinforcement is designed so as to maintain the structural integrity of the roof by controlling the dilation of the fractured layers and maintaining their residual strength. With an adequate design, the roof deformation can be maintained at low levels and a high level of stability maintained.

Bolting patterns within this environment are typically related to driveage direction. Specific patterns of bolts are used in roadways driven at different angles to the principal horizontal stress. The reinforcement distribution reflects the level and distribution of rock deformation.

High stress environments: As the relative stress level is elevated, the level of rock failure and the depth into the roof that rock failure occurs increase. The primary role of the reinforcement is to maintain sufficient strength within the fractured ground so that it can act as a self supporting structure. The reinforced failed rock can then provide resistance against roadway distortion.

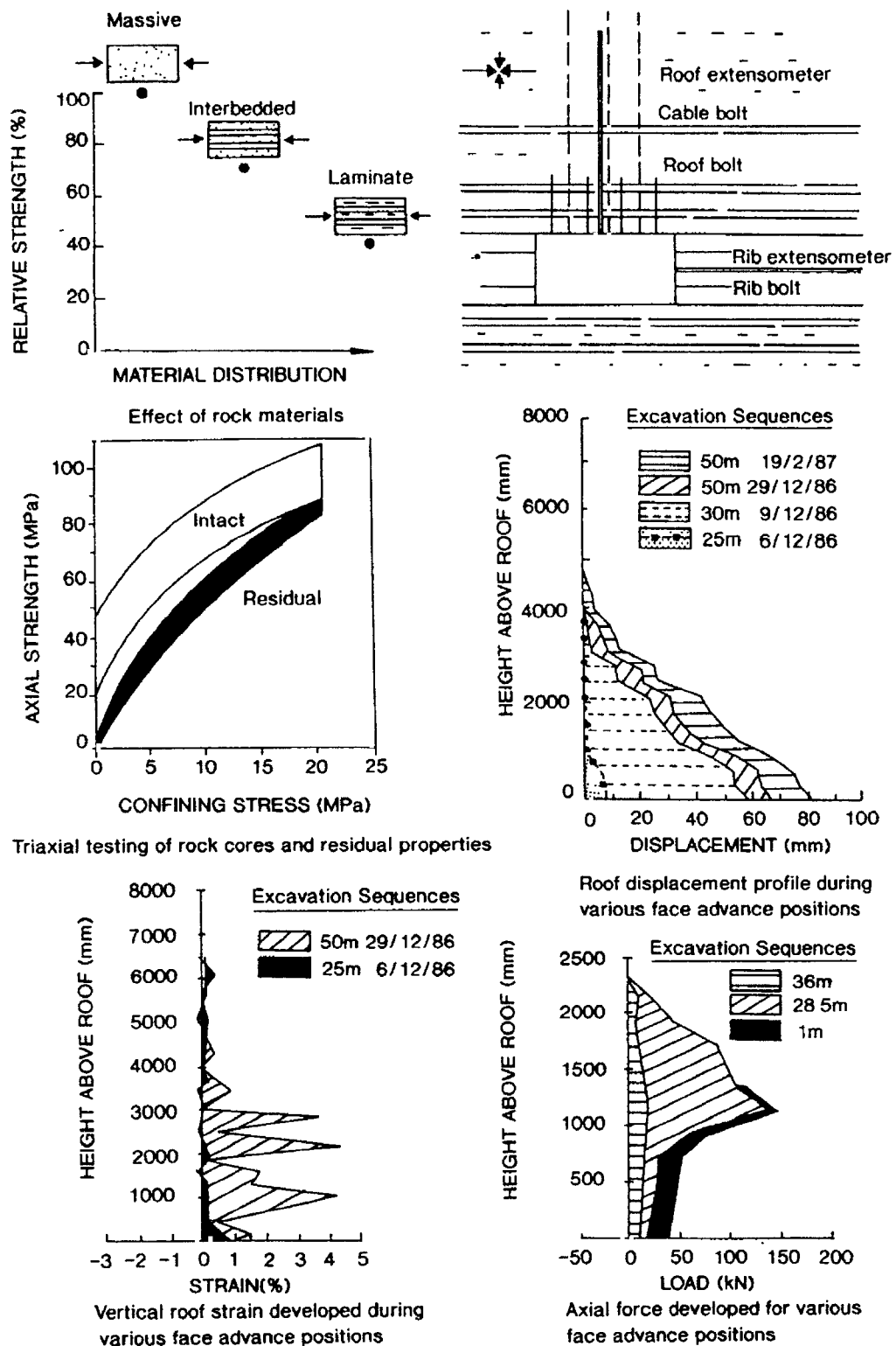

Figure 2.20. Comparison of roof behaviour and stress distribution with different reinforcement practice (After Gale et al.)

By maintaining the load bearing capacity and integrity of the bolted section of the roof strata, the reinforced rock will minimise further stress redistribution around the opening leading to a higher level of stability being maintained. This is achieved through minimising the height to which failure occurs within the roof strata.

Typically, a high density of high capacity reinforcement is required to maintain a stable roadway under these conditions. With an optimised design it is not unusual for a large percentage of the

bolts to exceed their yield capacity. This is a function of the efficiency of the reinforcement in generating load in response to the deformation occurring and is required to provide the confining forces which are maintaining stability.

Very high stress environments: Where the stresses significantly exceed the strength of the rock mass, for some distance into the roof, floor and ribs about the roadway, conventional reinforcement practice may not be sufficient to maintain the integrity of the immediate strata. In these conditions there is a possibility that the load bearing capacity of the immediate roof cannot be maintained leading to further stress redistribution and failure higher into the roof strata. Under these conditions the use of secondary high capacity reinforcement systems such as cable bolts provide a method to stabilise the opening by providing confinement to the rock well above the bolted horizon.

Gale et. al. stated that, within a single area of a colliery it is possible that the strata behaviour can change, as the acting stresses change, due to geological or mining induced factors. These factors are given as: i) depth - the magnitude of the stress acting on the roadway in general will increase with the depth of mining; ii) direction of driveage - depending on the ratio of the minor and major horizontal stress, the effective stress acting across the opening can vary with the direction of driveage; iii) mining induced stress concentration -during the extraction of the coal seam using either pillar recovery or longwall methods, stress concentration will occur around the extraction area.

Gale et. al. found that, with the possibility of the stress levels varying over the extent of the colliery and during the extraction cycle of the seam, it is critical to define the response of the roadway to the differing magnitudes of the stressfield. Since the development of techniques for rock and reinforcement monitoring, the aim is to define the range of the anticipated behaviour using field mapping techniques and measure the actual performance under these conditions.

Extensive monitoring over a wide range of conditions showed that, for a certain lithology in a given roadway width and vertical stress regime, a relationship exists between the magnitude of roof deformation and the height to which significant failure into the roof is generated (height of softening).

Figure 2.21 illustrates this relationship for a range of Australian collieries (Gale et. al.).

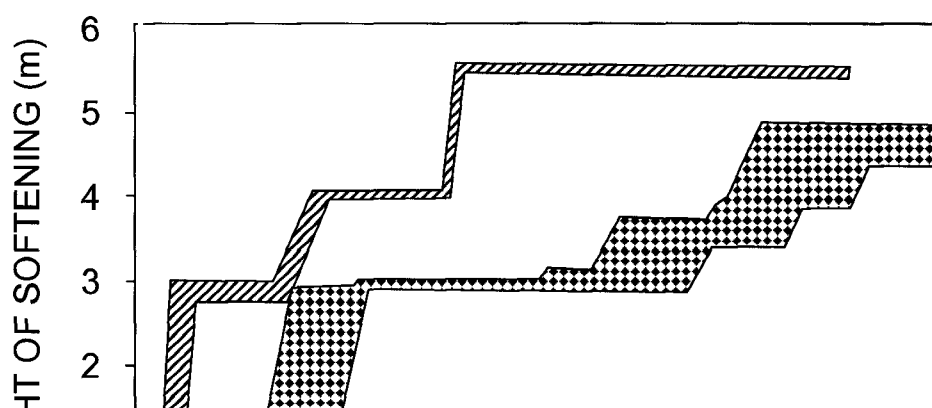

The results of the field based investigations coupled with

- i) extensive measurement of the stress changes occurring around the extraction areas,
- ii) measurement of the actual stress distribution within the roof strata under different reinforcement strategies,

enabled a high level of understanding of the behaviour of rock and reinforcement under known conditions.

With this understanding of the mechanics of the behaviour, computational methods are utilised to assess rock and reinforcement performance. These models are used for realistic modelling of the rock and its associated reinforcement behaviour. For use in the design of both mine layout and reinforcement, the modelling enables a relationship between deformational criteria (total displacement and height of softening) and level of stress to be determined.

Gale et. al. gave one of the typical relationships established by the modelling for a given mine in Figure 2.22. It was noted that, under low stress levels, the deformation occurring is low and greater flexibility can exist in the level of reinforcement and, more specifically, timing of reinforcement placement (Zone 1). Under these conditions, significant opportunity exists to optimise the reinforcement placement through the control of cut out distance and potential sequencing of support placement. At a given level of stress (onset of failure within roof), the level of deformation increases more rapidly (Zone 2). In this environment, the optimisation of the reinforcement placed can increase the stress levels tolerated before significant displacement levels occurs. Under very high stress levels, high deformation occurs even where high reinforcement densities are used (Zone 3). In this environment, options such as alteration of layout and stress relief options can be considered as an alternative to the use of secondary reinforcement methods.

Gale et. al. stated that the results showed that the magnitude of stress increase required to move from Zone 1 to Zone 3 can vary significantly; under certain lithological conditions the stress magnitude required may be as low as 5 MPa.

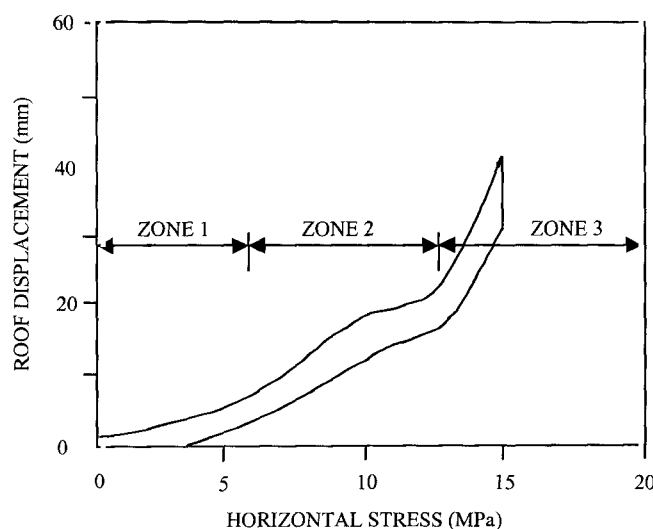

Figure 2.22. Relationship between total roof displacement and stress magnitude at a given colliery (After Gale et. al.).

Facing bad ground conditions, which include present single-entry longwall operations, the Angus Place Colliery near Lithgow in New South Wales has become a leader in innovative ground control in Australia (Syddell, 1998). Due to the poor ground conditions, the mine has implemented a roof monitoring system based on tell-tales and extensometers.

Butcher presented a case study of Angus Place Colliery and its development of a roof control management strategy for controlling highly stressed, highly structured and relatively weak ground. A continuous roof convergence monitoring system (RoofTalk) was developed providing instantaneous data to face personnel indicating the relative stability of roof and ribs.

The majority of roof and rib support systems currently in use in Australian mines are used at Angus Place.

Roadway development encountered severe geologically disturbed zones. These zones were found to contain a high frequency of gouged, strike slip faults which were stress active, with principal horizontal stress magnitudes of 30 – 40 MPa.

Data collected from instrumentation, mapping, testing and experience established several areas of need:

- Percentage strain plots from sonic probe extensometer revealed roof expansion zones at 2.4 (top of the bolted horizon), 3.1 (coal-stone interface), 4.5 and 5.0 m. Thus most expansion was occurring rapidly above the bolted zone.
- Results from standard 300 mm embedment pull tests indicated superior bolt anchorage occurred in claystones above the thick coal.
- There was a need for cable support to be applied at the working face and to be capable of providing instantaneous high capacity support.
- Variations occurred throughout the mine in roof lithology, geological structure, in situ stress and roof strength. There was a need to predict, identify and rank these variations into categories.
- Roadway width was identified as a critical stability criterion. The mechanism of failure involved rib drag out at 100 to 150 mm convergence. This increased the roadway width by 1500 to 2000 mm. A need existed to provide a reaction to rib displacement by an improved rib support strategy. A high level of confinement was required at the rib roof interface where gutter and roof shear were propagated. Generally, roadway widths would have to be reduced.
- Any roof support strategy would have to be well designed, managed and monitored to enable practical application.

Analysis of the needs led to the development of a roof control management strategy for Angus Place Colliery.

The roof was divided into four categories, Table 2.4, and sub categories. Each category describes a type of roof that can be stabilised by a particular support type. The sub categories define the placement, density, length and timing of support. The sub categories are given in Appendix 1.

Table 2.4 Different roof categories for Angus Place Colliery (After Butcher)

CATEGORY	SUPPORT TYPE
A	Roofbolting
B	Flexi bolting
C	Cable bolting
D	Polyurethane, strata replacement cribs, bags, etc

Routine monitoring was established in all new drivages. The frequency of monitoring was developed according to the overall stability of the ground.

A response system was developed to determine who is responsible for what and when different roof support strategies should be applied or discontinued. Thus the roof management strategy was divided into three sub systems:

- Roof support systems
- Roof control response system
- Roof stability monitoring

The interaction of these three systems provided the correct roof support for the roof conditions in a timely manner for Angus Place Colliery.

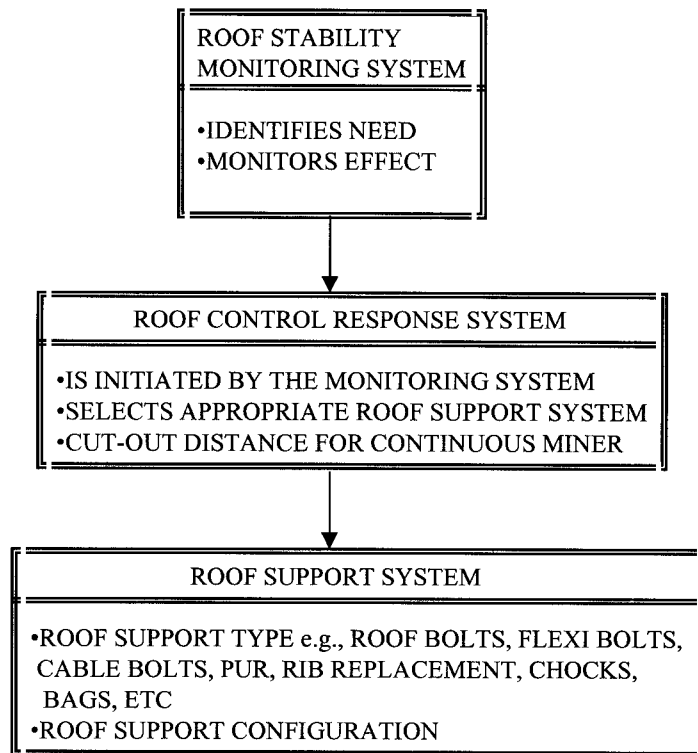

Roof stability monitoring system: Data from routine roof monitoring is used to trigger various roof reinforcement strategies and monitor the effect after installation. The frequency of roof monitoring depends on the ground classification:

- Type A : Every 50 m
- Type B : Every 30 m
- Type C : Every 20 m

Three types of roof convergence monitoring are used:

- Sonic probe extensometer – used to determine roof failure behaviour
- Two point tell tales – used where one or two data points are required to initiate a roof support response
- “Roof talk” continuous monitoring system. This system was developed to provide continuous on line data from a roof convergence instrument.

Roof control response system: This system selects the support type for different levels of reinforcement. It also determines who should add support, and who has the authority to reduce support.

Support selection is triggered by:

- Roof convergence monitoring
- Predicted roof behaviour (e.g. stress notching)

- Observed physical signs (e.g. presence of geological structure)

Support reduction occurs when convergence stabilises after a set time exposure. It can only be initiated by senior management personnel.

Response trigger points are validated by

- Measured performance of support systems
- Computational modelling.

Computational modelling is used to predict roof behaviour when similar roof support systems are placed in varied geological and geotechnical environments, or alternate roof support systems are placed in similar environments.

The impact of horizontal stress is best dealt with in Australia by choosing the right gate road and longwall retreat direction. In some circumstances the effect of high horizontal stress cannot be reduced. In these circumstances three main methods are used;

1. Stress relief by roadway softening or caving
2. Stripping or systematic widening of the entire face
3. Stripping or partial widening of the face

One important finding of this study obtained from sonic probe extensometers was that while the roof failure occurs at a total displacement value of approximately 250 mm, the point of critical escalation of roof failure was approximately 150 mm.

Unfortunately Gale's work is not explained in detail, but these two Australian roof support design methods showed that the roof support design in Australia is based on extensive monitoring to identify the different geotechnical areas. This data is then used to identify the most appropriate roof support pattern. Numerical modelling is also used to verify the design. The validity of this design method has been proved in many cases and is applied to United Kingdom (UK) mines as well. Until the 1970s, roofbolting played no major part in the UK coal mining. Through the 1970s roofbolting was used more in UK mines as support. An investigation on USA and Australia mines was conducted and in general terms it was stated that USA strata conditions were better on average than Australian conditions which, on average, were better than UK conditions. In the UK it became recognised that Australian conditions were closer to UK conditions than those generally seen in the USA. Early in 1987 a visit was made to Australia by senior British Coal Corporation officials to study the application of Australian Technology to rock behaviour and to rock bolting applied to in-seam roadways. This system was introduced into the UK and a standard form of exemption was in place by early 1986, with the BCC (Code of Practice – roofbolting on face), agreed by the MI (Mines Inspectorate) as a safe system of work, being issued in 1987. In 1985/6 some 1.7 per cent of face salvage used rock bolting. This figure approached 50 per cent by 1988/89 and the technique is now recognised as standard practice, freely allowed under exemption, provided the Code is adopted (Williams, 1994). By mid-1990 a Code of Practice for Rock Bolting in Roadways, with detailed technical notes of guidance, was issued.

Siddall and Gale (1992) discussed the roof support design in the UK. The science of strata control was considered as the application of scientific principles to certain goals; these principles are:

- i) understanding the behaviour of rock or strata under known conditions;
- ii) determining methods to control the strata under known conditions;
- iii) determining methods to predict the response of strata under conditions other than those for which current experience allows assessment
- iv) determining methods of controlling the strata within the limits dictated by mining operational viability in the conditions predicted outside those for which current experience allows assessment.

Siddall and Gale (1992) considered two main concepts of how to approach rock stabilisation in underground coal mines. These are roadway support and roadway reinforcement.

Roadway support techniques can act in a number of modes and they are typically targeted at addressing the conditions which prevail in the final state of the deformation pathway.

Roadway reinforcement techniques are typically targeted to provide stabilisation capability during the early stages of the roadway deformation pathway either to reduce the severity of later deformation stages or to eliminate deformation altogether (Siddall and Gale, 1992).

Roadway reinforcement utilises rockbolts or other reinforcing units to develop forces within the rock to create a self supporting rock structure which stabilises the ground about the roadway, without the requirement of additional standing support.

Roadway reinforcement systems use rockbolts in an active manner to develop forces necessary to create strength in the broken rock to maintain stability and to provide resistance against strata movement under high stress conditions.

Siddall and Gale (1992) stated that reinforcement methods behave in two main modes, beam building and rock strengthening.

Beam building utilises the forces developed to restrict delamination of bedded strata and enhance its spanning characteristics. The system is designed to enhance the strength of bedding planes in the rock which may otherwise allow the rock mass to break up.

This conceptual approach is considered to be most applicable where the rock mass has remained mainly intact under relatively low horizontal stress conditions such as shallow, low deformation environments where only limited reinforcement is required to maintain roof integrity. Beam building has been found to be inappropriate under high stress and high deformation conditions as the rock mass is no longer intact and other factors have a greater influence than bedding plane stability.

Rock strengthening utilises the forces developed in rockbolts and cablebolts to maximise the strength of fractured and failed rock around the roadway. The system is designed to maintain sufficient strength within the failed (fractured) ground to act as a self-supporting structure which can provide resistance against roadway distortion. Rock strengthening has been found to be most applicable under conditions of high horizontal stress and deformation conditions where the overstressed rock mass is fractured, such as routine stabilisation of roadway drive within the moderate to high stress environment. In situations of very high stress or anticipated high deformation, secondary reinforcement in the form of 8.0 to 10 m cablebolts is recommended.

Siddall and Gale (1992) stated that because Australian and British strata conditions are similar and the fact that the Australian routinely supported difficult drivages solely on bolts, a technology transfer agreement was concluded in 1987. The code of practice for the "support of Mine Roadways by rockbolts" came into effect and is based on a proven approach which was developed by British Coal to ensure the safe introduction of roofbolting as a system of support. Notable success with Australian Technology was achieved at different British coal mines.

Siddall and Gale (1992) concluded that the systematic introduction of roofbolting and willingness by British mining engineers to accept it has also contributed to the success of this method of roadway stabilisation. Recent advances in computer technology and advances in rock testing equipment and methods have provided the opportunity to simulate ground behaviour under various conditions. Computer simulation techniques will in the future be used to assist in the design of mine pillars, to assess mine layouts using certain roadway stabilisation methods and to design bolting systems in both current areas and greenfield sites.

2.5 Conclusions

The literature review showed that three main rock reinforcement techniques have been developed since the introduction of roofbolting in mining applications - beam building, suspension and rock strengthening.

While the beam building and suspensions modes are applicable in conditions where the stresses and deformations are relatively small, rock strengthening is mainly applicable where deformations and stresses are high.

In South Africa and the US, support design is most commonly based on beam building and suspension, while for Australian and UK conditions the rock strengthening technique is used. Underground roof monitoring results showed that South African roof behaviour is characterized by low deformation. This indicates that, in most instances, the roof fall failure mechanism may not be related to high horizontal stresses, but rather due to simple gravity loading. In Australia and the UK the dominant factor causing roof falls is very high horizontal stress.

While beam building designs are based on empirically based calculations, rock reinforcement or strengthening is based on in situ monitoring and numerical modelling. However, extensive studies by Vervoort showed that the material properties used as input parameters in numerical modelling can affect the results significantly. Using the wrong parameters will give completely wrong results, which will affect the design. However, the Australian technique subsequently adapted in the UK has proven that numerical modelling can be used to simulate and back analyse the underground conditions to calibrate the model. Once the model is calibrated, then the results obtained from the numerical models can be used for design.

The stress magnitudes and directions are also found to be very important parameters in the design of roof support. Therefore, extensive stress measurements are recommended when applying the rock strengthening method. Obtaining this information assists the rock engineer with the general design. However, changing conditions underground must be determined and the design has to be modified accordingly. Therefore, not only widespread instrumentation, but also vigilant visual observations are important under these conditions to ensure safety and stability.

The literature review also highlighted the importance of identifying the roof failure mechanisms and then establishing deformation criteria and other visual indications of impending instability that can be used by production personnel to initiate appropriate actions to control the hazard. The introduction of some simple form of roof monitoring in South Africa should assist in establishing a data base and yield very useful information. A cost-effective reliable instrument to assess and visually indicate roof behaviour, such as tell tales could well be the answer.

The literature review also indicated that increasing the density of support is not always the solution to improve stability but rather that the roofbolt pattern is more important. In some cases, increasing the density of support can lead to less stable conditions.

3 Underground monitoring of roof and support behaviour

3.1 Introduction

A prerequisite of this investigation was an accurate reliable instrument capable of monitoring roof behaviour. The most appropriate instrument identified was the sonic probe extensometer.

If the user of an instrument does not have confidence in that instrument, the results obtained will always be suspect and consequently of uncertain value. One of the primary objectives when acquiring any new instrument is therefore to evaluate its abilities and to identify any shortcomings. In order to establish an acceptable confidence level in the sonic probe's monitoring capabilities, a series of tests on surface and underground were carried out to assess its accuracy and performance over a two year period. This resulted in the overall accuracy of the system, under operating conditions, being established at approximately 1.0 mm.

However, some of the results include cases of apparently anomalous behaviour. It is sometimes difficult to differentiate between genuine anomalous readings and what may be termed "unconventional" readings. The unconventional reading is one that, because it does not conform to current understanding, and hence preconceived ideas concerning roof behaviour, could easily be written off as an anomaly. The possibility that these readings could be real should be acknowledged and where possible attempts made to interpret their meaning.

A description of the sonic probe, its operating principals and the variety of tests conducted with it are included in Appendix 2.

In a large proportion of the Australian collieries, the dominant driving force influencing roof behaviour is a high horizontal stress regime. This induces buckling of the roof strata, which results in displacements of tens to hundreds of millimetres depending on the effectiveness of the roof support system installed. At Baal Bone Colliery in New South Wales where the horizontal stress is 16 to 18 MPa, roof falls up to a height of 6.0 m have occurred. By installing additional support in the form of cable anchor trusses it can be contained although roof skin displacements of up to 500 mm have been recorded.

Not much is known and little quantitative data exists concerning the horizontal stress component in South African collieries. Only a few collieries exhibit any obvious signs of a high horizontal stress regime, which usually takes the form of isolated cases of guttering. Nevertheless, in order to cover as much of the roof strata as possible, and avoid losing what could in time turn out to be valuable information, the full string of 21 anchors with the top anchor at approximately 7.3 m was installed at all the monitoring sites. A total of 29 sites at five collieries were monitored.

To process the monitoring data as quickly and efficiently as possible, a customised program was written in house, culminating in an easy to understand set of graphic results. The basic function of this program is to compare all subsequent sets of readings with the original set and produce displacement-with-time graphs. Various modifications and improvements were introduced to include the option of producing velocity and acceleration graphs to assist with the interpretation of the results.

Appendix 3 consists of a short write up titled "An introduction to the interpretation of sonic probe graphs". The purpose of Appendix 3 is to assist those not familiar with extensometer results, in particular with sonic probe graphs and their interpretation, in understanding them. For this reason the explanations have been kept fairly simple.

3.2 Underground monitoring procedure

To record all the information relevant to roof strata deformation prior to the installation of any roof support would necessitate the installation of instrumentation a few metres ahead of the face. Since this is clearly not possible the next best scenario is to install the instrumentation at the face. However, due to practicalities such as not working under unsupported roof and the limitations on how close machines such as roof bolters can get to the face, it is not usually possible to drill closer than about 0.5 m from the face. This results in the monitoring hole being in or close to the last row of support.

To minimise the disruptive effects of the instrumentation installation program on the underground production cycle, arrangements were made whereby the majority of the monitoring sites were pre-prepared. This enabled the underground personnel to utilise their labour and equipment when it best suited them. Ideally, on the instrumentation teams arrival underground in the section, the site would be cleaned, the support would be as close to the face as possible and the drilling team and equipment would be available at short notice.

Drill bit sizes, resin quantities and support types and lengths could be monitored, as they were usually present at the face. The support type and installation details, as presented alongside each sonic probe graph, indicate the ideal situation or textbook installation. In the underground situation the quality of roof support installation is dependent on a number of factors. With resin bonded bolts the bond length and quality are dependent on the actual average hole diameter, the overdrilling of holes and deviations from the recommended resin spin and hold times. It was not practical or possible to monitor or control the support installation at the monitoring sites. The support performance monitored is therefore a true representation of the support systems as installed underground and includes any effects linked to imperfections in the installation of the support.

At the monitoring site, close to the face, and situated in the middle of the advancing roadway, an 8.0 m deep hole was drilled vertically with a roofbolter into the roof and reamed out to 50 mm in diameter to accommodate the sonic probe magnetic anchors. Although most of the drilling process is carried out with water flushing, the final reaming of the hole is done dry, as the modified custom made reaming bits cannot accommodate water channelling. The hole was cleaned by inserting a water hose to the top or by spinning one of the smaller drill bits up the hole with the water switched on. A petroscope was then inserted into the hole and the lower 2.5 m was examined to detect the presence of any open cracks or fractures.

A full string of 21 anchors was then installed at predetermined intervals using a set of installation rods. The top anchor, the first to be installed, is placed at approximately 7.3 m. An extra anchor that does not have a magnet fitted is installed close behind the last anchor, a short distance into the collar of the hole. This is a prerequisite in a vertical hole and is used to suspend the sonic probe to prevent it moving during the reading process.

Depending on the mining method and speed of face advance, the time lapse between further sets of readings varied from hours to days apart. In a typical development section underground three or four sites close to the centre of the panel were monitored. Ideally, the sites included both roadways and intersections to be able to evaluate and compare the strata behaviour and support performance in the two different locations. Prior to any development of the intersection taking place, the instrumented hole was positioned at the face so as to be as close as possible to the centre of the proposed intersection.

Survey levelling was used in conjunction with the sonic probe to assist in assessing the accuracy of the probe. The relative displacement measured between points anchored at 0.1 m in from the roof skin and at an elevation of approximately 1.8 m should ideally be compared against displacements measured between anchors at similar elevations by the sonic probe. However, at most of the monitoring sites where levelling was implemented, all the roof displacements took place within 1.8 m of the immediate roof. For the sake of simplicity the

levelling results have therefore been compared with the “total relaxation” measured by the sonic probe. The total relaxation is the overall displacement between a stable elevation in the roof and the anchor closest to the roof skin. In the five cases (Colliery D area two) where displacements occurred up to 2.5 m into the roof, a note concerning the comparative probe and levelling displacement values has been included in the appropriate figures. These values have also been included in Table 3.1 where direct comparisons can be made between the sonic probe results and all the sites where back up levelling was successfully implemented.

In some cases it was not possible to make use of the survey levelling backup system due to factors such as the dip of the seam and the mining method and sequence. Levelling monitoring points that were damaged during the monitoring period have been excluded from the results. Levelling backup was successfully implemented at approximately half the monitoring sites. The survey levelling results have been included in the sonic probe displacement graphs. In excess of 90 per cent of the cases, the levelling results recorded similar or higher values than those of the sonic probe. A higher value levelling result is perfectly acceptable since the levelling skin anchor is usually about 0.1 m closer to the roof skin than the lowest sonic probe anchor. Any displacement that occurs between their respective elevations would only be recorded by the levelling results.

3.3 Processing of information

After an installation was complete the initial readings were taken. These comprise a minimum of three sets which were screened for any obvious anomalies or booking errors. They were then entered into the program where they were averaged, and the calculations carried out to produce the graphic results necessary for interpretation. All the subsequent sets of readings were treated in a similar manner with the program comparing them to the first (datum) set of readings from which the displacements were calculated.

In excess of 80 per cent of the monitoring sites all displacements in the roof were confined to the lowermost 2.5 m roof strata. The original displacement graphs included all the anchors in the hole up to the 7.3 m elevation and were in the same format as those presented in Appendices 2 and 3. However since the main focus of the investigation was in the vicinity of the support horizon all the support performance graphs have been cropped at the 2.5 m elevation. This does not infer that displacements above the 2.5 m elevation are being discarded or ignored. Those sites where there were indications of displacements above the 2.5 m elevation have a reference to this effect included in the individual support performance graph notes.

Included alongside the 2.5 m vertical axis on each graph is a shaded block representing the section of strata column under investigation. The patterns within the block represent the approximate positions of the different strata types, typically sandstone, shale and coal. These patterns are included and labelled in Figure 3.1. The stratigraphic column included with each individual displacement graph is representative of the area under investigation. It is not site specific as it was not possible to drill cored boreholes at each site with the drilling equipment available. Although in some cases as many as 15 site visits were carried out and sonic probe readings taken, individual composite graphs have been limited to a maximum of five sets of readings for reasons of clarity.

In order to present the results of the individual site investigations in as simple and efficient a manner as possible, a graphic classification system has been developed. An explanation of this system and the relevance of other information included with it is given in Figure 3.1.

Although the displacements usually start at the roof skin and are evident for some distance into the roof, the section of the strata column under investigation does not extend down to the roof skin. The reason for this is that the bottom magnetic anchor of the anchor string has to be approximately 0.2 m into the roof to allow the dummy anchor, used as a suspension point for the sonic probe, to be installed behind it.

Table 3.1. Sonic probe, levelling and stable roof elevation results

Colliery and Roof strata	Mining method	Support type	Monitoring Position	Probe relaxation (mm)		Levelling (mm)		Stable roof elevation	
				Total	Averages	1.8 m - skin	1.8 m - skin	(m)	Averages
A Shale	C M	Full column resin	Roadway	2.5	1.3	2.5		1.1	
			Roadway	0.0		0.0		0.0	0.6
B Coal roof 0.3 m shale then coal above	D&B	Partial column resin	Roadway	2.0		1.2		2.2	
			Roadway	0.5		0.5	1.0	2.0	
			Roadway	2.5		2.3	2.5	2.0	
			Roadway	3.0	2.0	3.0	4.2	2.2	2.1
			Intersection	4.0	5.0	3.8		2.0	
			Intersection	6.0		6.0		2.0	2.0
C 0.3m coal with shale above	D&B	Mechanical end anchored	Roadway	1.5		1.5		2.5	
			Roadway	0.5	1.0	0.5	1.5	1.9	2.2
			Intersection	3.5		3.5	5.7	1.9	
			Intersection	1.0	2.3	1.0		2.2	2.1
D Inter laminated sandstone and shale	D&B Area 1	Full column resin	Roadway	0.5		0.5		1.4	
			Roadway	1.0	0.8	1.0	1.0	1.1	1.3
			Intersection	6.5		6.5	7.0	1.4	
	C M Area 2	Partial column resin	Intersection	2.5	4.5	2.5	4.0	1.9	1.7
			Roadway	2.5	2.5	2.0	3.7	2.0	2.0
			Intersection	2.0		2.0		1.8	
E Sandstone	C M Area 3	Full column resin	Intersection	12.0		11.5	11.2	2.5	
			Intersection	12.0		9.5	12.5	2.5	2.2
			Intersection	6.0	8.0	5.0	10.0	1.9	
			Roadway	1.0		1.0		0.8	0.9
			Roadway	0.5	0.8	0.5		1.0	1.2
			Intersection	1.0	1.0	1.0		1.2	0.1
	C M	Full column resin	Roadway	1.0	0.2	1.0		0.5	
			Roadway x 4	0.0		0.0		0.0	0.1

The displacements recorded by the final set of sonic probe readings taken at a particular site are transferred to the strata column. Here they are shown as individual lines approximately midway between the anchors from which each relative displacement value was calculated.

In order to establish a uniform approach to assist in simplifying the interpretations, the following criteria were introduced:

- Only readings outside the accepted error band were accepted.
- Differential displacements between adjacent anchors had to exceed 0.5 mm to be considered, except in the case of a trend involving three or more anchors where displacements down to 0.25 mm were included.
- Only “kickbacks” (see Appendix 3 Figure 4) below the estimated stable elevation were included. The reasoning was that the higher up in the anchor string they occurred the more likely they were to be anomalous readings.

Displacements of 0.25 mm and larger are therefore represented by a line. In order to emphasize the different magnitudes of the various displacement zones, each line has been designated an appropriate thickness proportional to the value. These lines represent the total displacement recorded within the zone (between the two anchors) and do not infer that all the displacement took place at one particular elevation or parting plane; they are primarily an indication of relative magnitudes.

In Figure 3.1, to assist in explaining this concept, the anchor string showing individual anchor elevations has been included. Alongside each displacement line the individual displacement values have been recorded. Where no displacement was observed, a zero value (0.0) is evident, as is the lack of a displacement line. The method used to indicate a negative displacement or kickback is also indicated. An appropriate thickness proportional to the value also applies to the kickback indicator. The anchor string and displacement values have been included in Figure 3.1 primarily to assist with the explanation. They are not recorded in the graphic presentations of the individual monitoring site figures, as this information is already present in a slightly different form in the sonic probe graph.

To assist in assessing the effectiveness of the various roof support systems, a single support member is also included as part of the shaded strata column block alongside each sonic probe graph. The length of both the support member and the anchoring mechanism is drawn in at the same scale as the vertical axis of the sonic probe graph. A partial column resin anchored bolt is shown in Figure 3.1.

The roof displacements measured by the sonic probe are superimposed on the relevant roof support member for comparison purposes. This does not necessarily infer that these displacements are occurring in or at the support tendon hole, particularly where the hole is full of resin. The sonic probe hole varied between 0.3 to 1.0 m away from the closest support tendon hole.

The anchor height above which no displacements were recorded in a strata column is indicated as the ‘stable elevation’. In cases where some doubt exists it may be referred to as the ‘estimated stable elevation’. The ‘total relaxation’ value indicates the overall displacement between the stable elevation and the bottom anchor in the string. In the case of a kickback (refer to Appendix 3) close to the roof skin, the displacement of one or more anchors above the bottom anchor could exceed the ‘total relaxation’ value. The reason for using the bottom anchor value is because it is the anchor closest to the roof skin and, where applicable, can be compared with the levelling skin anchor backup information.

Included with each displacement graph is a list of notes covering the monitoring site position, layout and mining method as well as a description of the roof strata and support system installed.

A phenomenon that initially occurred in the immediate vicinity of the roof skin in approximately 30 per cent of the monitoring sites is the so called kickback, a typical example of which is presented in Appendix 3, Figure 4. When first encountered, this phenomenon, of anchors apparently moving towards each other, was thought to be an anomaly introduced as a result of the mathematics involved in transposing the fixed reference point from the bottom anchor to the top anchor in the hole.

The sonic probe measures the distance to each anchor relative to the reference anchor, which is the anchor closest to the collar of the hole. However, for graphical interpretation the computer program assumes the top anchor to be static, makes it the reference point, and then calculates the position of all the other anchors in the string relative to it. If there is a drift in the string of readings, similar to tape measurements taken where the zero does not exactly coincide with the reference point, the measurement to each anchor is offset by a similar value. Because the offset value is common to all the anchor measurements, it is eliminated in all but one of the re-positioning calculations. The exception is the anchor closest to the collar of the hole. In this case, any offset value, which may be included in the measurement between the first and last anchors cannot be eliminated in a calculation and is assumed to be a true and accurate measurement.

Another option considered, which is applicable to any anchor position in the hole, is the possibility of a genuine anomalous reading. If such a reading were present in the original or datum set of readings, all the subsequent sets of readings would be affected and offset by a similar amount.

As the size of the database increased and more examples of kickbacks began to emerge, other possible explanations were explored. There appears to be a link between the kickback observation and certain roof strata types such as shale and coal. At one colliery in particular, kickbacks were evident some distance into the roof, not only, or necessarily, in the immediate vicinity of the roof skin. A possible explanation could be the shrinkage of certain soft roof strata types through drying out when exposed to ventilation. Another explanation could be the presence of pre-existing open partings in the roof prior to the installation of the support and instrumentation. The later closure of these partings through beam separation and deflection could result in anchors moving towards each other. This relative movement would manifest itself as a kickback in the sonic probe graph.

A fifth possibility is, if there is an increase in the compressive stress along the axis of the monitoring hole, the induced compressive strain changes can shorten the distance between anchors. However, in the tensile region of the immediate roof of an excavation these conditions do not exist.

When examining the results recorded up to the 2.5 m elevation into the roof strata, kickbacks were observed in approximately 45 per cent of the monitoring sites.

Kickbacks have also been recorded in Australian collieries close to the roof skin. The physical values, usually less than 10 mm, are similar to those experienced locally. However, in Australia, in most cases where the sonic probe is used, displacements of tens to hundreds of millimetres are measured, an order of magnitude higher than in South Africa. The magnitude of the displacements when plotted on a graph tends to overshadow any kickbacks and little attention is paid to them. In common with our local computer program, the Australians also use a similar mathematical process to convert the measurements relative to a reference anchor at the top of the hole.

3.4 Colliery 'A'

Two sites, both in the same roadway 43 m apart, were monitored at colliery 'A'. There were indications of the presence of a high horizontal stress regime in the section. Guttering on one side of the roof/sidewall contact appeared to develop one or two pillars back from the face in roadways travelling in the same direction as the roadway where the monitoring sites were installed. Although in some cases the guttering was semi continuous for two or three pillars its general appearance appeared to be random in nature. A number of intersections had collapsed and some roadways had been barricaded off due to dangerous roof conditions, usually associated with the guttering. Petroscope holes, drilled into the roadway roof where there were obvious roof problems, detected displacements up to a height of 1.6 m into the roof. Within this zone a number of openings in excess of 10 mm were observed.

The colliery was situated in the Vereeniging coalfield mining the 2B Seam at a depth of 70 to 80 m with a mining height of 3.0 m. Mining was carried out using a continuous miner with onboard roof bolters. The roof was shale supported by 2.1 m long AX bars 21 mm in diameter with full column resin in a 25 mm diameter hole. The 5.0 m wide roadways were supported with five to six bolts per row with 'W' straps. The rows were 1.0 m apart.

The monitoring results from the two holes are presented in Figures 3.2 and 3.3. These results did not conform to what was expected. The monitoring hole installation positions relative to the face were governed by how close the continuous miner with its onboard roof bolters could get to the face. Face advances in excess of 60 m took place during the two month monitoring period. At site one (Figure 3.2) displacements were only recorded below the 1.1 m elevation. The total relaxation of the lowest anchor was 2.5 mm bearing in mind that this displacement is relative to the stable elevation. At site two (Figure 3.3) no displacements were detected.

The sonic probe was immediately regarded with suspicion. A series of tests carried out in the test rig during the monitoring period indicated that the sonic probe was performing satisfactorily. Unfortunately it was not possible to install the survey levelling backup system at either site. Towards the end of the monitoring period, a petroscope hole was drilled close to each sonic probe hole up to a depth of 2.5 m into the roof. Examination of these holes indicated that little if any displacements had occurred thereby confirming the sonic probe results.

There was no visual evidence at either of the two sites to indicate the presence of a high horizontal stress regime. This experience illustrates the site specific nature of each monitoring site. The support system installed was more than adequate to control the shale roof in the regions where it was not subjected to the buckling effects of a high horizontal stress regime. Unfortunately it was not possible to repeat the monitoring exercise in the hope of selecting a site that would later be subjected to the effects of a high horizontal stress.

3.4.1 Site performance summary colliery 'A'

Coalfield	: Vereeniging	Seam	: 2b		
Sites	: Two	Positions	: Roadway		
Road widths	: 5.0 m	Pillar widths	: 24 x 48 m	Mining height	: 3.0 m
Depth	: 70 to 80 m	Mining method	: Continuous miner, onboard roof bolters		

Roof strata : Shale

Support : 2.1 m x 21 mm AX bar, full column resin in 25 mm hole
Five to six bolts per row 1.0 m apart with "W" straps

Performance : Although there were indications of the presence of high horizontal stress within the section, there was no visual evidence to indicate its development at either monitoring site. The roof loading mechanism was therefore assumed to be predominantly gravitational.

The support was adequate. Roof separation was only measured at one site up to a maximum of 1.1 m into the shale allowing the roof skin a total relaxation of 2.5 mm after a face advance of 66 m over a 66 day period.

3.5 Colliery 'B'

Six sites, four in roadways and two in intersections, were monitored at colliery 'B'. Of the five collieries where roof monitoring was carried out, only colliery 'B' exhibited the apparently wild unconventional results, at all six monitoring sites, presented in Figures 3.4 to 3.9. The initial reaction to these results was one of doubt that the sonic probe was functioning properly. Another possible explanation initially considered was that the first set of readings, the so-called datum readings, were flawed and had errors in them.

Closer investigation suggests that this would be highly unlikely to occur in all six cases, particularly as on two separate occasions the initial readings at two new sites were taken within hours of repeat readings at an existing site. In area one the installation and initial readings of sites two and three were taken on the same day as reading B (day four) at site one. Similarly, in area two the installation and initial readings of sites two and three were taken on the same day as reading B (day six) at site one. The monitoring at area two, was carried out six months after the monitoring at area one. During the monitoring period at area two, monitoring was also taking place at colliery 'D' area two. The results of the monitoring at colliery 'D' area two produced completely different profiles to those of colliery 'B'. Thus no drift or other malfunction in the measuring system was proved.

Three weeks after completion of the monitoring at area one and again one week prior to the start of monitoring at area two, test rig results indicated that the sonic probe was performing satisfactorily.

At three of the six monitoring sites, backup levelling was installed and monitored in conjunction with the sonic probe investigation. At all three sites, as is evident in Figures 3.4, 3.6 and 3.8, the levelling results agreed very closely with, and confirmed the final position and displacements of the sonic probe anchor closest to the collar of the hole at various stages during the monitoring period. This levelling confirmation of the overall total relaxation measured between the 1.7 to 1.8 m horizon and 0.1 m into the roof skin includes kickbacks at various elevations at all three sites.

All this evidence suggests that these six sets of results, however wild and unconventional they appear to be, are real and reflect what is happening within this particular roof strata.

The immediate roof strata consists of 0.5 to 1.0 m of coal, followed by a shale band approximately 0.3 m thick above which there is a further 3.0 m of coal. In the figures the 'typical' roof strata profile shows a shale band 0.3 m wide positioned at 0.7 m to 1.0 m into the roof. As previously emphasised, on a site specific basis the exact thickness and position of the shale band are not known. When comparing the six sonic probe graph results against the 'typical' strata column section, this unknown shale band elevation should be borne in mind.

Monitoring of the first three sites at area one, an intersection and two roadways, was carried out to establish the characteristics of the particular strata combination and support performance. The opportunity to do additional monitoring at area two came about as the result of a dyke. In adjacent sections of the mine, separated by a dyke, there appeared to be differences in the competency of the roof although the roof strata were similar. Again an intersection and two adjacent roadways were monitored. There was a slight difference in the mining sequence at area two site three where the roadway was only advanced 3.0 m before being holed into from the opposite direction.

**Section of strata column
under investigation**

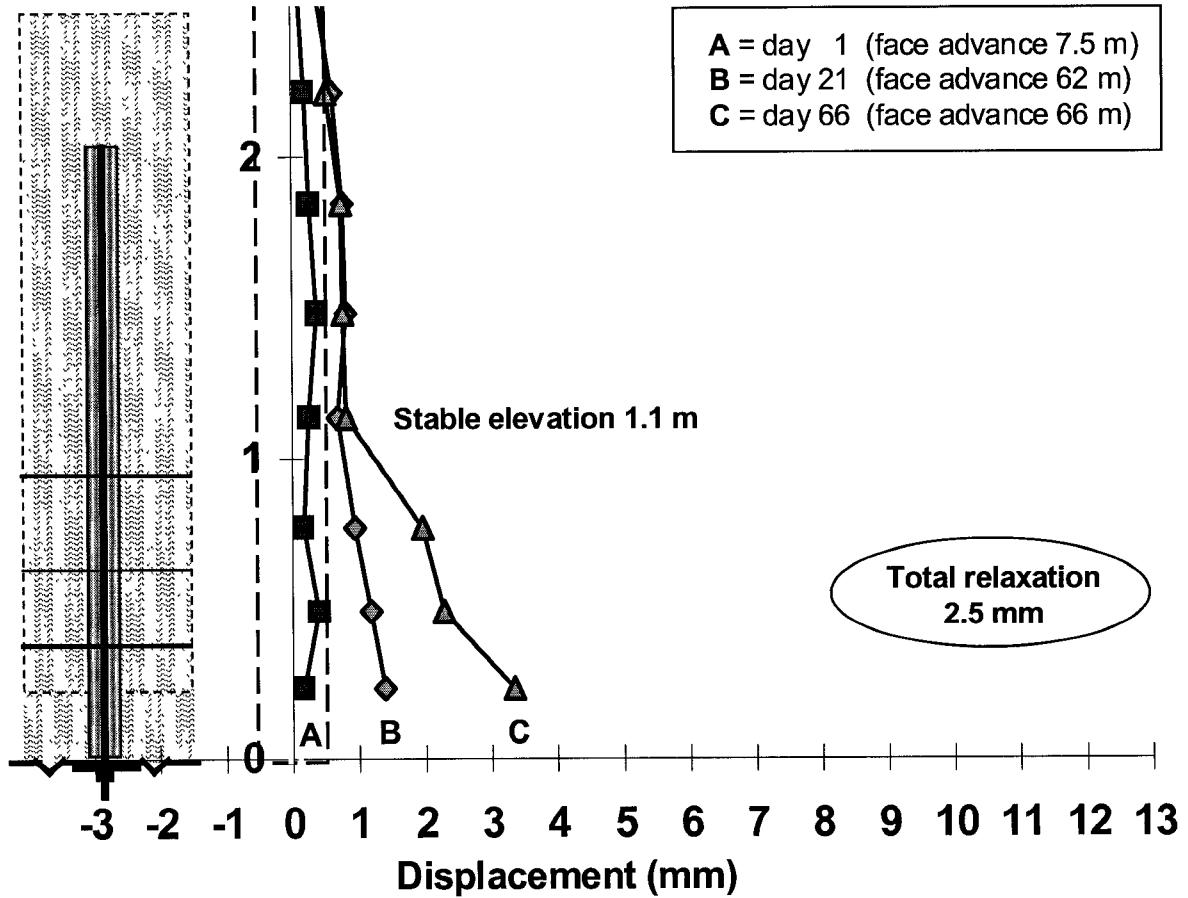

Notes

Coalfield :Vereeniging **Seam 2b** **Position** Roadway

Roof : Shale

Support : 2.1 m AX bar 21 mm diameter with full column resin in a 25 mm diameter hole. Five to six bolts per row 1.0 m apart with 'W' straps.

Layout : **Depth** 70 to 80 m **Bord** 5.0 m **Pillar** 24 x 48 m **Mining height** 3.0 m

Mining : Continuous miner with an onboard roof bolter.

Although there were indications of the presence of high horizontal stress within the section there was no visual evidence to indicate its development at this particular monitoring site.

Figure 3.2. Colliery 'A' site 1 (bord)

**Section of strata column
under investigation**

Legend

Day 1 installation at 2.2 m

- A** = day 17 (no face advance)
- B** = day 23 (face advance 21 m)
- C** = day 52 (face advance 74 m)

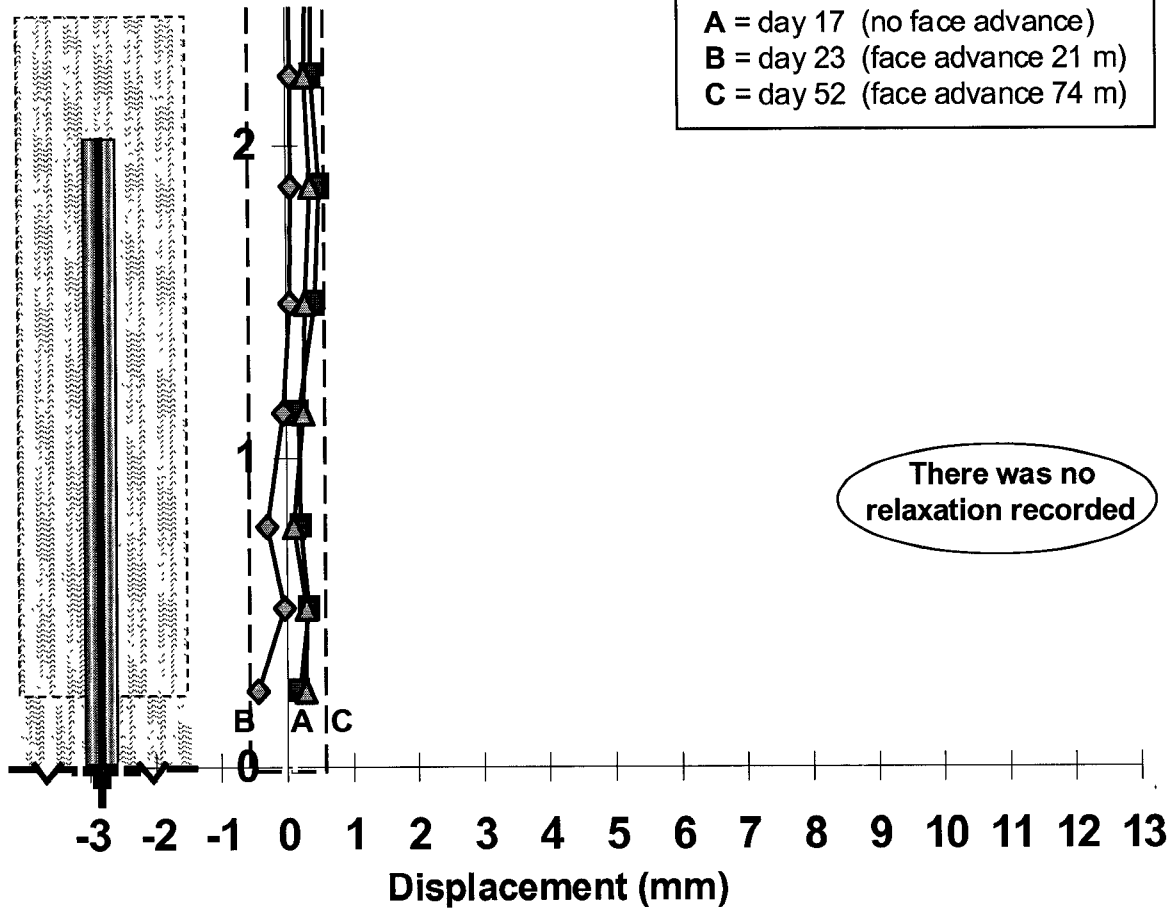

Notes

Coalfield : Vereeniging **Seam 2b** **Position** Roadway

Roof : Shale

Support : 2.1 m AX bar 21 mm diameter with full column resin in a 25 mm diameter hole. Five to six bolts per row 1.0 m apart with 'W' straps.

Layout : **Depth** 70 to 80 m **Bord** 5.0 m **Pillar** 24 x 48 m **Mining height** 3.0 m

Mining : Continuous miner with an onboard roof bolter.

Although there were indications of the presence of high horizontal stress within the section there was no visual evidence to indicate its development at this particular monitoring site.

Figure 3.3. Colliery 'A' site 2 (bord)

Section of strata column under investigation

Legend

Day 1 installation at 0.7 m

- A = day 2 (face advance 3 m)
- B = day 4 (face advance 8 m)
- C = day 10 (face advance 25 m)
(splits holed)
- D = day 48 (face advance 120 m)

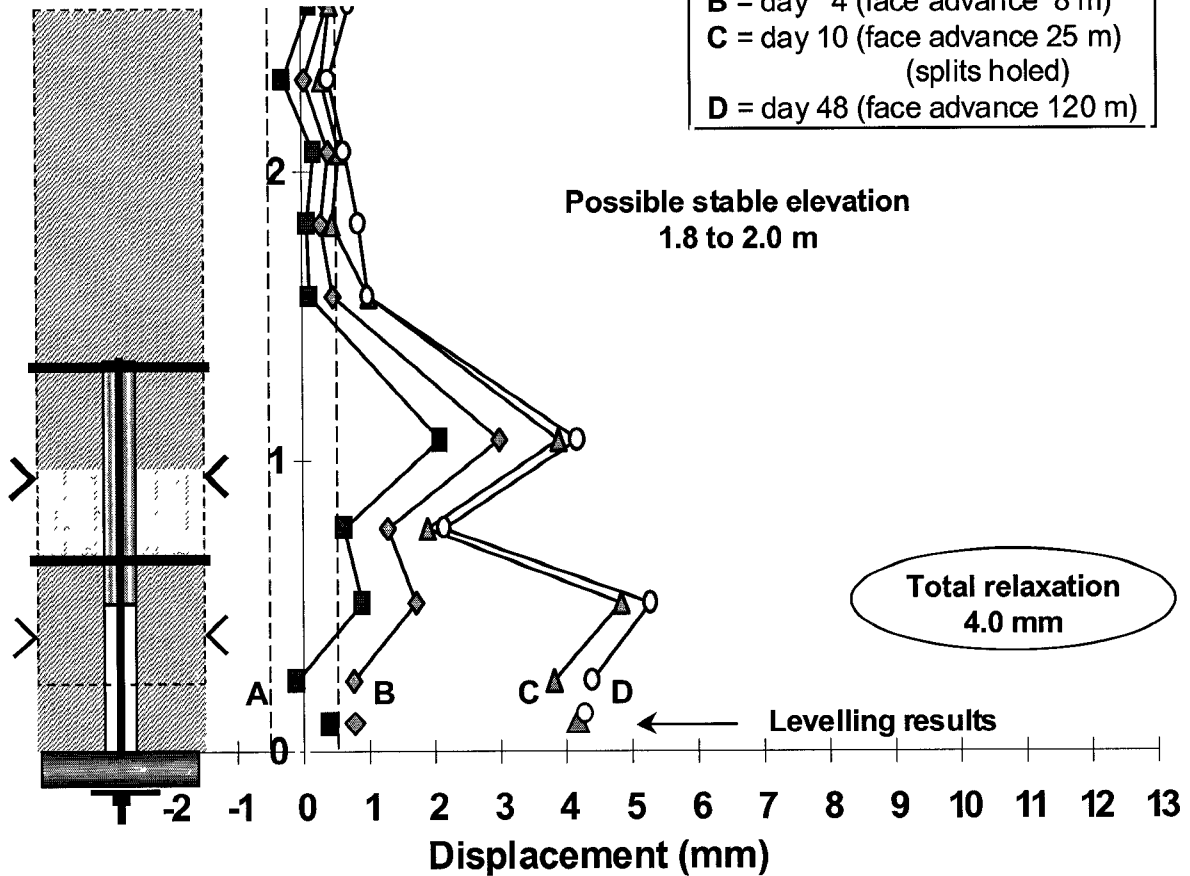

Notes

Coalfield : Witbank **Seam** 2 seam **Position** Intersection

Roof : 0.5 to 1.0 m coal, 0.3 m shale then coal to approximately 4.0m.

Support : 1.5 m x 16 mm diameter 'V' bar with partial column resin in a 24 mm diameter hole with 0.1 x 0.1 x 0.9 m headboards. Two bolts 4.0 m apart with 3.0 m between rows. Halfway between these rows is a single centre bolt in a dice five pattern.

Layout : Depth 40 m **Roadway** 6.0 m **Pillar** 9.0 m **Mining height** 3.0 m

Mining : Conventional drill and blast.

The major displacements appear to extend to just above the bolt horizon.
Two kickbacks below the 1.0 m elevation indicate total closure of 3.0 mm

Figure 3.4. Colliery 'B' area 1 site 1 (intersection)

**Section of strata column
under investigation**

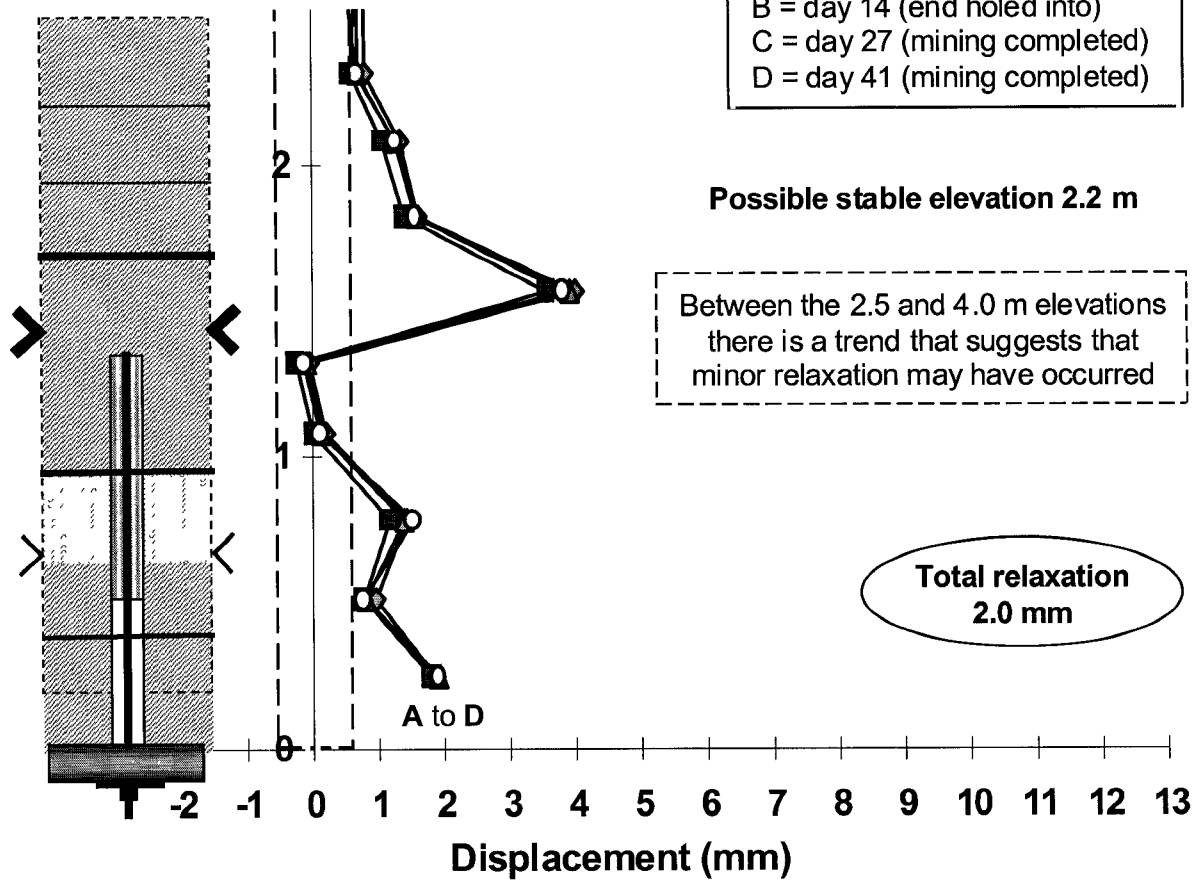

Notes

Coalfield : Witbank **Seam** 2 seam **Position** Roadway

Roof : 0.5 to 1.0 m coal, 0.3 m shale then coal to approximately 4.0 m.

Support : 1.5 m x 16 mm diameter 'V' bar with partial column resin in a 24 mm diameter hole with 0.1 x 0.1 x 0.9 m headboards. Two bolts 4.0 m apart with 3.0 m between rows. Halfway between these rows is a single centre bolt in a dice five pattern.

Layout : Depth 40 m **Roadway** 6.0 m **Pillar** 9.0 m **Mining height** 3.0 m

Mining : Conventional drill and blast.

The major displacements extend up to the 2.2 m elevation, 1.0 m above the bolt horizon. A large kickback of 4.0 mm is situated just above the bolt horizon with a minor one within the bolt horizon. The total closure indicated by these two is 5.0 mm

Figure 3.5. Colliery 'B' area 1 site 2 (roadway)

**Section of strata column
under investigation**

Legend

Day 1 installation at 0.5 m

- A = day 5 (face advance 10 m)
- B = day 11 (face advance 23 m)
- C = day 22 (face advance 42 m)
- D = day 42 (face advance 112 m)

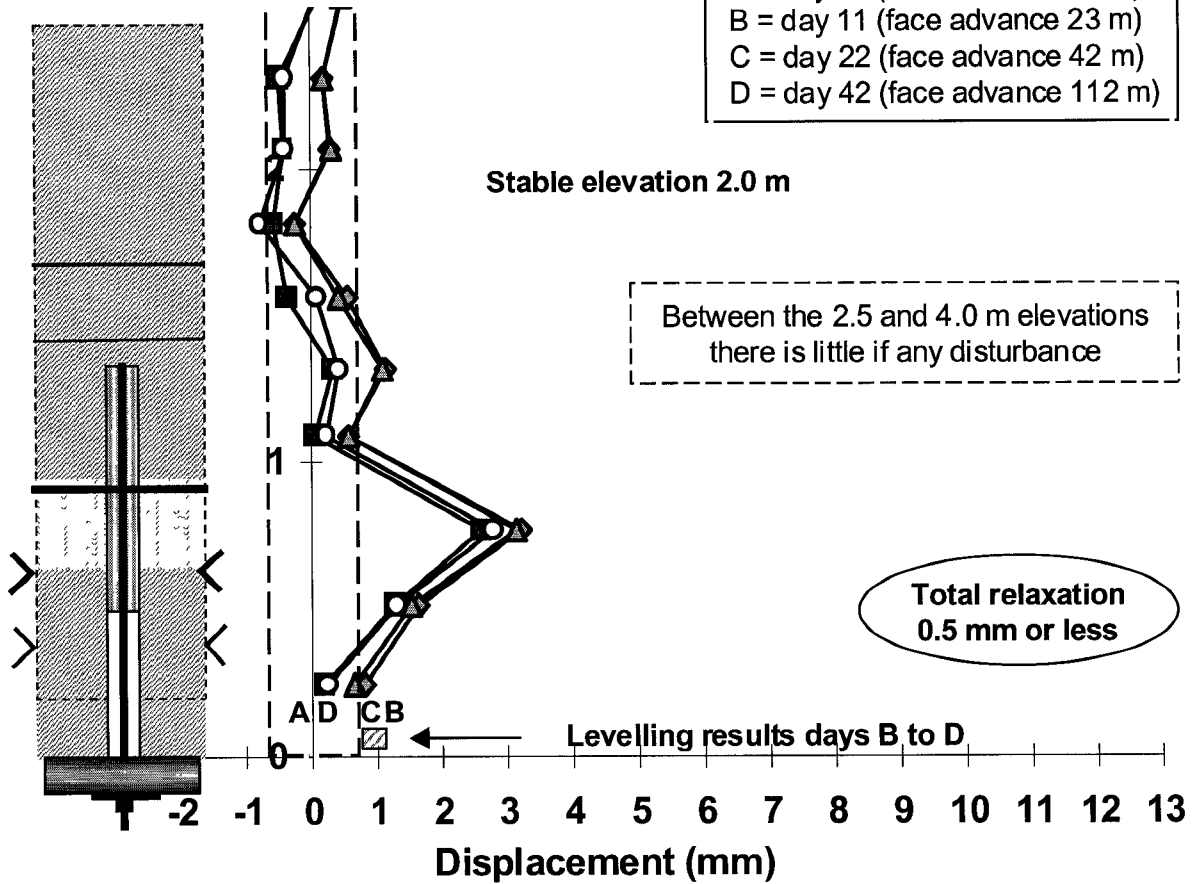

Notes

Coalfield : Witbank **Seam** 2 seam **Position** Roadway

Roof : 0.5 to 1.0 m coal, 0.3 m shale then coal to approximately 4.0 m.

Support : 1.5 m x 16 mm diameter 'V' bar with partial column resin in a 24 mm diameter hole with 0.1 x 0.1 x 0.9 m headboards. Two bolts 4.0 m apart with 3.0 m between rows. Halfway between these rows is a single centre bolt in a dice five pattern.

Layout : Depth 40 m **Roadway** 6.0 m **Pillar** 9.0 m **Mining height** 3.0 m

Mining : Conventional drill and blast.

The major displacements appear to extend up to about 0.5 m above the bolt horizon. Two kickbacks are evident within the first 0.7 m of the roof indicating total closure of 2.5 mm.

Figure 3.6. Colliery 'B' area 1 site 3 (roadway)

**Section of strata column
under investigation**

Legend

Day 1 installation at 0.6 m

- A** = day 2 (face advance 4 m)
- B** = day 6 (face advance 7 m)
- C** = day 7 (face advance 9 m)
(split holed)
- D** = day 8 (face advance 14 m)
(split holed)

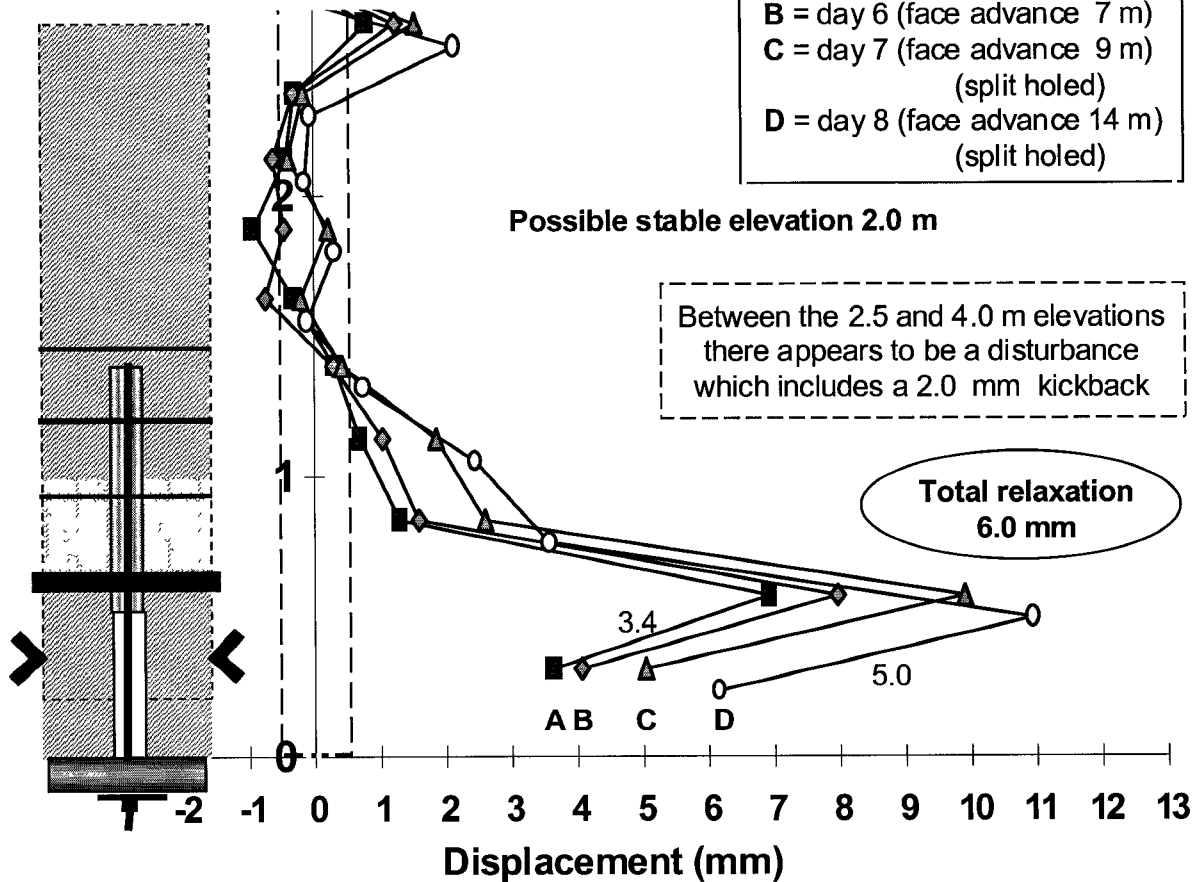

Notes

Coalfield : Witbank **Seam** 2 seam **Position** Intersection

Roof : 0.5 to 1.0 m coal, 0.3 m shale then coal to approximately 4.0 m.

Support : 1.5 m x 16 mm diameter 'V' bar with partial column resin in a 24 mm diameter hole with 0.1 x 0.1 x 0.9 m headboards. Two bolts 4.0 m apart with 3.0 m between rows. Halfway between these rows is a single centre bolt in a dice five pattern.

Layout : Depth 40 m **Roadway** 6.0 m **Pillar** 9.0 m **Mining height** 3.0 m

Mining : Conventional drill and blast.

The major displacements appear to be confined to within 0.2 m above the bolt horizon. A large kickback which increased from 3.4 mm on day 2 to 5.0 mm on day 8 is evident in the first 0.5 m of roof strata. There may be another kickback at the 2.5 m elevation, interpretation of which could be difficult.

Figure 3.7. Colliery 'B' area 2 site 1 (intersection)

**Section of strata column
under investigation**

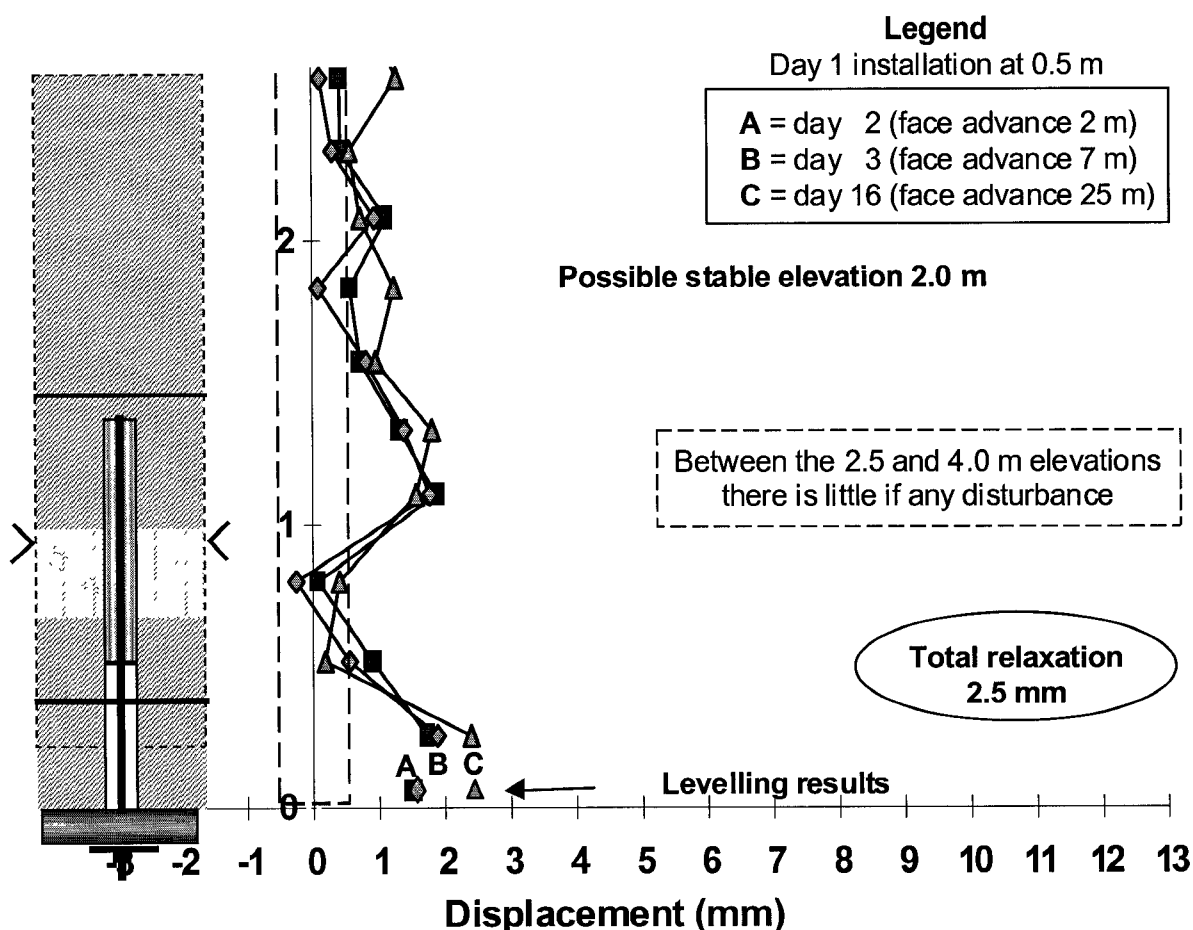

Notes

Coalfield : Witbank **Seam** 2 seam **Position** Roadway

Roof : 0.5 to 1.0 m coal, 0.3 m shale then coal to approximately 4.0 m.

Support : 1.5 m x 16 mm diameter 'V' bar with partial column resin in a 24 mm diameter hole with 0.1 x 0.1 x 0.9 m headboards. Two bolts 4.0 m apart with 3.0 m between rows. Halfway between these rows is a single centre bolt in a dice five pattern.

Layout : Depth 40 m **Roadway** 6.0 m **Pillar** 9.0 m **Mining height** 3.0 m

Mining : Conventional drill and blast.

The major displacements extend up to the 1.6 m elevation, approximately 0.2 m above the bolt horizon. A kickback of approximately 1.0 mm is situated at the 1.0 m elevation.

Figure 3.8. Colliery 'B' area 2 site 2 (roadway)

Section of strata column under investigation

Legend

Day 1 installation at 0.7 m

- A = day 2 (face advance 3 m)
- B = day 3 (roadway holed through)
- C = day 16 (roadway holed through)

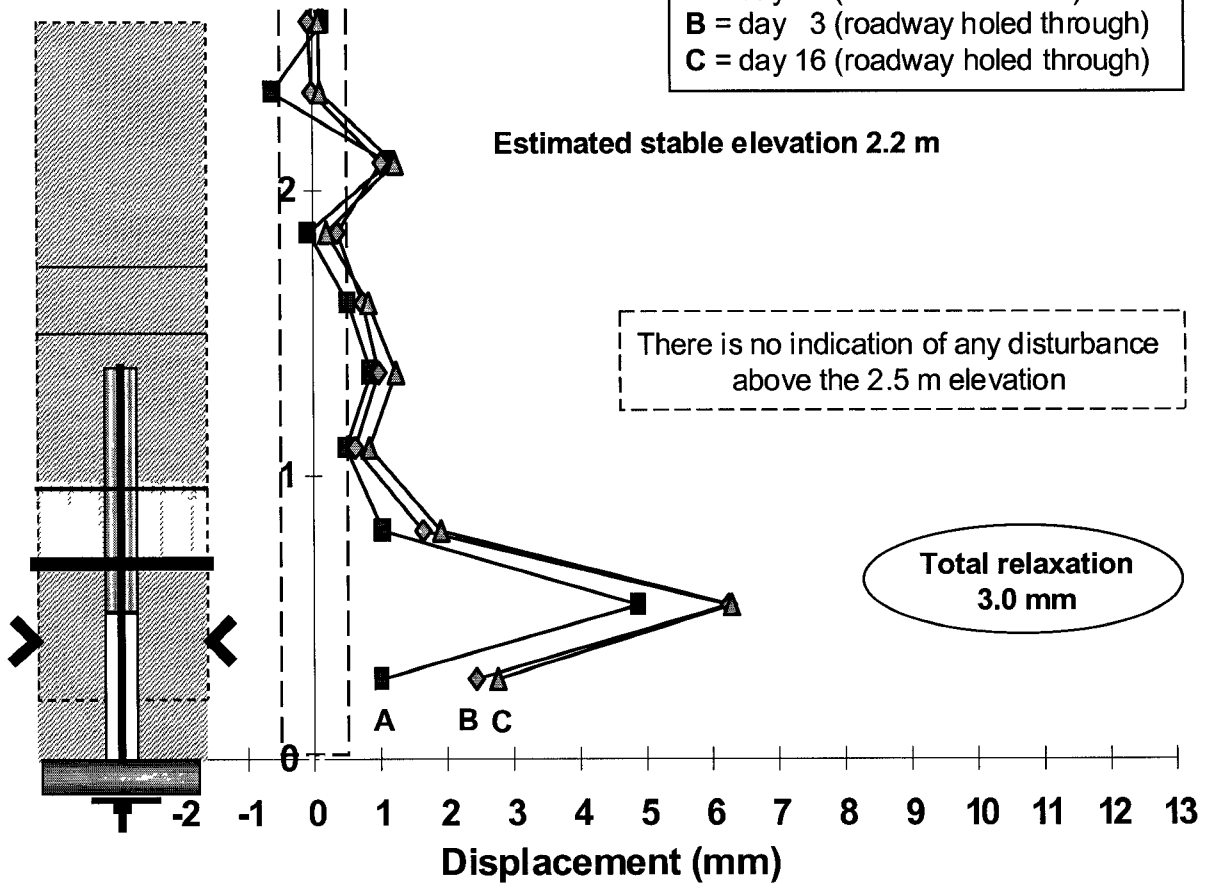

Notes

Coalfield : Witbank **Seam** 2 seam **Position** Roadway

Roof : 0.5 to 1.0 m coal, 0.3 m shale then coal to approximately 4.0 m.

Support : 1.5 m x 16 mm diameter 'V' bar with partial column resin in a 24 mm diameter hole with 0.1 x 0.1 x 0.9 m headboards. Two bolts 4.0 m apart with 3.0 m between rows. Halfway between these rows is a single centre bolt in a dice five pattern.

Layout : Depth 40 m **Roadway** 6.0 m **Pillar** 9.0 m **Mining height** 3.0 m

Mining : Conventional drill and blast.

The major displacements extend up to the 1.9 or 2.2 m elevation. Which is correct depends on the interpretation of whether the apparent kickback at the 2.0 m elevation is real or an anomaly. There is an obvious kickback within the first 0.5 m of roof strata.

Figure 3.9. Colliery 'B' area 2 site 3 (roadway)

At all six sites kickbacks were recorded at a variety of elevations in the roof. As previously mentioned, of the five possible explanations for the occurrence of kickbacks involving the lowest anchor closest to the collar of the hole, four are considered plausible in the prevailing conditions. These are the mathematical error option, a possible anomalous reading in the original set of readings, strata shrinkage and pre-existing open partings. Kickbacks within the roof bolt horizon, but not at the lowest anchor, effectively eliminate the mathematical error option in 50 per cent of the cases. Also taken into consideration was the fact that during all the static tests carried out in the test/calibration rig on surface, no kickbacks were recorded.

With the possibility of a large number of anomalous readings being present in all six sets of original readings being considered highly improbable, this leaves the shrinkage and pre-existing open partings as feasible options. The shrinkage of certain soft strata types, through drying out when exposed to ventilation, is a possibility. There is however no readily available information concerning this phenomenon. Laboratory tests on local shales and coal need to be conducted to establish if the shrinkage values are sufficiently large to account for some, or all, of the kickbacks experienced.

The other possibility is that at the time of the instrument installation there were pre-existing open partings in the roof strata that had occurred close to the face before the support was installed. Consider, for example, an immediate roof skin consisting of a 0.3 m thick beam that had become detached and deflected away from the strata above it, prior to the support and instrument installation. It has a monitoring anchor in it. A thinner or less rigid beam, containing another monitoring anchor, situated immediately above the lower beam, then becomes detached as the face advances. If the support is not capable of preventing it from moving, it would also deflect and probably come to rest against the lower beam. Through the closure of the open parting between the beams, the upper anchor has moved towards the lower one and away from the one above it. This relative movement manifests itself as a kickback on the sonic probe graph. Above each kickback there would also have to be an indication of an opening of at least the same value as the kickback. This basic mechanism is illustrated in Figure 3.10.

At the six monitoring sites there are nine kickbacks in excess of 0.5 mm below the 2.0 m elevation. In all nine cases there is evidence of an opening above the kickback. In approximately 80 per cent of these cases, the value of the opening is the same or greater than the kickback. The remaining cases, in Figures 3.5 and 3.8, have openings slightly less than the kickback values. However, in both cases the displacement trends above and below the kickbacks are fairly well matched which suggests the kickbacks are real although there could be a slight discrepancy in the measured values.

In an attempt to differentiate between the anticipated behaviour of shrinkage and the closing of pre-existing partings options, comparative graph profiles were generated and are presented in Figure 3.11. In the case of shrinkage, through moisture loss, one would expect the rate to be linked to time and ventilation flow as opposed to face advance. In all probability it would start at the roof skin and migrate higher into the roof with time. It would be a gradual process, the rate of which would decrease as drying took place and migration to a higher elevation occurred.

With the pre-existing open parting scenario, displacement would be taking place close to the face. (demonstrated by the suspected existence of an open parting within 1.0 m of the face) A face advance of a few metres could be sufficient to initiate the second cycle where the next beam becomes detached and deflects, creating the kickback. The major portion of the total roof movement would be expected to have taken place by the time the face advance was equal to the roadway width. The slope of the initial displacement on the graph would be steep. In the case where the monitoring site was in an intersection, further displacement would be expected as the span increased as a result of the mining sequence.

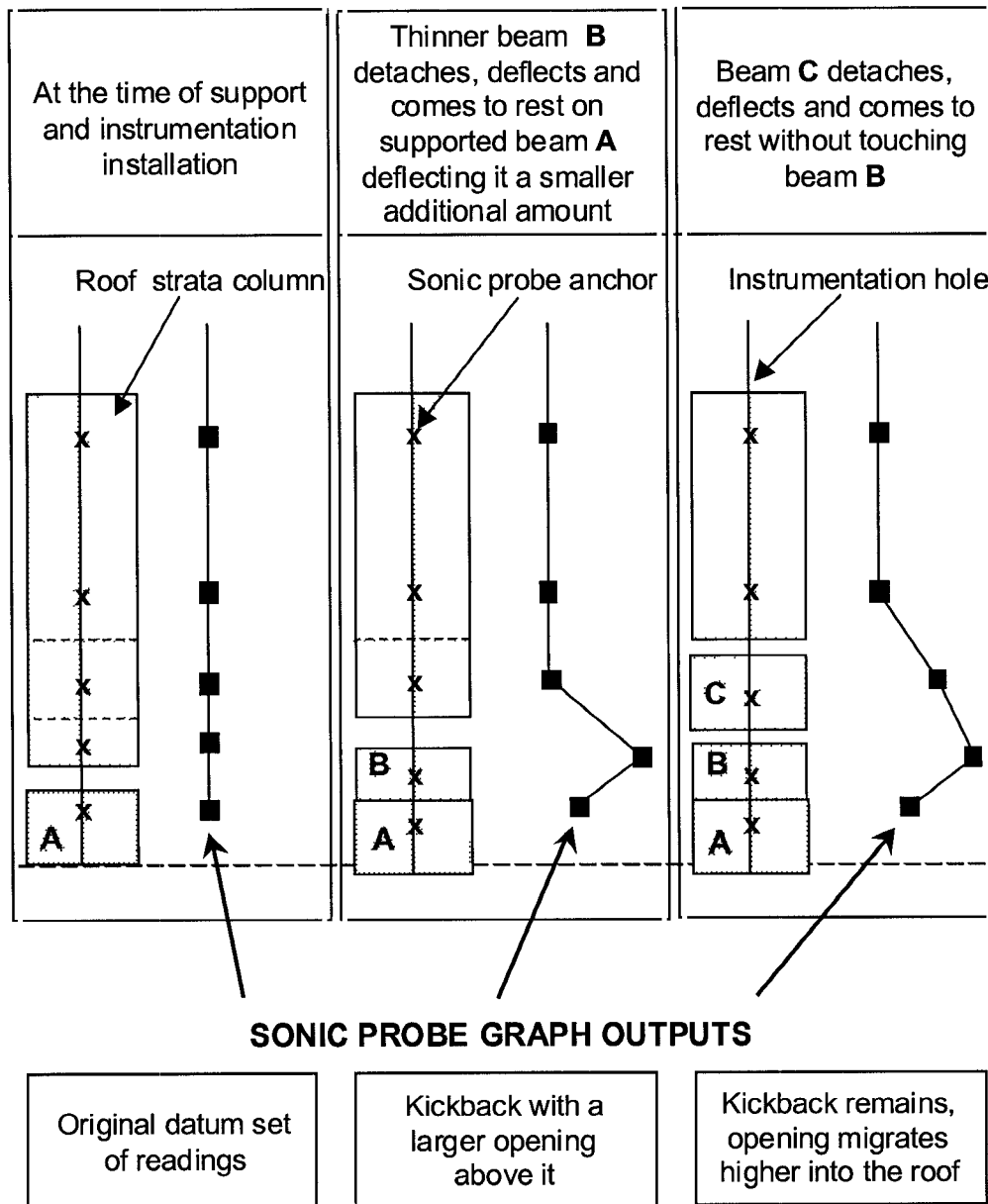

Figure 3.10. Beam deflection mechanism that could explain kickbacks close to the roof skin in sonic probe graphs

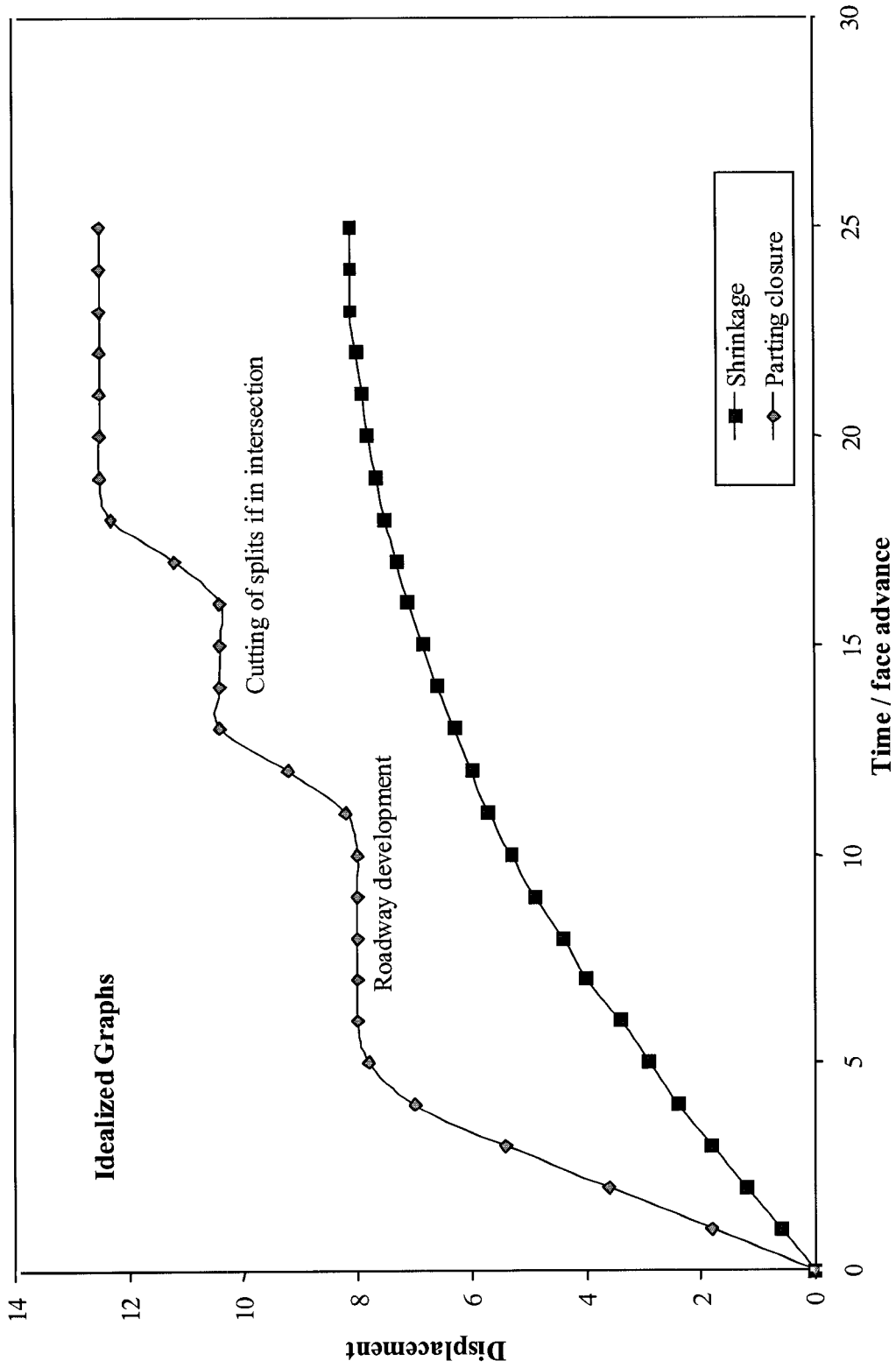

Figure 3.11. Comparison between shrinkage with time and parting closure with face advance

Four of the six sites, (Figures 3.4, 3.7, 3.8 and 3.9), two of which were intersections, were visited the day after installation, when the second sets of readings were taken. The respective faces had been advanced between 2.0 and 4.0 m. All five kickbacks had on average already developed to 88 per cent of their final values. The remaining two sites were only revisited after four days. Both the intersections, (Figures 3.4 and 3.7), indicated that the kickback values increased as the splits were developed. In comparison, the kickbacks in all four roadways were virtually 100 per cent developed when the second sets of readings were taken, between one and four days after installation with face advances of 2.0 m to 10 m.

The monitoring results at all six sites conform to the proposed parting closure graph profile in Figure 3.11. This again indicates that the pre-existing open parting beam deflection mechanism, as illustrated in Figure 3.10, is the most plausible explanation as to the roof behaviour at this particular colliery.

The question that arises, is, if there were pre-existing openings in the lower 2.5 m of the roof, why were they not detected by the petroscope inspections. Indications are that some openings may have been as wide as 5.0 mm.

As far as can be established there is no standard 50 mm drill bit compatible with the drill rods used in the collieries. To ream the hole out to 50 mm, a local engineering firm fabricated a drill bit by the addition of tungsten cutting blades. It was not possible to incorporate a water feed tube into the modification. It is for this reason that the final reaming, which enlarges the hole by a few millimetres and removes irregularities from the sides, was carried out dry. It is therefore a distinct possibility, particularly in a predominantly coal roof, that the moisture left in the hole by the original wet drilling could mix with the powdered coal duff and form a paste that is then smeared into any openings by the reaming process.

The flushing of horizontal holes drilled into pillars does not appear to present any problems as the monitoring of existing fractures in pillars has been successfully carried out by many people over the past two to three decades. The majority of the sidewall drilling was carried out dry, from the drilling of the initial hole right through to the final reaming. Drilling was predominantly carried out using hand held drilling machines with auger rods. Only once the reaming is complete is the hole flushed out with water. The usual process is to insert as large a hose as possible all the way to the back of the hole and to withdraw it slowly. This technique in a horizontal hole works satisfactorily.

The current flushing techniques used in the vertical holes, of inserting a hose to the top of the hole or spinning a smaller water flushing bit in the hole, appear to be inadequate. A method needs to be developed to enable any compacted residue from the softer strata types to be removed from pre-existing openings.

The comparative roof performance of all six sites is illustrated in Figure 3.12. From the results, the roadway in area one at site two appears to exhibit a different behaviour pattern to the other five sites with respect to the strata above the roof bolt horizon up to the 2.5 m elevation. Most of the activity in the roof strata at the other five sites is within the roof bolt horizon. The major positive opening displacements tend to be within the upper and lower limits of the 0.3 m shale band, i.e. between 0.5 and 1.3 m into the roof. This is the region where the bolts were fully resin grouted to consolidate the shale band. Kickback closure and opening displacements are also present closer to the roof skin in the coal below the shale band. Although displacements are indicated in general up to 0.5 m above the bolt horizon, the magnitudes are considerably less than those recorded within the bolt horizon. The upper displacement levels at both intersections are closer to the bolt horizon than some of the roadway sites. The additional 40 per cent increase in the span across the intersection diagonals appears to have had little or no effect on crack propagation between the top of the roof bolts and the 2.5 m elevation which was contrary to expectations. There are indications of some form of disturbance in the roof strata between the 2.5 and 4.0 m elevations at both intersections (and at the area one site two roadway). These results, presented in Figure 3.13, are however difficult to interpret.

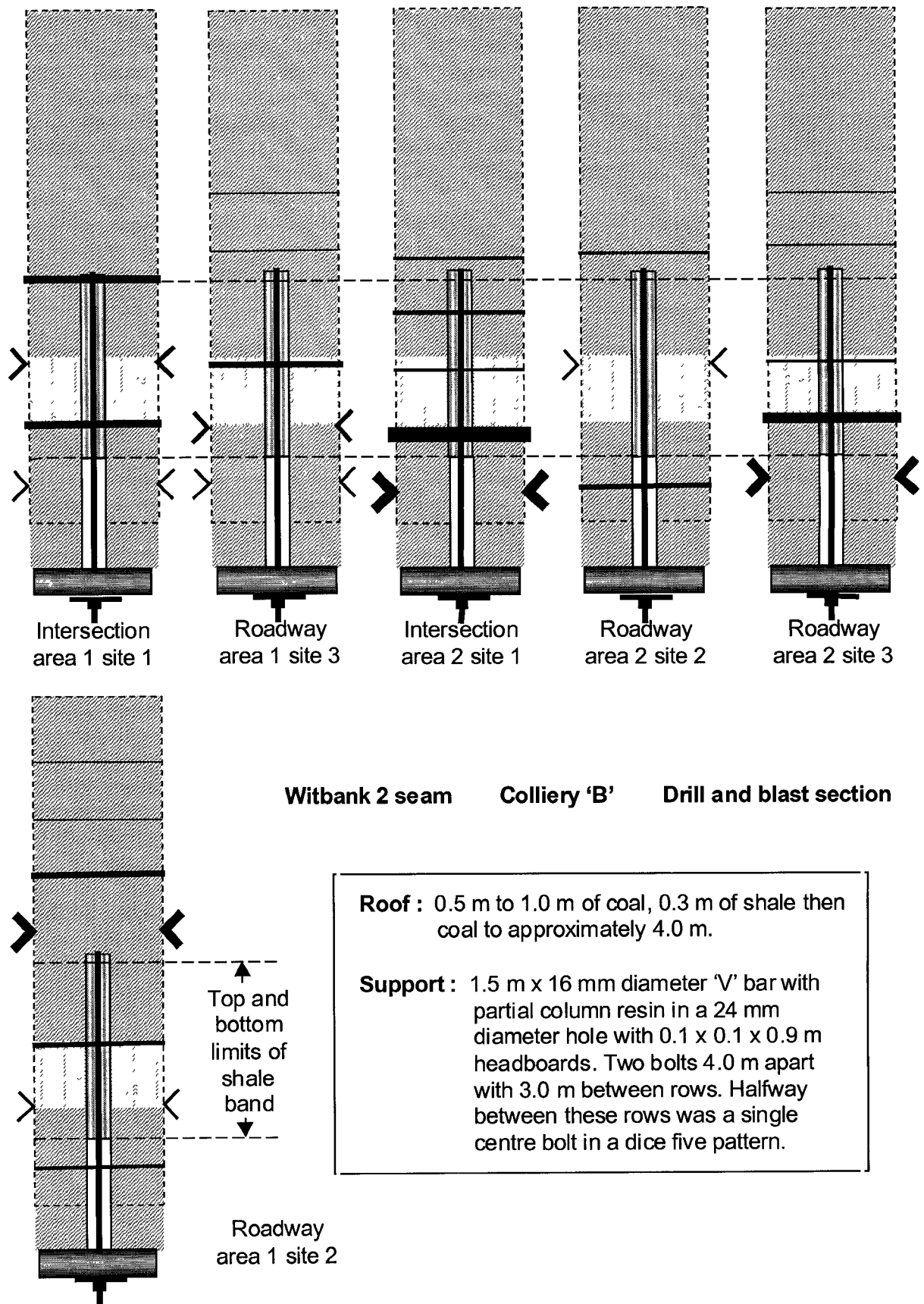

Figure 3.12 Colliery 'B' comparative roof behaviour

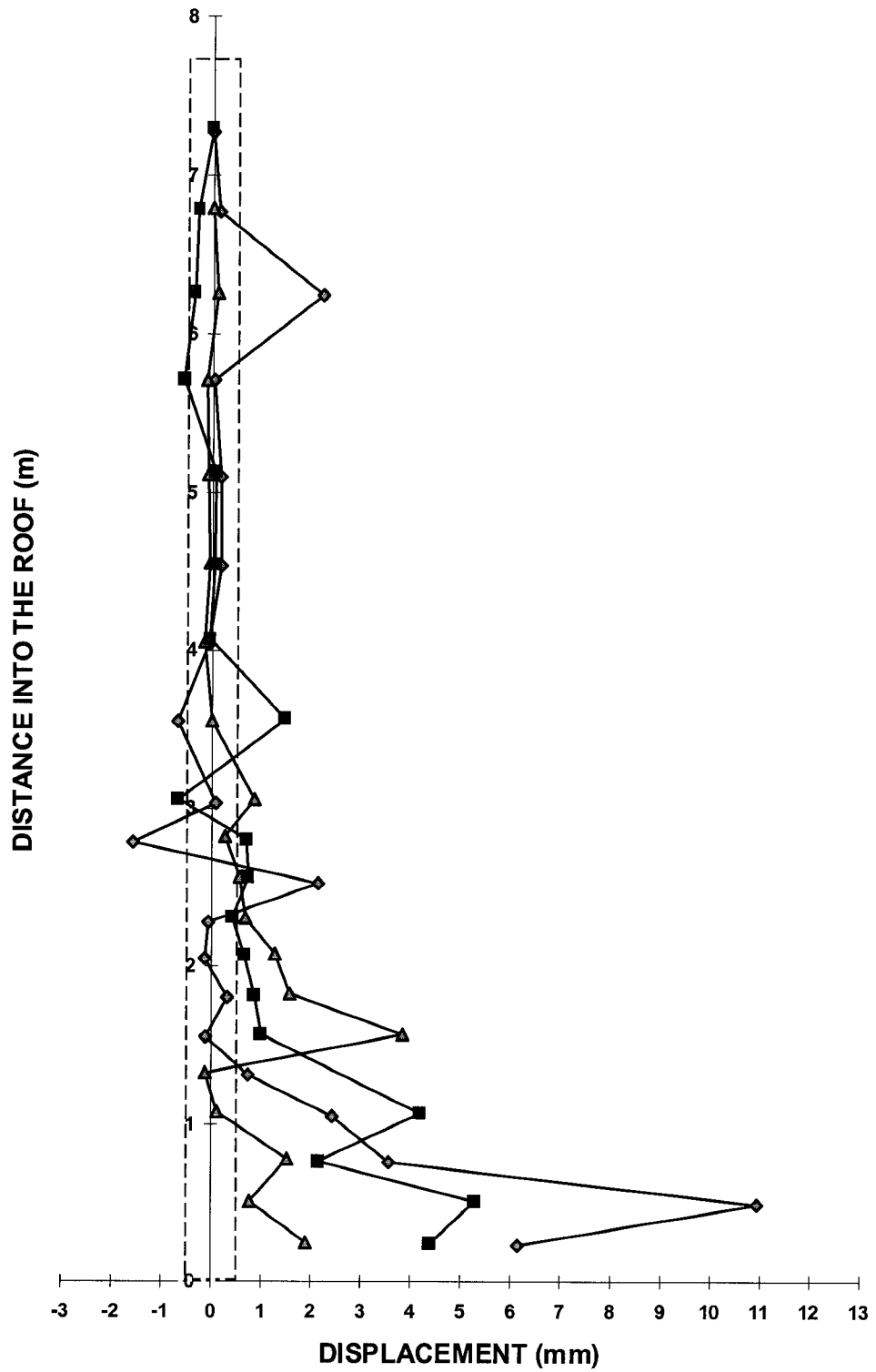

Figure 3.13. Disturbance in the roof between 2.5 m and 4.0 m elevations

The drill and blast mining method may have contributed to the open fractures in the roof as close as 0.5 m from the face. A requirement of the drill and blast mining method is that the support is advanced after each blast. Assuming a face advance of 2.0 m per blast, with the sonic probe hole at a maximum of 1.0 m from the face, the unsupported distance from the face should in this case not exceed 3.0 m. The ability for this particular roof to have openings occur within this 3.0 m limit is clearly illustrated in Figures 3.5, 3.8 and 3.9. When the second sets of readings were taken after 2.0 to 3.0 m face advance, in excess of 90 per cent of the recorded roof displacement had already taken place and relative stability was reached very soon thereafter.

As is to be expected the mining of the splits to form an intersection allowed the roof displacements to reach larger magnitudes than in the roadways. After completion of the mining cycle, the roadways and the intersections both stabilised very quickly. This is illustrated in Figure 3.14 where a comparison between the roof skin displacements, derived from the backup levelling results, at the intersection at area one site one and the roadway at area one site three are presented. The displacements of the bottom anchor near the collar of the hole in the intersection at area one site one is presented in Figure 3.15. Figure 3.16 shows the velocity profile of the same anchor. Stability was reached shortly after the splits were holed through at the 25 m face advance. The final reading was taken approximately 50 days after the initial indication that the roof had stabilised.

The overall total relaxation at the roof skin in area two was about 50 per cent higher than in area one. From visual observation both roof conditions appeared to be similar with falls of ground being limited to isolated cases between the headboards. This type of roof fall usually involves relatively small thin pieces of coal. Contributing factors appeared to include the unevenness associated with a blasted roof, the affect of additional blasting vibrations and the fact that repeated checking of the roof for loose hanging is that much more difficult in a 3.0 m mining height.

3.5.1 Site performance summary colliery 'B'

Coalfield	: Witbank	Seam	: 2 Seam
Sites	: Six	Positions	: Two intersections four roadways
Road widths	: 6.0 m	Pillar widths	: 9.0 m Mining height : 3.0 m
Depth	: 40 m	Mining method	: Drill and blast

Roof strata : 0.5 m to 1.0 m coal, 0.3 m shale then coal to approximately 4.0 m

Support : 1.5 m x 16 mm diameter 'V' bar with partial column resin in a 24 mm diameter hole with 0.1 x 0.1 x 0.9 m headboards. Two bolts 4.0 m apart with 3.0 m between rows. Half way between these rows is a single centre bolt in a dice five pattern.

Performance : Indications are that displacement occurred in the roof strata when the face was advanced with the blast, increasing the unsupported roof span up to 3.0 m. This resulted in open parting planes and fractures being present as close as 0.5 m from the face prior to the installation of the support and instrumentation. Further displacements, mainly within the roof bolt horizon, occurred quickly, within one or two blasts as the face advanced. The overall stability of the roof occurred quickly in the bords and intersections once the splits had been mined.

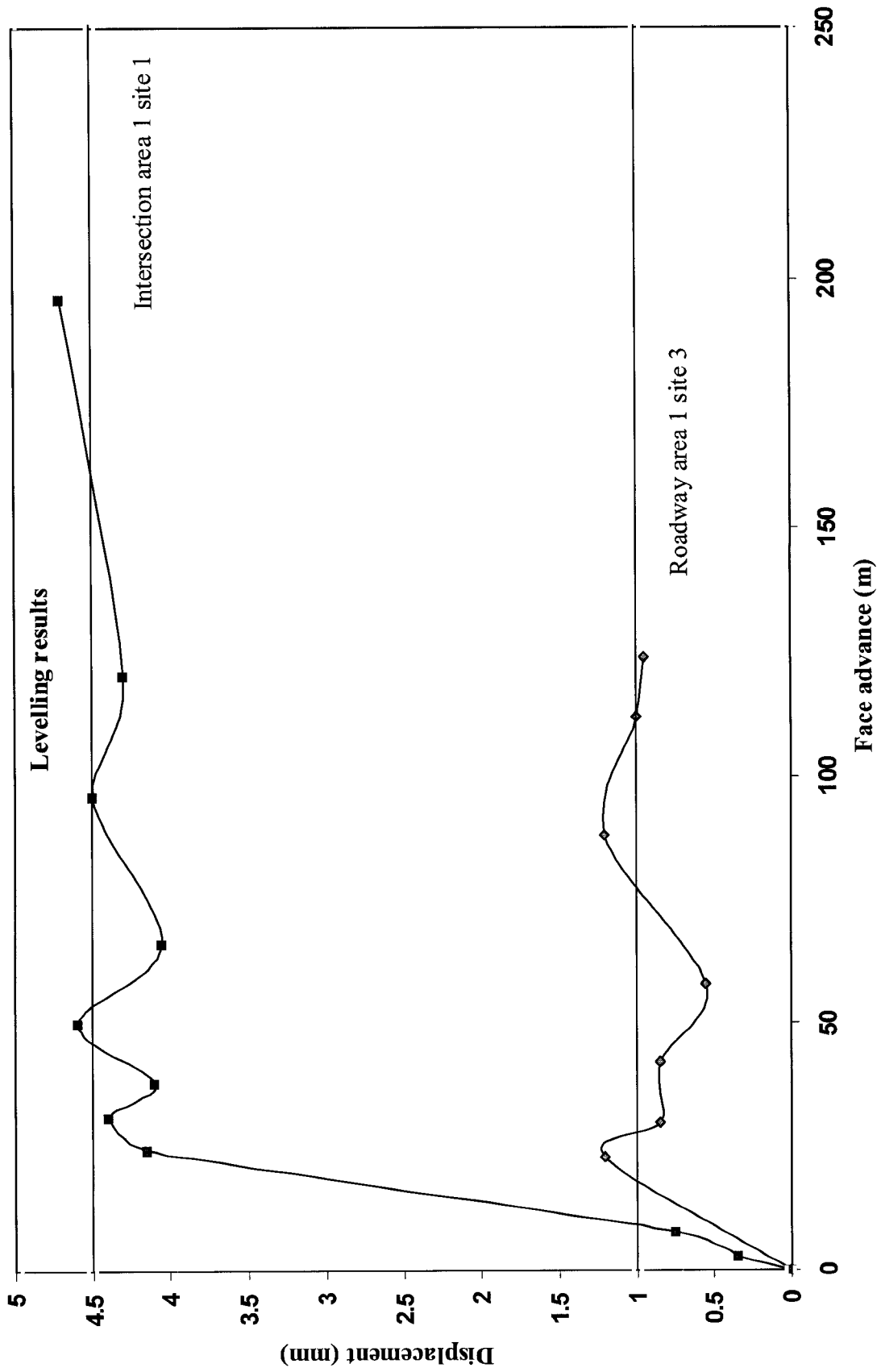

Figure 3.14. Colliery 'B' comparison between roadway and intersection roof skin displacement

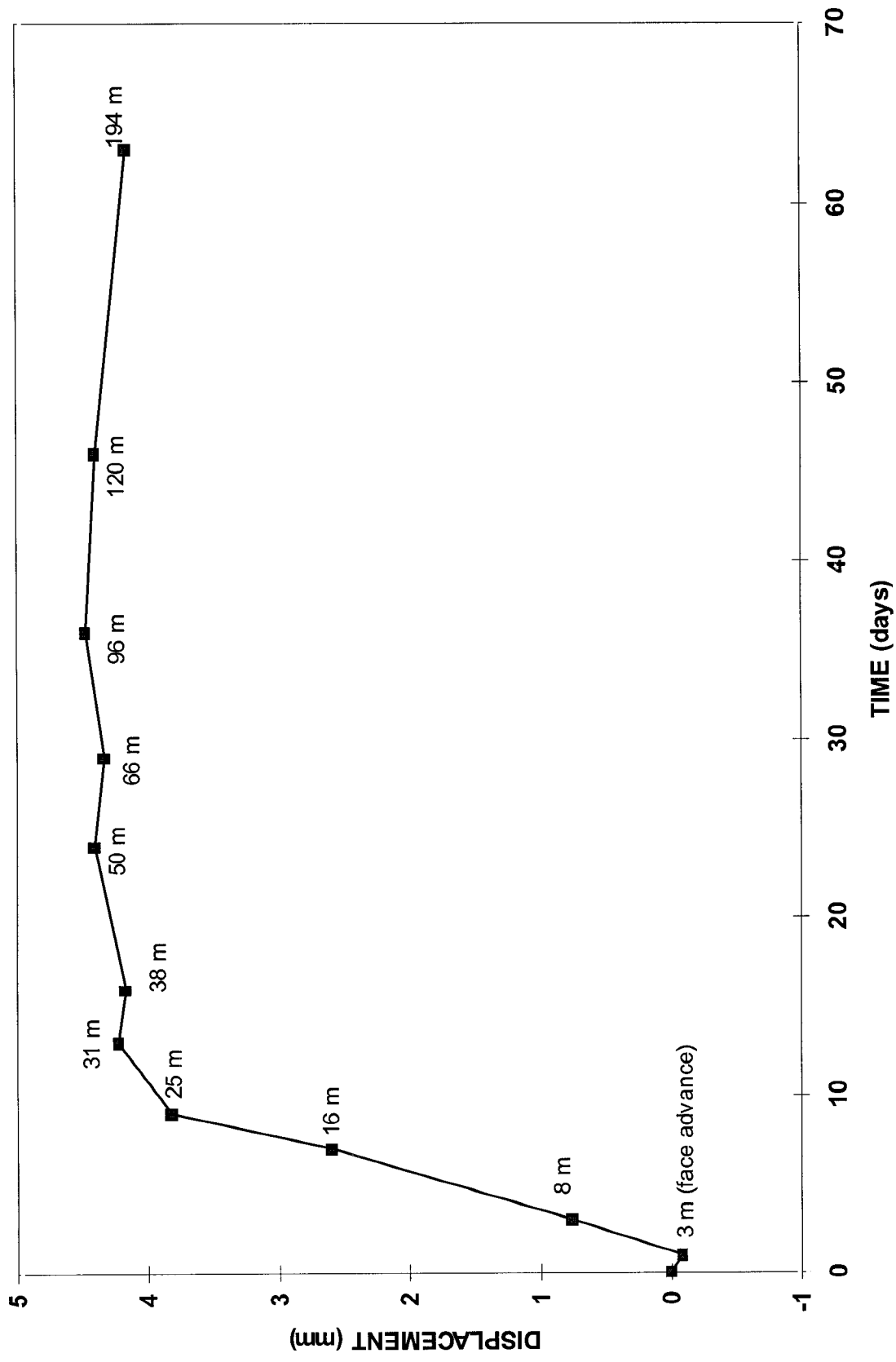

Figure 3.15. Colliery 'B' area 1 site 1 (intersection) collar anchor displacement

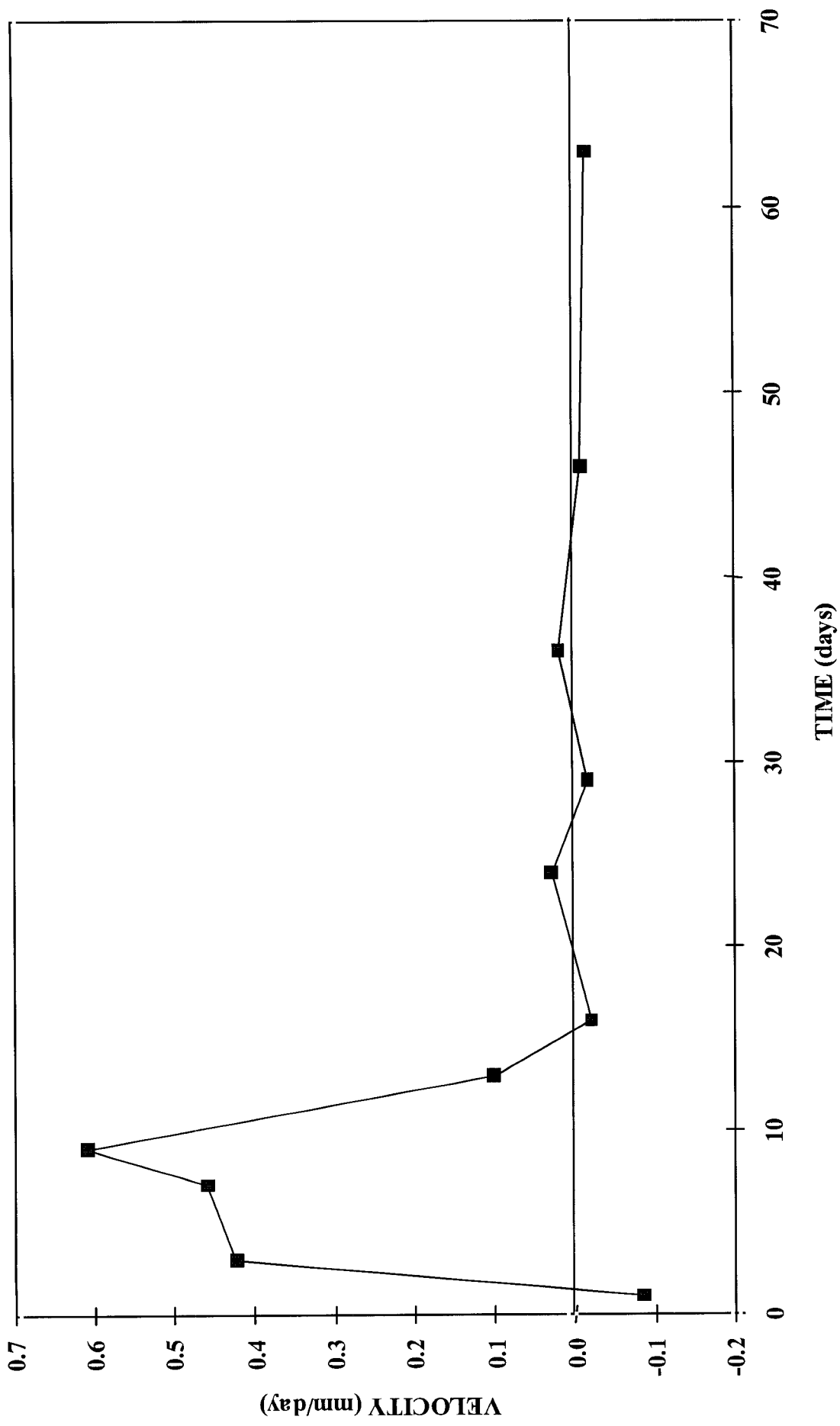

Figure 3.16. Colliery 'B' area 1 site 1 collar anchor velocity

3.6 Colliery 'C'

At colliery 'C' theft of equipment resulted in one site being abandoned. Back up levelling results were only viable at two of the four sites as a result of blast damage to levelling installations.

Sites one and two, an intersection and adjacent roadway respectively, were situated approximately 25 m away from sites three and four, another intersection and roadway. The immediate roof consisted of a coal layer approximately 0.3 m thick with shale above it. The standard support was 1.8 m x 16 mm mechanical end anchored bolts, three in a row with the rows 2.0 m apart. The boltholes were drilled with electric hand held drills. The bolts were installed and tensioned by using the electric drills.

The results from all four sites suggest that there were pre-existing open fractures or bedding planes at a variety of elevations within the initial 2.5 m of roof strata, as close as 0.5 m from the face. At a site in one intersection, Figure 3.17, there is evidence of an open parting in the vicinity of the coal/shale interface. Openings at this elevation were not detected at any of the other three sites.

The other kickback at site one occurred close to the top of the bolt horizon at around the 1.8 m elevation. This phenomenon is also evident at site two, Figure 3.18, around the 2.0 m elevation. In the roadway at site four, Figure 3.20, which experienced the smallest displacements of all four sites, there is an indication of a similar trend around the 2.0 m elevation. At site four, although the kickback value falls just below the 0.5 mm criterion, it has been recorded on the strata column. This is because it appears to be part of a trend, which is present in three of the sites and suggests the presence of a layer with little or no cohesion as opposed to errors in the readings.

In general the total relaxation, which occurred within or close to the roof bolt horizon, was very small. The largest displacements were recorded at the intersection in site three, Figure 3.19, where the total relaxation was 3.5 mm. Also evident at site three was a 1.0 mm kickback at around the 1.0 m elevation. The final levelling result value was 30 per cent larger than indicated by the lowest sonic probe anchor close to the collar of the hole. This indicates the presence of an additional displacement of approximately 1.5 mm between 0.1 and 0.2 m in from the roof skin. These were the elevations of the levelling skin anchor and the bottom sonic probe anchor, respectively. At site two the levelling results and the lowest sonic probe anchor close to the collar of the hole gave near identical values.

As was the case in colliery 'B' roof displacement in the form of open fractures or bedding planes appeared to occur very close to the face (within 0.5 m) as the blasting extended the unsupported roof span up to a maximum of approximately 3.0 m. Most of the subsequent displacements that occurred after the installation of the support and instrumentation were close to or within the roof bolt horizon, as illustrated in Figure 3.21. In general, the roof displacements appeared to have stabilised when the face had advanced to the bord with i.e. 6.0 m.

**Section of strata column
under investigation**

Legend

Day 1 installation at 0.9 m

- A = day 2 (face advance 3 m)
- B = day 5 (face advance 5 m)
(Splits mined)
- C = day 15 (face advance 25 m)

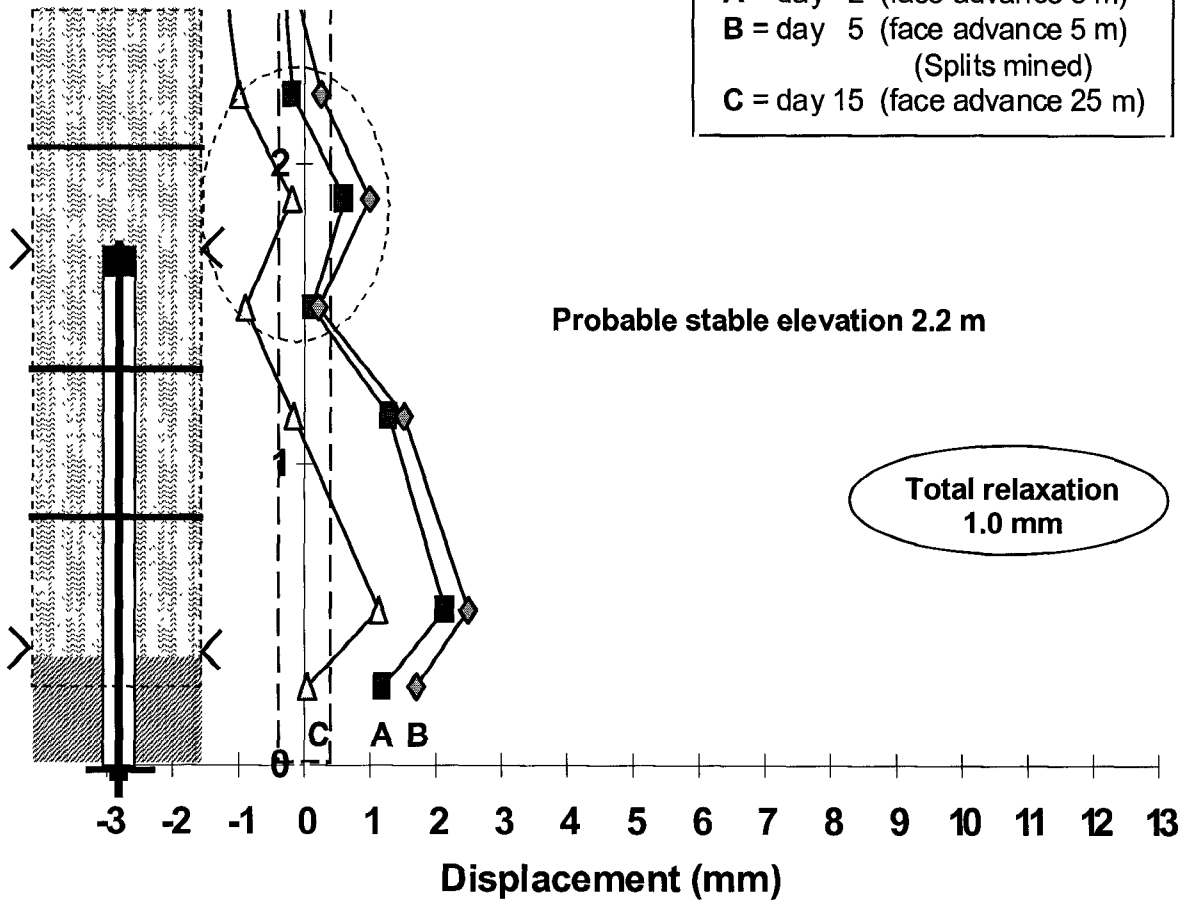

Notes

Coalfield : Witbank **Seam** 2 seam **Position** Intersection

Roof : Approximately 0.3 m of coal with shale above it.

Support : 1.8 m x 16 mm mechanical end anchored bolts 3 in a row with rows 2.0 m apart. Bolt holes drilled with electric hand held drills.

Layout : **Depth** 50 to 60 m **Roadway** 6.0 m **Pillar** 9.0 m

Mining : Conventional drill and blast **Mining height** 2.2 m

Displacements appeared to have occurred up to 0.4 m above the bolt horizon. Kickbacks are evident close to the coal roof skin / shale contact and at the top of the bolt horizon.

Figure 3.17. Colliery 'C' site 1 (intersection)

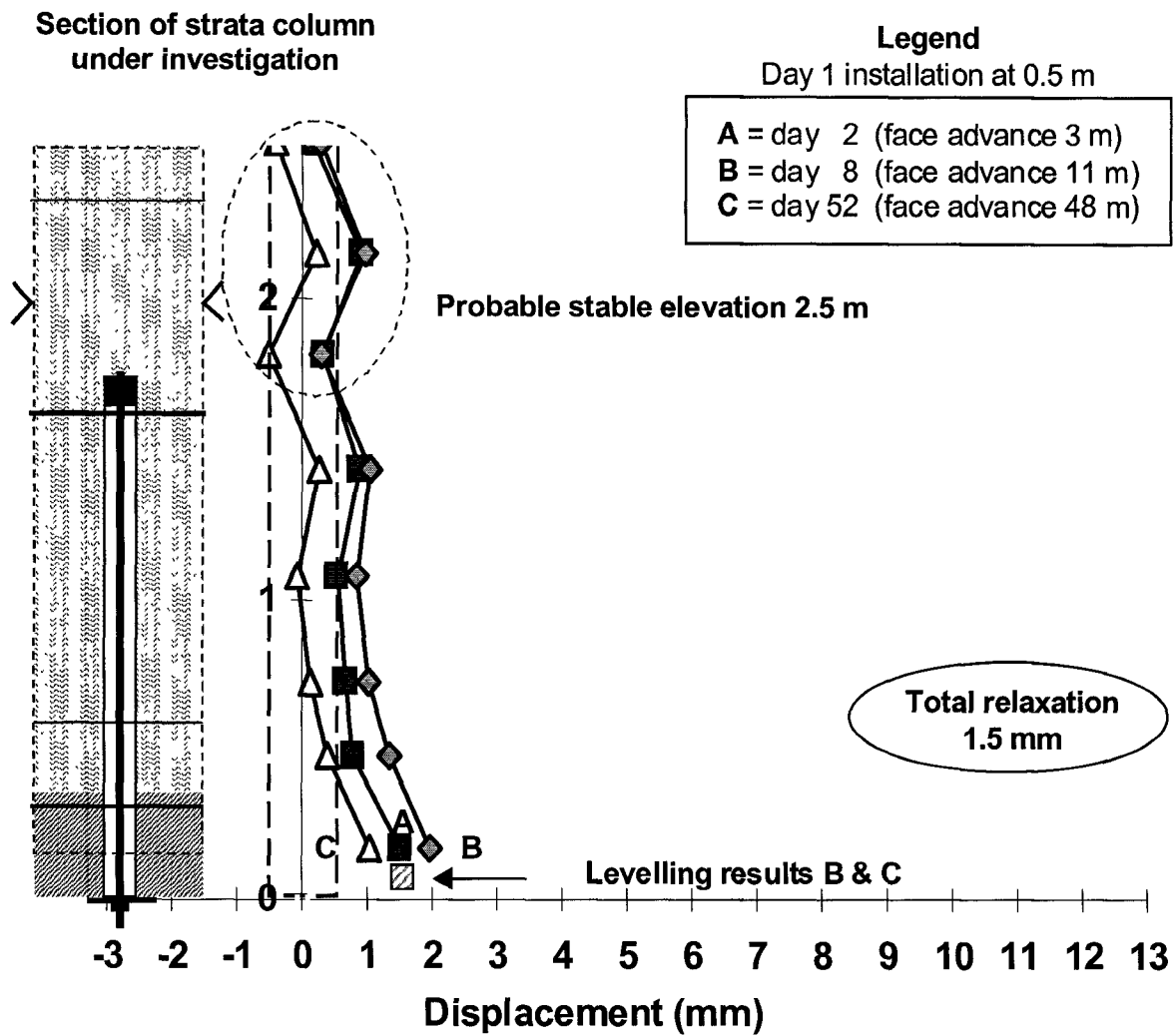

Notes

Coalfield : Witbank **Seam** 2 seam **Position** Roadway

Roof : Approximately 0.3 m of coal with shale above it.

Support : 1.8 m x 16 mm mechanical end anchored bolts 3 in a row with rows 2.0 m apart. Bolt holes drilled with electric hand held drills.

Layout : **Depth** 50 to 60 m **Roadway** 6.0 m **Pillar** 9.0 m

Mining : Conventional drill and blast **Mining height** 2.2 m

Displacements appear to have occurred as high as 0.7 m above the bolt horizon with a single kickback close to the 2.0 m elevation.

Figure 3.18. Colliery 'C' site 2 (roadway)

**Section of strata column
under investigation**

Legend

Day 1 installation at 0.6 m

- A = day 2 (face advance 3 m)
- B = day 9 (face advance 7 m)
(splits mined)
- C = day 43 (face advance 39 m)

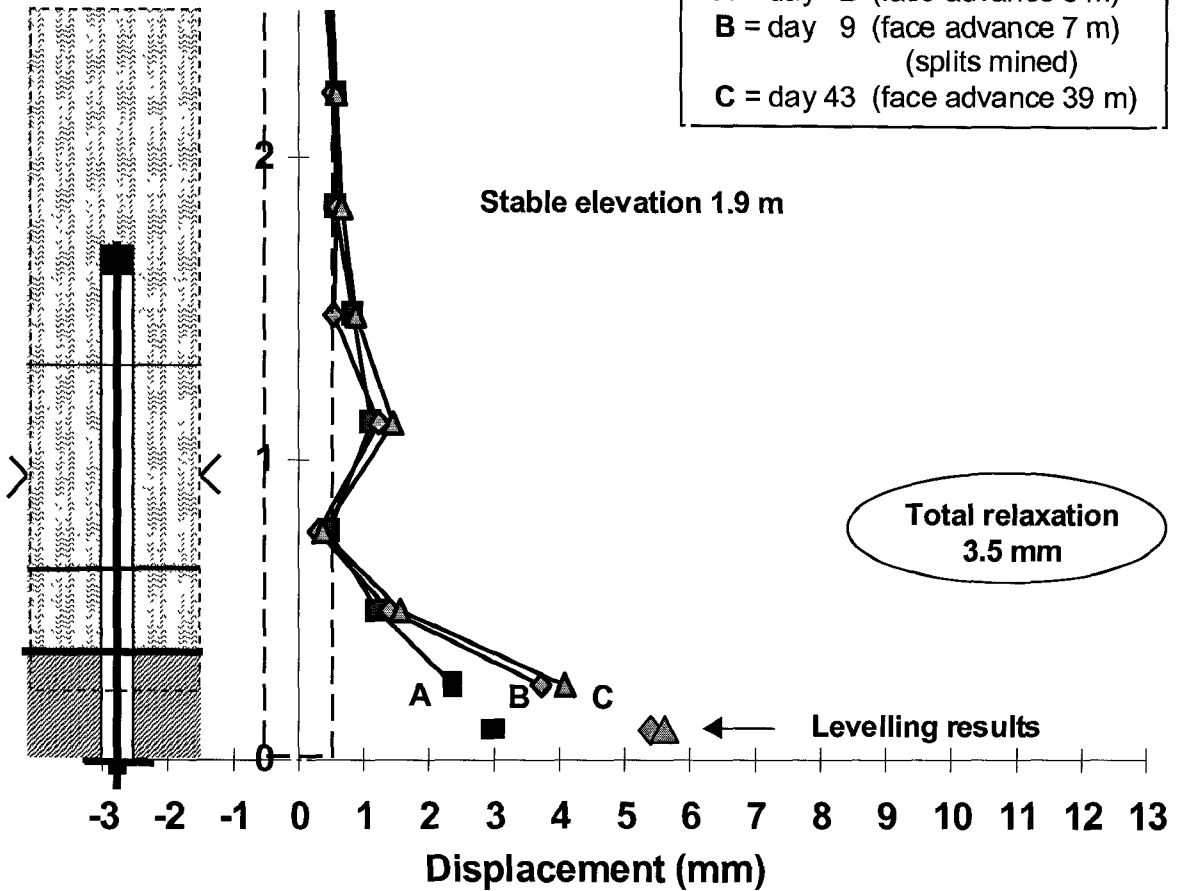

Notes

Coalfield :Witbank **Seam** 2 seam **Position** Intersection

Roof : Approximately 0.3 m of coal with shale above it.

Support : 1.8 m x 16 mm mechanical end anchored bolts 3 in a row with rows 2.0 m apart. Bolt holes drilled with electric hand held drills.

Layout : **Depth** 50 to 60 m **Roadway** 6.0 m **Pillar** 9.0 m

Mining : Conventional drill and blast **Mining height** 2.2 m

All the displacements appear to have taken place within or close to the bolt horizon. There was a kickback at approximately the 1.0 m elevation. Positive opening displacements of about 4.0 mm in total occurred within the initial 0.8 m of roof strata.

Figure 3.19. Colliery 'C' site 3 (intersection)

Section of strata column under investigation

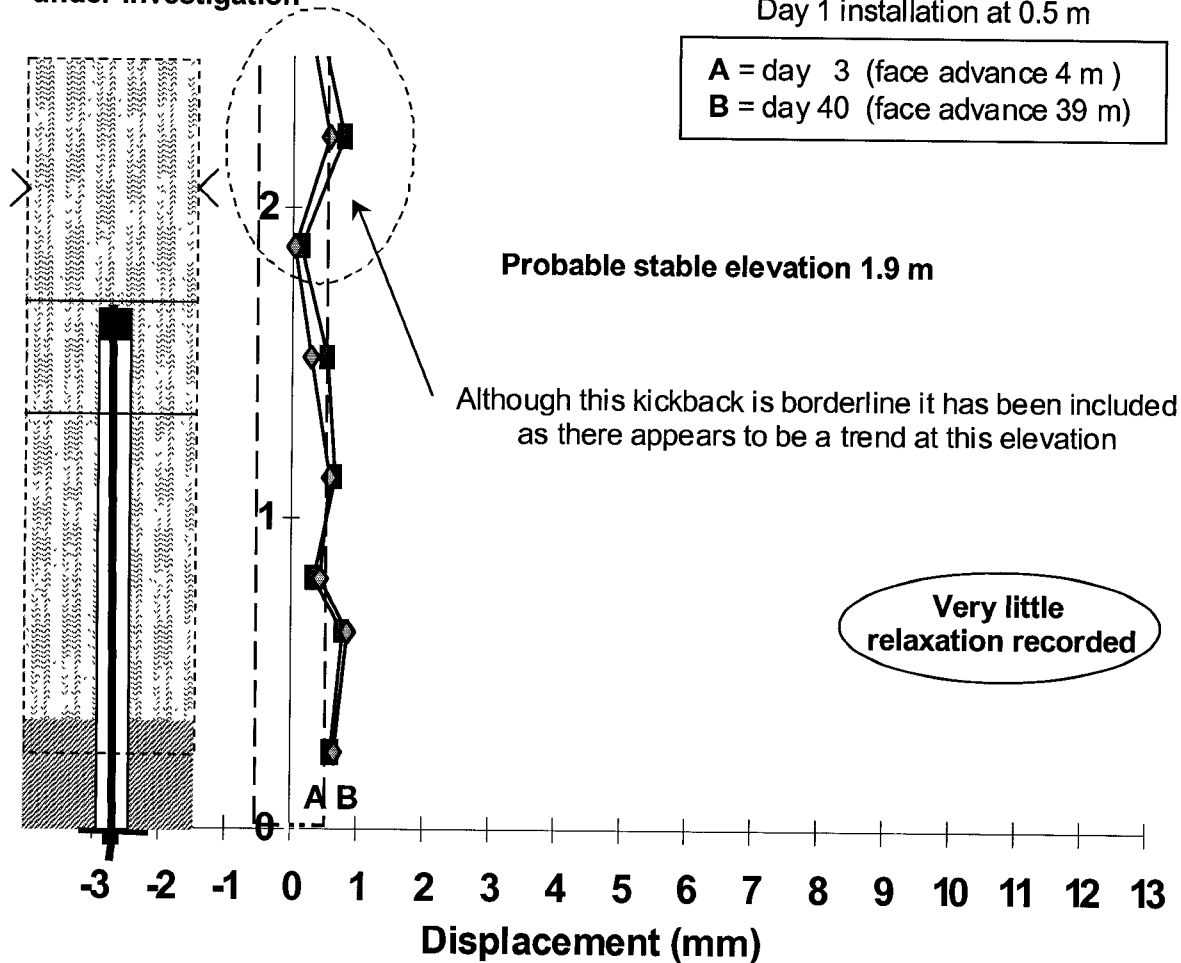

Notes

Coalfield : Witbank **Seam :** 2 seam **Position :** Roadway

Roof : Approximately 0.3 m of coal with shale above it.

Support : 1.8 m x 16 mm mechanical end anchored bolts 3 in a row with rows 2.0 m apart. Bolt holes drilled with electric hand held drills.

Layout : **Depth** 50 to 60 m **Roadway** 6.0 m **Pillar** 9.0 m

Mining : Conventional drill and blast **Mining height** 2.2 m

The overall displacements recorded, although very small, extended to just above the bolt horizon. There is also a possible kickback around the 2.0 m elevation which, although slightly less than 0.5 mm, has been included as it appears to be part of a trend in this particular roof type.

Figure 3.20. Colliery 'C' site 4 (roadway)

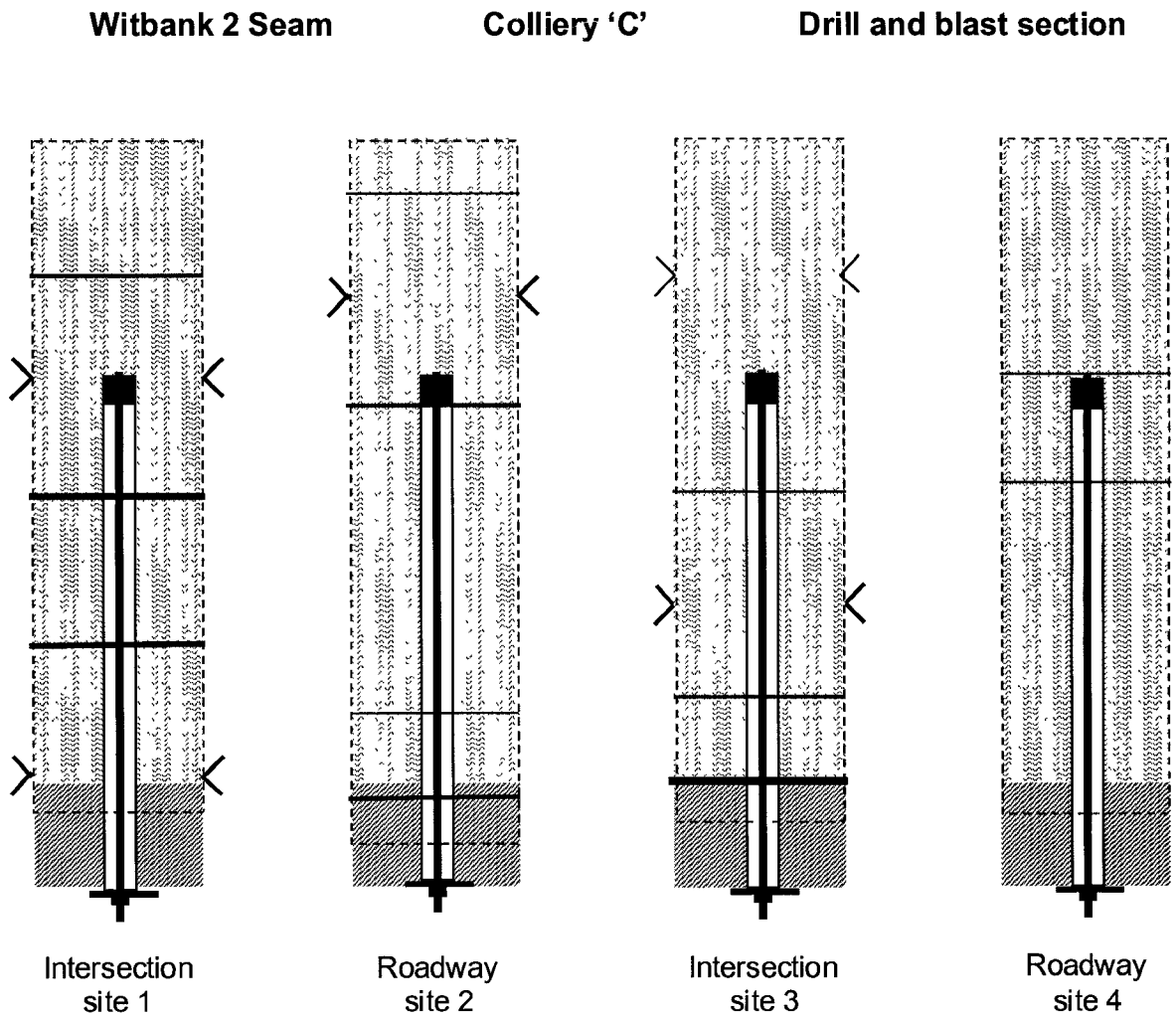

Roof : Approximately 0.3 m of coal with shale above it.

Support : 1.8 m x 16 mm mechanical end anchored bolts three in a row with rows 2.0 m apart. Bolt holes drilled with electric hand held face drills. Bolts tensioned using the electric drill.

Figure 3.21. Colliery 'C' comparative roof behaviour

3.6.1 Site performance summary colliery 'C'

Coalfield	: Witbank	Seam	: 2 Seam
Sites	: Four	Positions	: Two intersections two roadways
Road widths	: 6.0 m	Pillar widths	: 9.0 m Mining height : 2.2 m
Depth	: 50 to 60 m	Mining method	: Conventional drill and blast

Roof strata : Approximately 0.3 m of coal with shale above it.

Support : 1.8 m x 16 mm diameter mechanical end anchored bolts.
Three bolts per row with rows 2.0 m apart.

Performance : Indications are that displacement occurred in the roof strata when the face was advanced with the blast, increasing the unsupported roof span by up to 3.0 m. This resulted in open parting planes and fractures being present as close as 0.5 m from the face prior to the installation of the support and instrumentation.

Although there is evidence of isolated cases of openings at approximately 0.3 m and 1.0 m into the roof, three of the four sites indicate the possible presence of an opening around the 2.0 m elevation just above the bolt horizon. Further small displacements, mainly within the roof bolt horizon, occurred quickly, within one or two blasts as the face advanced. Stability of the roof also occurred quickly, even in the intersections once the splits had been mined.

3.7 Colliery 'D'

Over a 20 month period investigations were carried out at three different locations at colliery 'D'. A total of 12 sites were monitored covering four support combinations and two mining methods. The roof consisted of laminated sandstone and shale highly variable bedding thicknesses that changed every few metres. The support pattern of four bolts per row with rows 1.5 m apart remained the same at all the sites. Backup levelling was carried out at eight of the sites.

In the first area, two intersections and two roadways were monitored. The support method used was 1.5 m long 15 mm spiral bars. These were installed in 22 mm diameter holes using three 19 x 380 mm resin cartridges giving a full column resin bond. The mining method used was conventional drill and blast. As is usual practice, each blast advanced the full face width of 6.0 m by approximately 2.0 m. This resulted in unsupported maximum exposed roof distances, from the last row of support up to the face, of approximately 3.5 m. The monitoring hole was always within 1.0 m of the nearest roof bolt.

The individual monitoring results are presented in Figures 3.22, 3.23, 3.24 and 3.25. The results from sites one, two and three include kickbacks that indicate the presence of pre-existing open fractures or bedding planes within 0.5 m of the face. The kickbacks were predominantly within the initial 0.4 m of the roof. At site one (Figure 3.22) there was also a kickback close to the top of the bolt horizon. The levelling results at all four sites were similar to, but generally had slightly larger values than those indicated by the lowest sonic probe anchor.

The intersection at site one (Figure 3.22) was the only site that appeared to have experienced displacements above the bolt horizon. It is difficult to determine if there was any displacement in the 0.5 m above the bolt horizon in the other intersection at site three (Figure 3.24) due to what appear to be anomalous readings. The average total relaxation experienced at the intersections was 4.5 mm whereas that in the roadways was less than 1.0 mm.

Section of strata column under investigation

Legend

Day 1 installation at 0.5 m

- A = day 7 (face advance 7 m)
- B = day 16 (face advance 7 m)
(splits mined)
- C = day 37 (face advance 22 m)
- D = day 107 (mining continues)

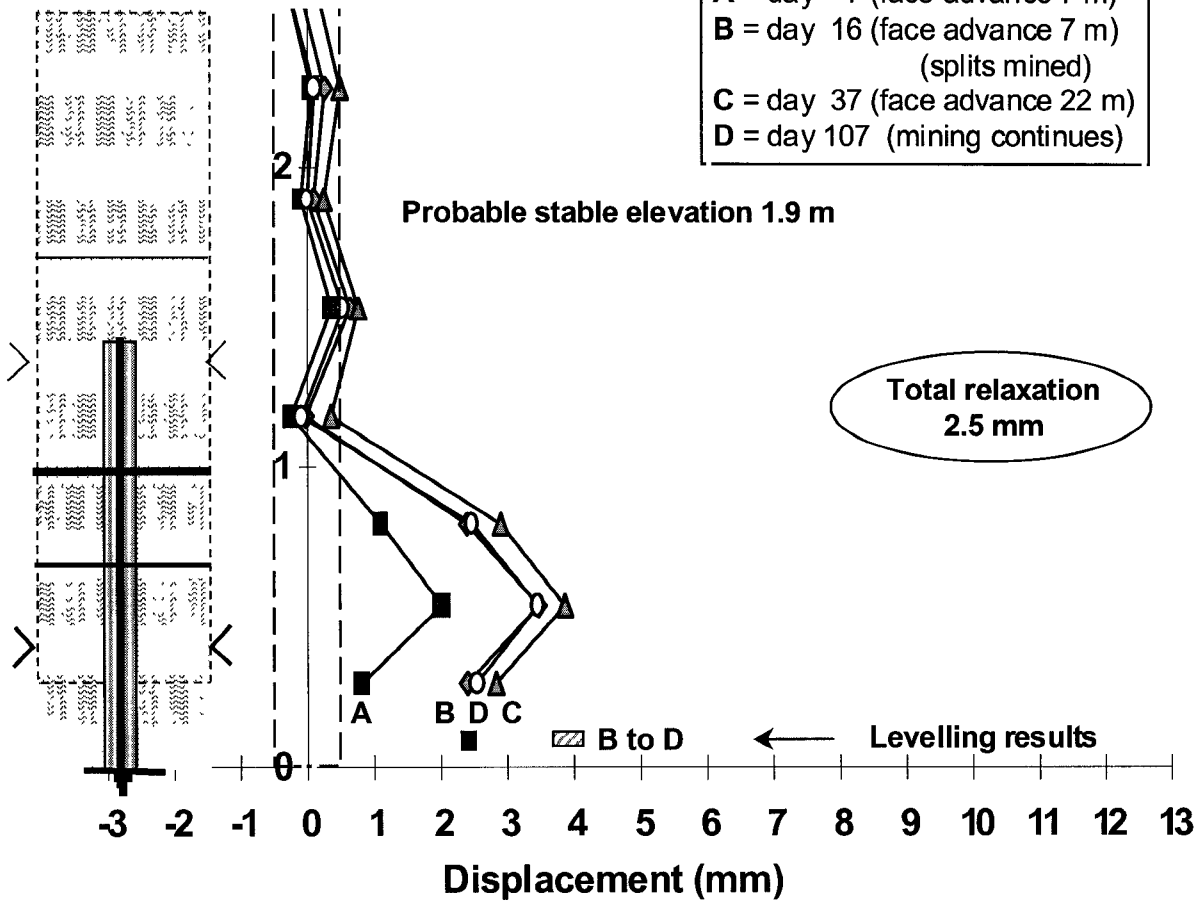

Notes

Coalfield : Witbank **Seam :** 2 seam **Position :** Intersection

Roof : Laminated sandstone & shale with highly variable bedding thicknesses

Support : 1.5 m x 15 mm spiral bars with full column resin in 22 mm diameter holes. Four bolts per row with rows 1.5 m apart.

Layout : Depth 55 to 60 m **Roadway :** 6.0 m **Pillar :** 6.0 m

Mining : Conventional drill and blast **Mining height :** 2.1 m

Figure 3.22. Colliery 'D' area 1 site 1 (intersection)

**Section of strata column
under investigation**

Legend

Day 1 installation at 0.5 m

- A = day 4 (no face advance)
- B = day 6 (face advance 7 m)
- C = day 20 (face advance 23 m)
- D = day 97 (face advance 51 m)

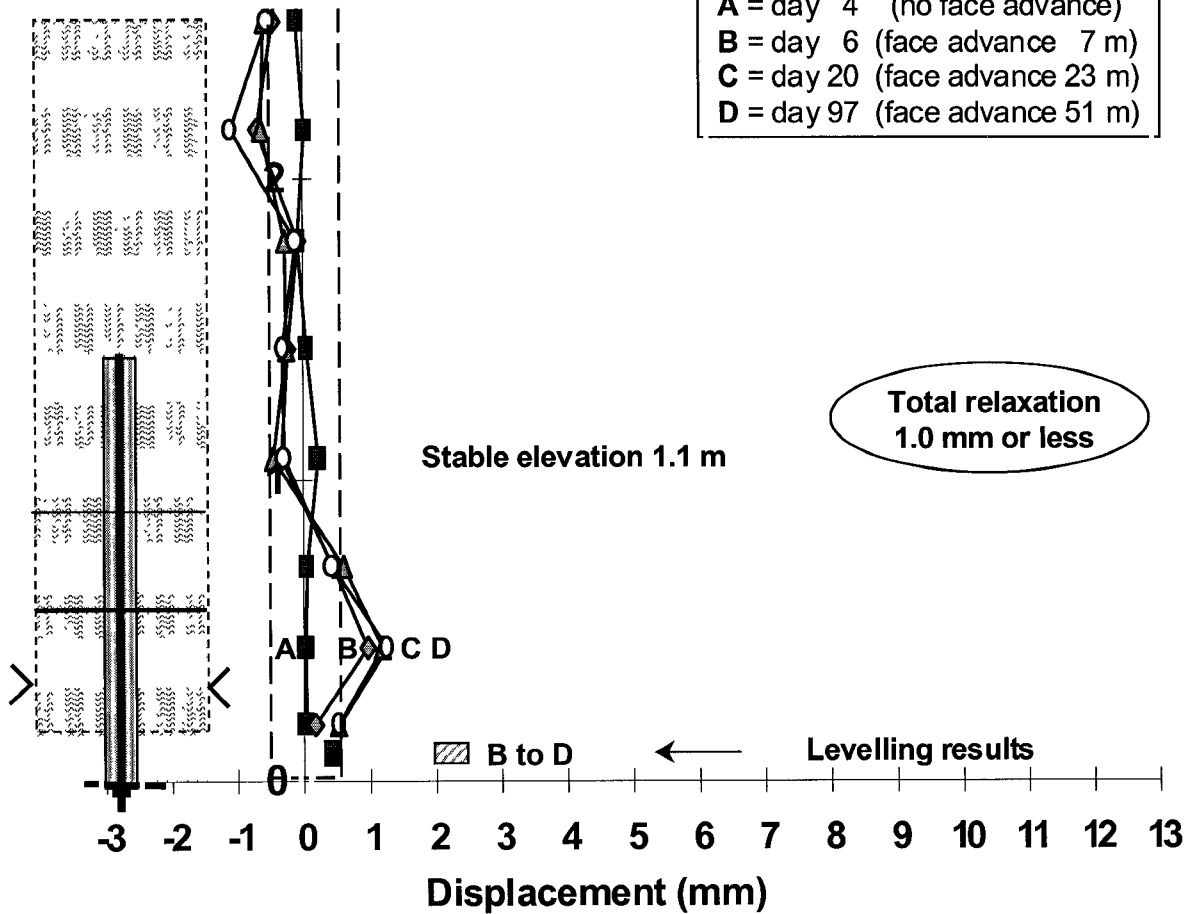

Notes

Coalfield :Witbank **Seam** 2 seam **Position** Roadway

Roof : Laminated sandstone & shale with highly variable bedding thicknesses

Support : 1.5 m x 15 mm spiral bars with full column resin in 22 mm diameter holes. Four bolts per row with rows 1.5 m apart.

Layout : Depth 55 to 60 m **Roadway** 6.0 m **Pillar** 6.0 m

Mining : Conventional drill and blast **Mining height** 2.1 m

Figure 3.23. Colliery 'D' area 1 site 2 (roadway)

**Section of strata column
under investigation**

Legend

Day 1 installation at 0.5 m

- A = day 6 (face advance 6 m)
- B = day 13 (mined 6 m right split)
- C = day 14 (face advanced 10 m)
(both splits holed through)
- D = day 83 (mining completed)

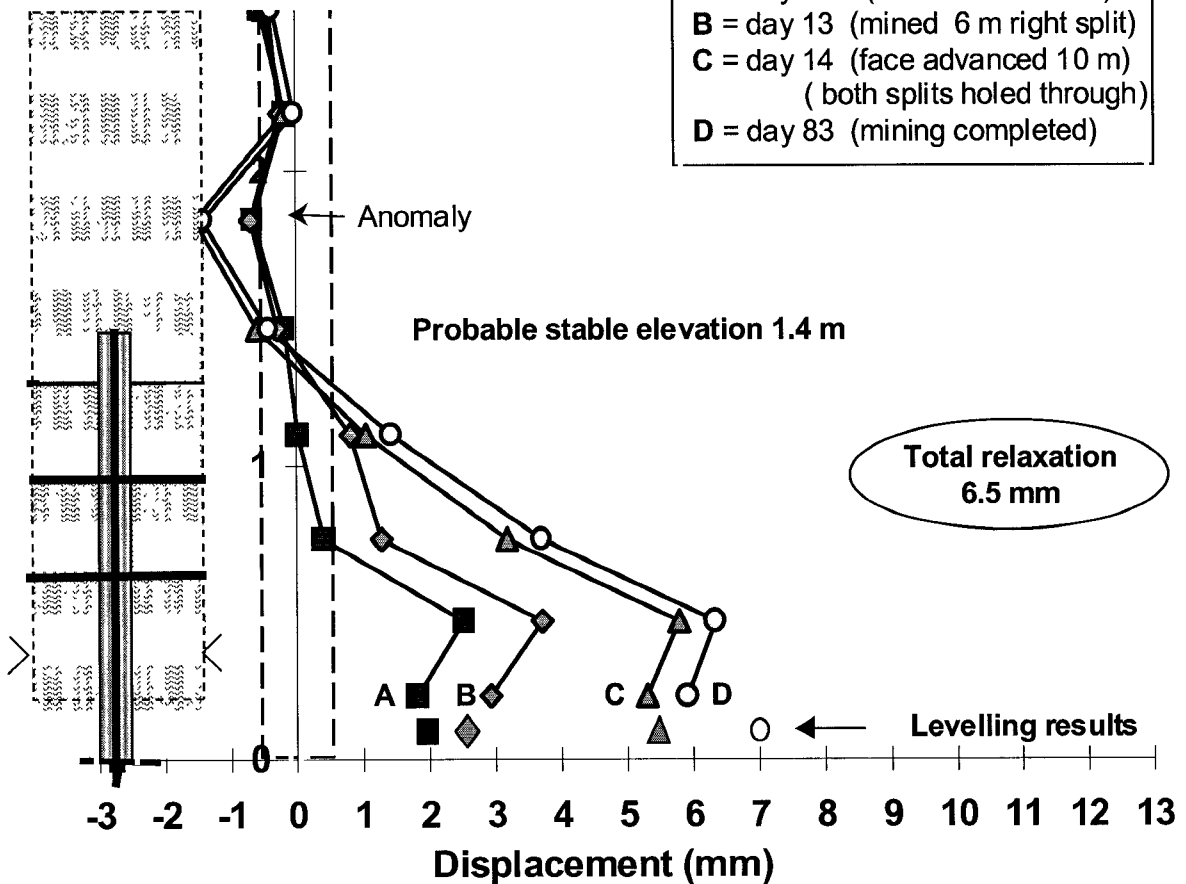

Notes

Coalfield : Witbank **Seam :** 2 seam **Position :** Intersection

Roof : Laminated sandstone & shale with highly variable bedding thicknesses

Support : 1.5 m x 15 mm spiral bars with full column resin in 22 mm diameter holes. Four bolts per row with rows 1.5 m apart.

Layout : Depth 55 to 60 m **Roadway :** 6.0 m **Pillar :** 6.0 m

Mining : Conventional drill and blast **Mining height :** 2.1 m

Figure 3.24. Colliery 'D' area 1 site 3 (intersection)

**Section of strata column
under investigation**

Legend

Day 1 installation at 0.5 m

- A** = day 2 (face advance 4 m)
- B** = day 6 (face advance 10 m)
- C** = day 9 (face advance 28 m)
- D** = day 69 (mining complete)

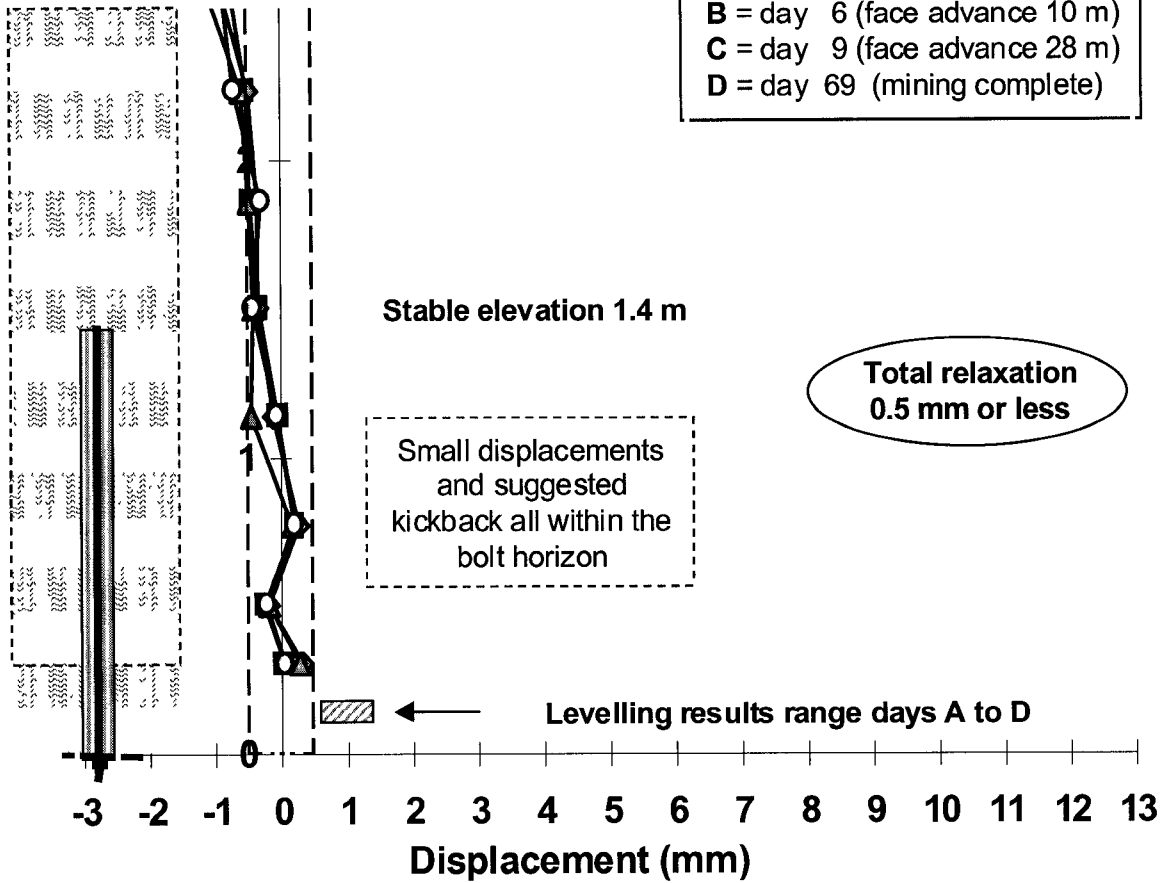

Notes

Coalfield : Witbank **Seam :** 2 seam **Position :** Roadway

Roof : Laminated sandstone & shale with highly variable bedding thicknesses

Support : 1.5 m x 15 mm spiral bars with full column resin in 22 mm diameter holes. Four bolts per row with rows 1.5 m apart.

Layout : Depth 55 to 60 m **Roadway :** 6.0 m **Pillar :** 6.0 m

Mining : Conventional drill and blast **Mining height :** 2.1 m

Figure 3.25. Colliery 'D' area 1 site 4 (roadway)

In the roadway at site four there were indications of very small displacements and a possible small kickback. These were however all less than the accepted accuracy band and have therefore not been transferred onto the strata column. The smallest face advance that took place before the second set of readings was taken was 4.0 m at site four. The displacements that were recorded had virtually all taken place by the time of the second visit.

All four sites have been grouped together in Figure 3.26. The magnitude of opening that occurred and the elevations that they were confined to can be clearly seen. This particular support system appears to have worked well in the prevailing roof strata conditions.

The levelling results of the roof skin behaviour relative to the 1.8 m datum, for all four sites, have been plotted and are presented in Figure 3.27. To compare roadway roof behaviour it is easy and probably more accurate to use face advance as opposed to time as one of the axes. The complex nature of "face advance" during the development of an intersection introduces complications, particularly when comparing the development of an intersection to a roadway, as well as one intersection to another. Although not ideal, displacement with time is considered to be the better option in this case.

In Figure 3.27 there are some erratic readings, at site one and two, between days 20 and 40, some of which have larger magnitudes than the accepted accuracy of the levelling system of 0.5 mm. In both intersections, at sites one and three, the step like behaviour of the displacements can be seen between days eight and 13 during the time when the splits were being developed.

3.7.1 Site performance summary colliery 'D' area one

Coalfield	: Witbank	Seam	: 2 Seam
Sites	: Four	Positions	: Two intersections two roadways
Road widths	: 6.0 m	Pillar widths	: 6.0 m Mining height: 2.1 m
Depth	: 50 to 60 m	Mining method	: Conventional drill and blast

Roof strata : Laminated sandstone and shale with highly variable bedding thicknesses.

Support : 1.5 m x 15 mm diameter spiral bars with full column resin in 22 mm diameter holes. Four bolts per row with rows 1.5 m apart.

Performance : Indications are that displacement occurred in the roof strata when the face was advanced with the blast, increasing the unsupported roof span up to a maximum of 3.5 m. This resulted in open parting planes or fractures being present as close as 0.5 m from the face prior to the installation of the support and instrumentation. These openings appeared to be mainly within the initial 0.4 m of the roof. By enlarge, the roof displacements were contained within the bolt horizon. The support system appeared to work well.

At the second area monitored at colliery 'D' both the support system and mining method were different. The support pattern and tendon type remained the same as in area one, however, the resin was reduced to two 19 x 380 mm cartridges. This resulted in a partial column resin bond length of approximately 1.04 m This left the initial 0.4 m of roof bolt in from the roof skin resin free. Mining was carried out using a continuous miner.

Four of the five sites were intersections. The intention was to install 0.1 X 0.1 x 0.9 m wooden headboards in two intersections to determine what affect this had on the roof behaviour. Unfortunately, due to a shortage of headboards at the time, they were only installed at site one. Adding the headboards reduced the effective roof bolted horizon from 1.45 m to 1.35 m. Backup levelling was installed at four of the five sites.

Witbank 2 Seam

Colliery 'D'

Drill and blast section

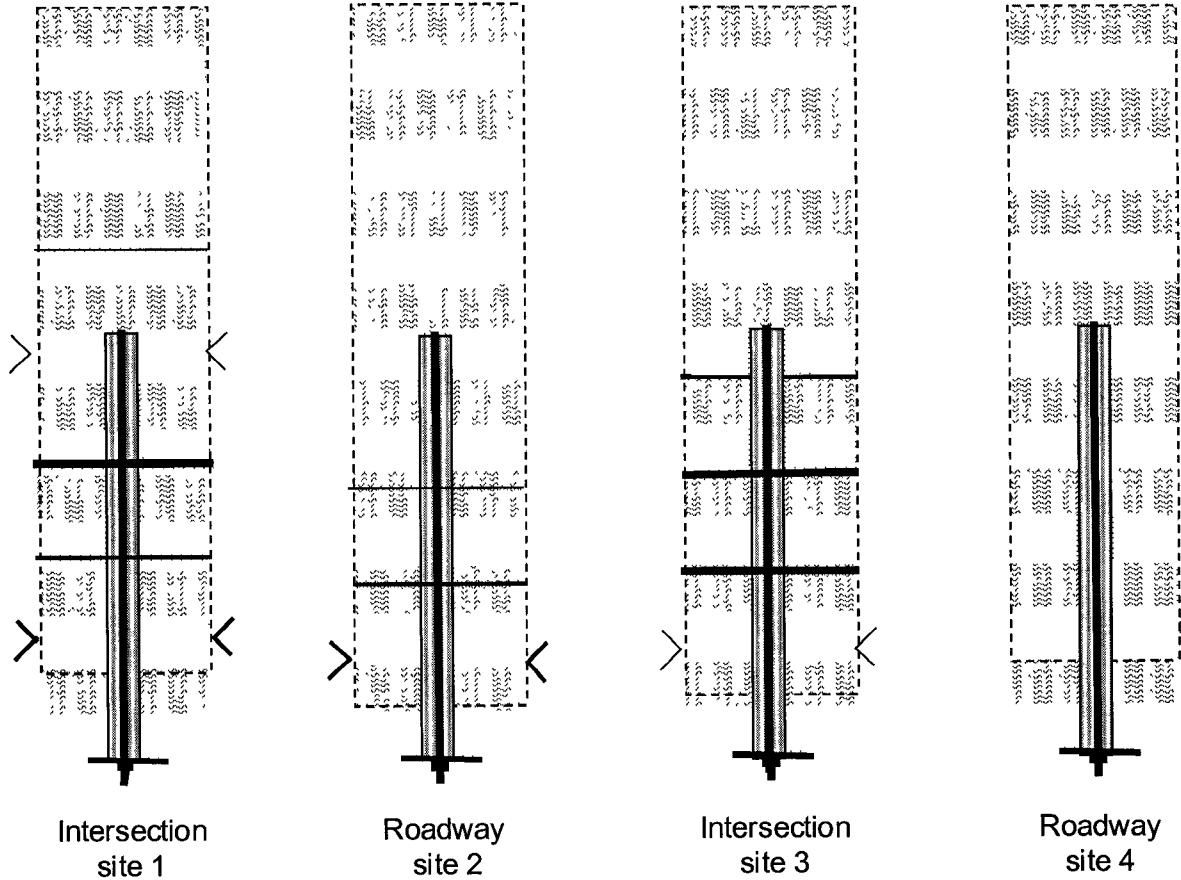

Roof : Laminated sandstone and shale with highly variable bedding thicknesses

Support : 1.5 m x 15 mm diameter spiral bars in 22 mm diameter holes with full column resin. Four bolts per hole with rows 1.5 m apart.

Figure 3.26. Colliery 'D' area 1 comparative roof behaviour

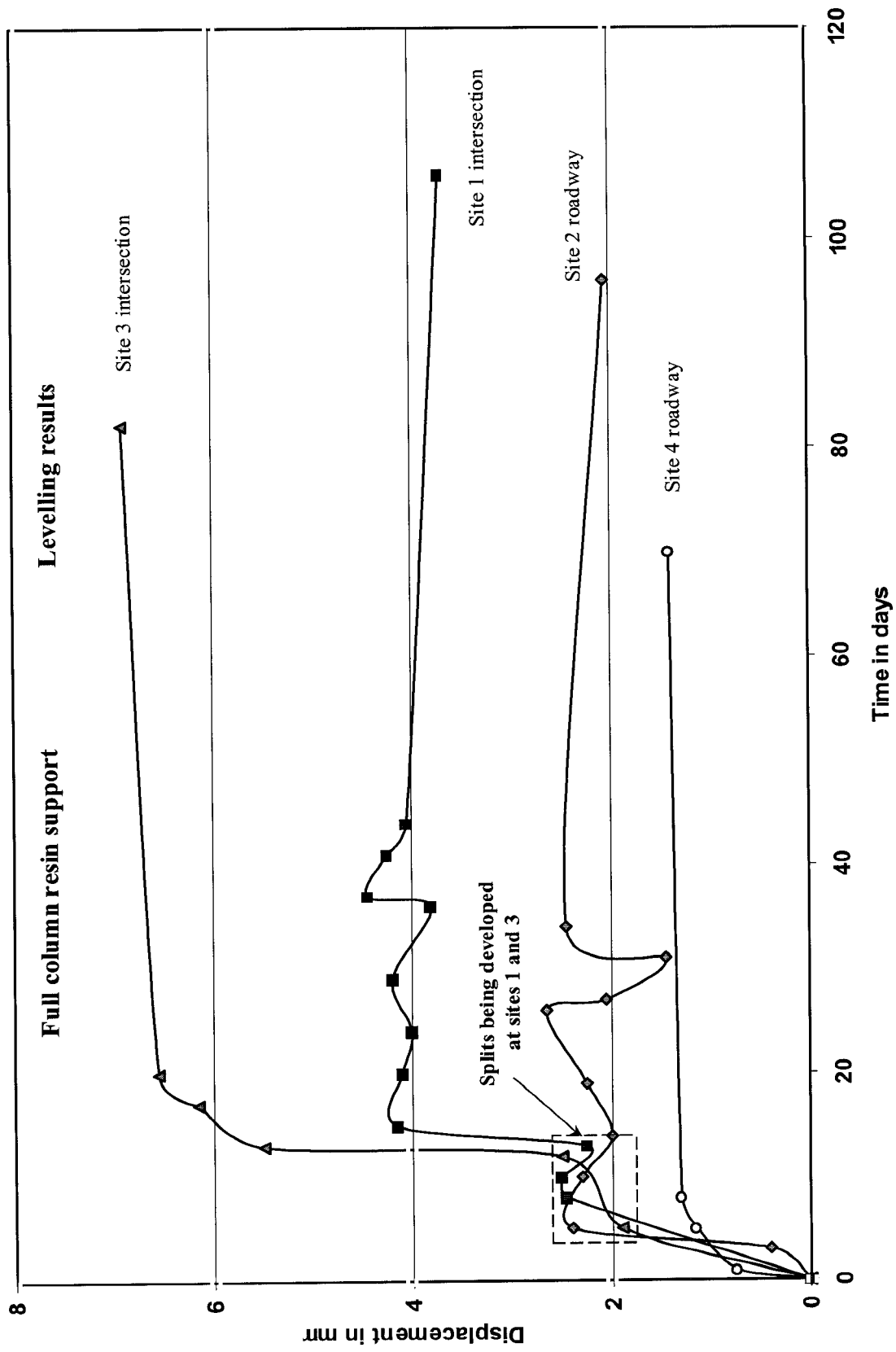

Figure 3.27. Colliery 'D' area 1 comparison of roof skin displacement

In the continuous miner cutting cycle approximately half the road width was mined for 7.0 m before the support was installed. The support consisted of two bolts per row with the rows 1.5 m apart. The adjacent side of the roadway was then mined up to the face after which the additional two bolts were added to each row.

Only two suspected kickbacks, both only just exceeding 0.5 mm were recorded. However, both kickbacks, picked up at sites one and four (Figures 3.28 and 3.31), have been excluded from the results for the following reasons.

- (a) They are high in the roof at 1.0 and 1.3 m respectively without there being any indication of openings below them nearer to the roof skin.
- (b) They are inconsistent, and were not recorded when readings were taken on days C and D.
- (c) The kickback at site four did not always meet the criterion of having an opening above it equal to, or larger than it.

At three of the four sites the levelling results were close to the values indicated by the lowest anchor in the sonic probe string. The exception was site three (Figure 3.30) where the levelling results were nearly 4.0 mm larger, indicating the presence of additional displacements below the sonic probe bottom anchor.

In the intersection with the headboards, site one (Figure 3.28), there are indications of some small displacements in excess of 1.0 mm above the bolt horizon, up to the 2.5 m elevation. The resin column in the bolt horizon performed well, maintaining the integrity of the strata in this region. There were however large displacements totalling 9.0 mm in the 0.3 m immediate skin of the roof below the resin column. These displacements occurred relatively quickly once the splits were mined. Contributing factors could have included a lack of stiffness of the headboard and irregular contact with the roof. However, since 80 per cent of the total displacement took place within the first four days, a more likely cause could have been insufficient tension applied to the bolts during installation. Timber shrinkage with time is unlikely to have had any real effect over such a short time period.

In the intersection at site two (Figure 3.29), the total relaxation of 12 mm, at the lowest anchor was identical to site one, as was the stable elevation at 2.5 m into the roof. The behaviour of the roof strata was however completely different. The displacements within the 2.5 m zone tended to be more linear. The resin column within the bolt horizon appeared to be ineffective as the two largest displacements occurred within this region. A large portion, approximately 75 per cent, of the final displacement occurred within 24 hours when the face had advanced 7.0 m and the first split had holed through.

When compared to the other two intersections at sites three and four (Figures 3.30 and 3.31) with the same support systems, the site two (Figure 3.29) intersection roof strata was by far the most active. The apparent ineffectiveness of the resin bond column suggests that the support may not have been correctly installed. The levelling results agree fairly closely with the sonic probe bottom anchor, with the exception of day 'A' which is so far out that it is in all probability an erroneous reading.

The overall roof strata behaviour at site three (Figure 3.30) was similar to that at site 1. The resin column appears to have maintained the integrity of the roof strata within its region of influence. The largest displacements were below the resin column. The levelling results indicate the presence of additional displacements of approximately 4.0 mm situated within 0.1 to 0.2 m of the immediate roof skin. This is not included on the strata column diagram and would increase the total relaxation to at least 10 mm. Unlike sites one and two, there is no evidence of displacements above the 1.9 m elevation.

Section of strata column under investigation

Legend

Day 1 installation at 0.5 m

- A = day 2 (no face advance)
- B = day 3 (face advance 7 m)
- C = day 4 (face advance 7 m)
- D = day 8 (face advance 28 m)
(splits holed through)
- E = day 59 (face advance 158 m)

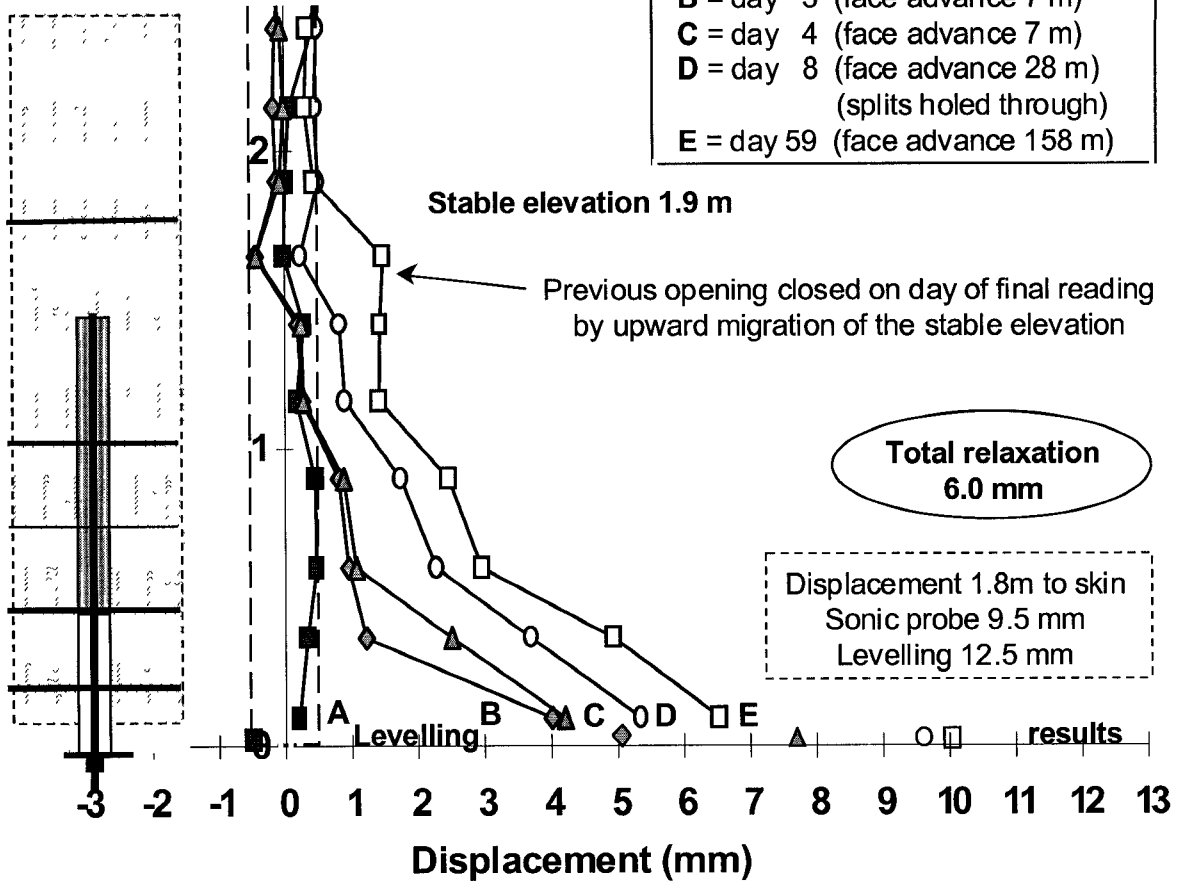

Notes

Coalfield : Witbank **Seam :** 2 seam **Position :** Intersection

Roof : Laminated sandstone & shale with highly variable bedding thicknesses.

Support : 1.5 m x 15 mm spiral bars with partial column resin in 22 mm diameter holes. Four bolts per row with rows 1.5 m apart.

Layout : Depth 55 to 60 m **Roadway :** 6.0 m **Pillar :** 6.0 m

Mining : Continuous miner **Mining height :** 2.1 m

Although the displacements extend to about 0.3 m above the bolt horizon the resin column was effective in maintaining the roof strata integrity. Most of the displacement occurred close to the roof skin below the resin column.

Figure 3.30. Colliery 'D' area 2 site 3 (intersection)

**Section of strata column
under investigation**

Legend

Day 1 installation at 0.5 m

- A = day 2 (face advance 5 m)
- B = day 3 (splits holed through)
- C = day 4 (splits holed through)
- D = day 8 (splits holed through)
- E = day 59 (splits holed through)

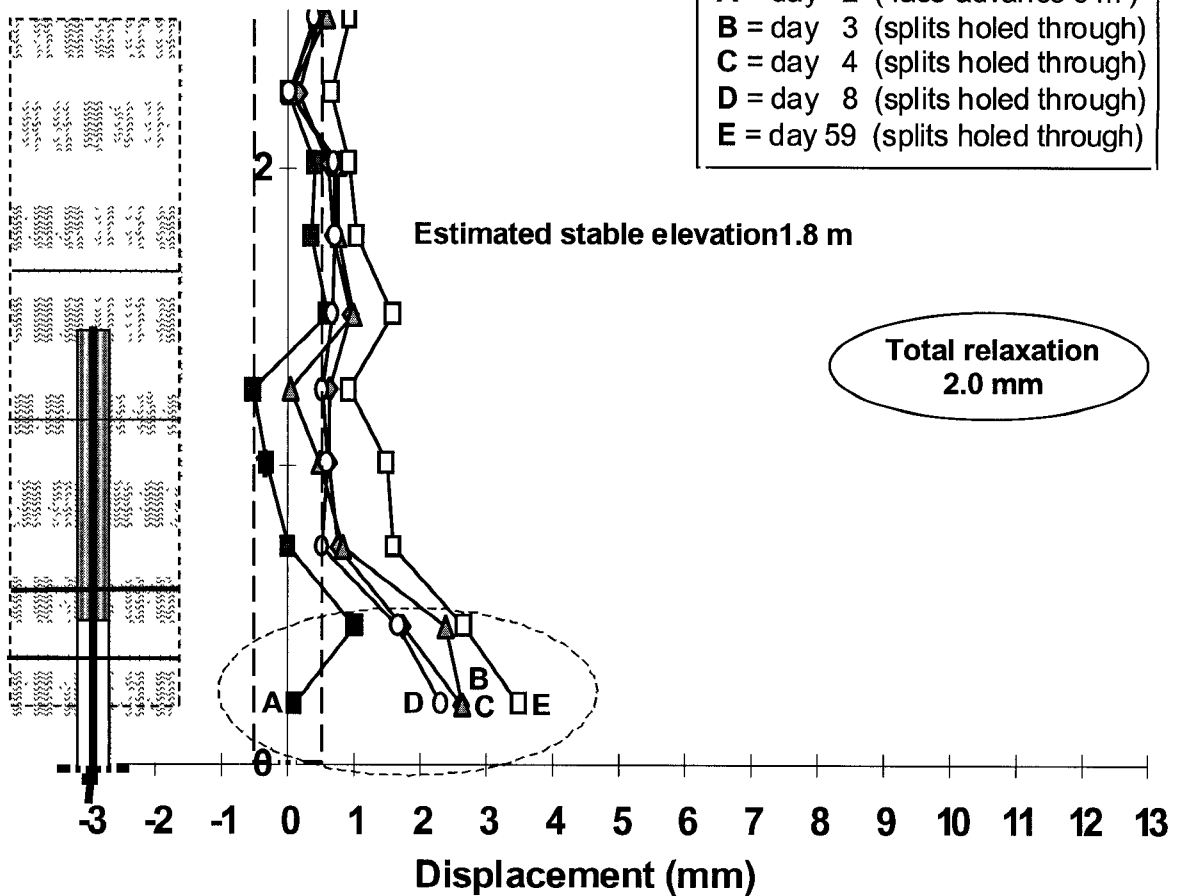

Notes

Coalfield : Witbank **Seam** 2 seam **Position** Intersection

Roof : Laminated sandstone & shale with highly variable bedding thicknesses.

Support : 1.5 m x 15 mm spiral bars with partial column resin in 22 mm diameter holes. Four bolts per row with rows 1.5 m apart.

Layout : **Depth** 55 to 60 m **Roadway** 6.0 m **Pillar** 6.0 m

Mining : Continuous miner **Mining height** 2.1 m

The displacements extended to about 0.3 m above the bolt horizon. The resin column effectively maintained the integrity of the roof strata within its influence with larger displacements occurring below it.

Figure 3.31. Colliery 'D' area 2 site 4 (intersection holed into)

The support in the intersection at site four (Figure 3.31) also performed well. The displacements were limited to the 1.8 m elevation and the total relaxation, recorded at 2.0 mm, was the lowest of all four intersections. However, since there was no levelling backup at this site it is not known if there were additional displacements in the immediate roof below the bottom sonic probe anchor.

The kickback, indicated close to the roof skin on day 'A,' was not recorded in any of the subsequent readings. This suggests that it was probably due to an error in reading although the initial displacement above it did meet the criterion of being equal to, or very slightly larger than the kickback itself.

Site five (Figure 3.32) was in a roadway approaching a dyke. The road width was reduced to approximately 5.0 m which resulted in the roof bolts being closer together in the rows. Although there appears to be small displacements up to the 2.0 m elevation, the majority of the displacements were contained within the initial 1.2 m of roof strata and were 2.5 mm in total. Although slightly higher in value, the levelling results agreed fairly closely with the bottom sonic probe anchor.

For comparison purposes the results of all five sites are grouped together in Figure 3.33. The strata performance at sites three, four and five were similar showing the roof to have been active below the 2.0 m elevation, approximately 0.5 m above the bolted zone. As previously mentioned, the roof behaviour at the intersections at sites one and two produced larger displacements than at the intersection at site three.

The total relaxation within the initial 1.8 m of roof strata, as recorded by the levelling results at four of the five sites, have been plotted together and are presented in Figure 3.34. The overall relaxation at sites one and two were approximately 10 and 20 per cent higher than the site three values.

3.7.2 Site performance summary colliery 'D' area two

Coalfield	: Witbank	Seam	: 2 Seam
Sites	: Five	Positions	: Four intersections one roadway
Road widths	: 6.0 m (5.0 m site five)	Pillar widths	: 6.0 m Mining height : 2.1 m
Depth	: 50 to 60 m	Mining method	: Continuous miner.

Roof strata : Laminated sandstone and shale with highly variable bedding thicknesses.

Support : 1.5 m x 15 mm diameter spiral bars with partial column resin in 22 mm diameter holes. Four bolts per row with rows 1.5 m apart.

Performance : There was no acceptable evidence of pre-existing openings in the roof prior to the installation of the support and instrumentation. In general, there were small displacements above the bolt horizon up to the 2.0 to 2.5 m elevations. There were also small displacements within the resin bond horizon with somewhat larger displacements in the unbonded 0.3 to 0.4 m of immediate roof. The exception was site two where the major displacements were within the resin bond horizon. The overall performance of the only intersection with headboards indicated that 75 per cent of the displacements were within the 0.3 m of unbonded immediate roof

The last area investigated at Colliery 'D' was in a continuous miner section. The support pattern remained the same. The support system was changed to 1.5 m x 18 mm rebar installed in the smallest hole diameter of 22 mm, using two 19 mm x 380 mm resin cartridges. This resulted in full column resin support. The difference between this support and the support installed in area one, apart from the increase in the cross sectional area of the steel tendon by approximately 26 per cent, was the use of 200 x 200 mm dome washers in place of the usual 150 x 150 mm washers.

Section of strata column under investigation

Legend

Day 1 installation at 0.5 m

- A = day 4 (face advance 5 m dyke exposed)
- B = day 6 (face advance 5 m dyke exposed)
- C = day 11 (face advance 11 m, through dyke)
- D = day 14 (face advance 11 m, through dyke)

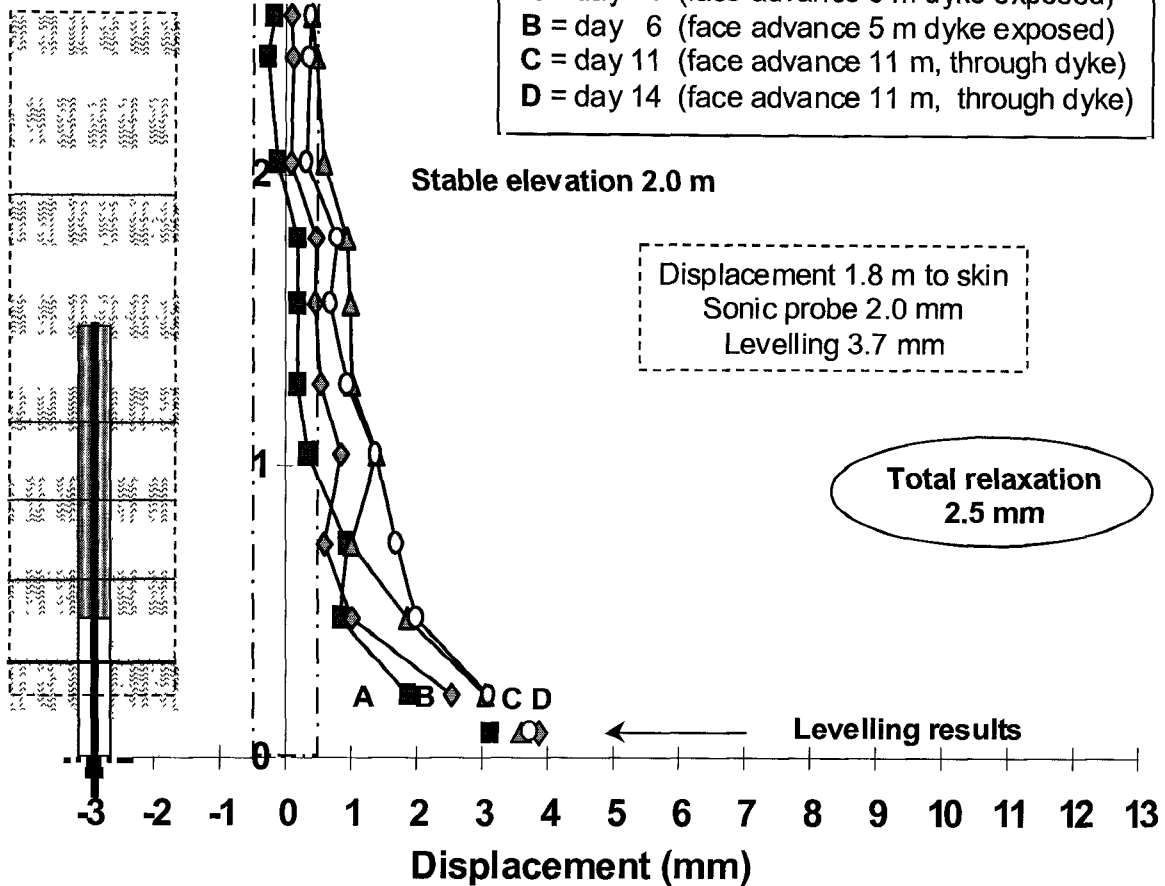

Notes

Coalfield : Witbank **Seam** 2 seam **Position** Roadway

Roof : Laminated sandstone & shale with highly variable bedding thicknesses.

Support : 1.5 m x 15 mm spiral bars with partial column resin in 22 mm diameter holes. Four bolts per row with rows 1.5 m apart.

Layout : Depth 55 to 60 m **Roadway** 5.0 m **Pillar** 6.0 m

Mining : Continuous miner **Mining height** 2.1 m

The displacements extended to about 0.4 m above the bolt horizon. The resin column effectively maintained the integrity of the roof strata within its influence.

Figure 3.32. Colliery 'D' area 2 site 5 (roadway mining through dyke)

Witbank 2 Seam

Colliery 'D'

Continuous miner section

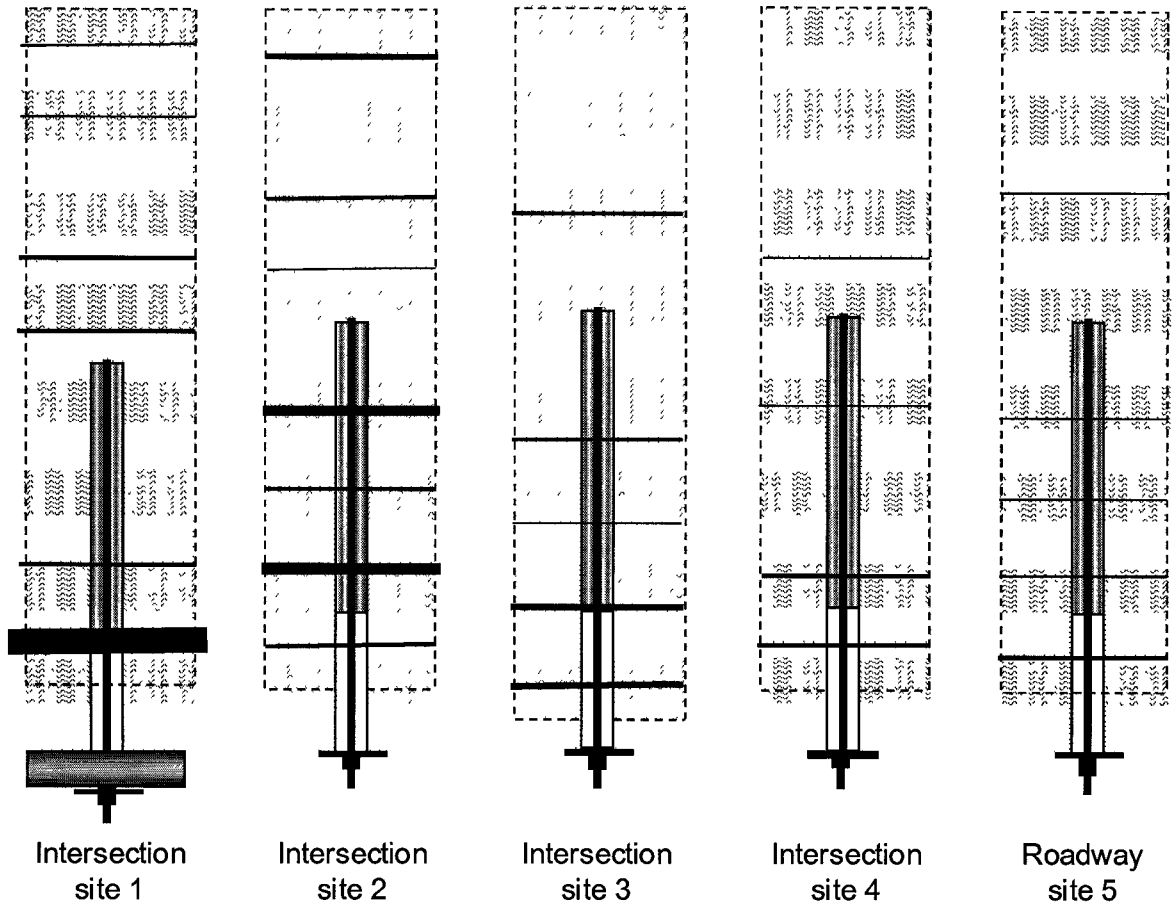

Roof : Laminated sandstone and shale with highly variable bedding thicknesses

Support : 1.5 m x 15 mm diameter spiral bars in 22 mm diameter holes with partial column resin. Four bolts per row with rows 1.5 m apart.

Figure 3.33. Colliery 'D' area 2 comparative roof behaviour

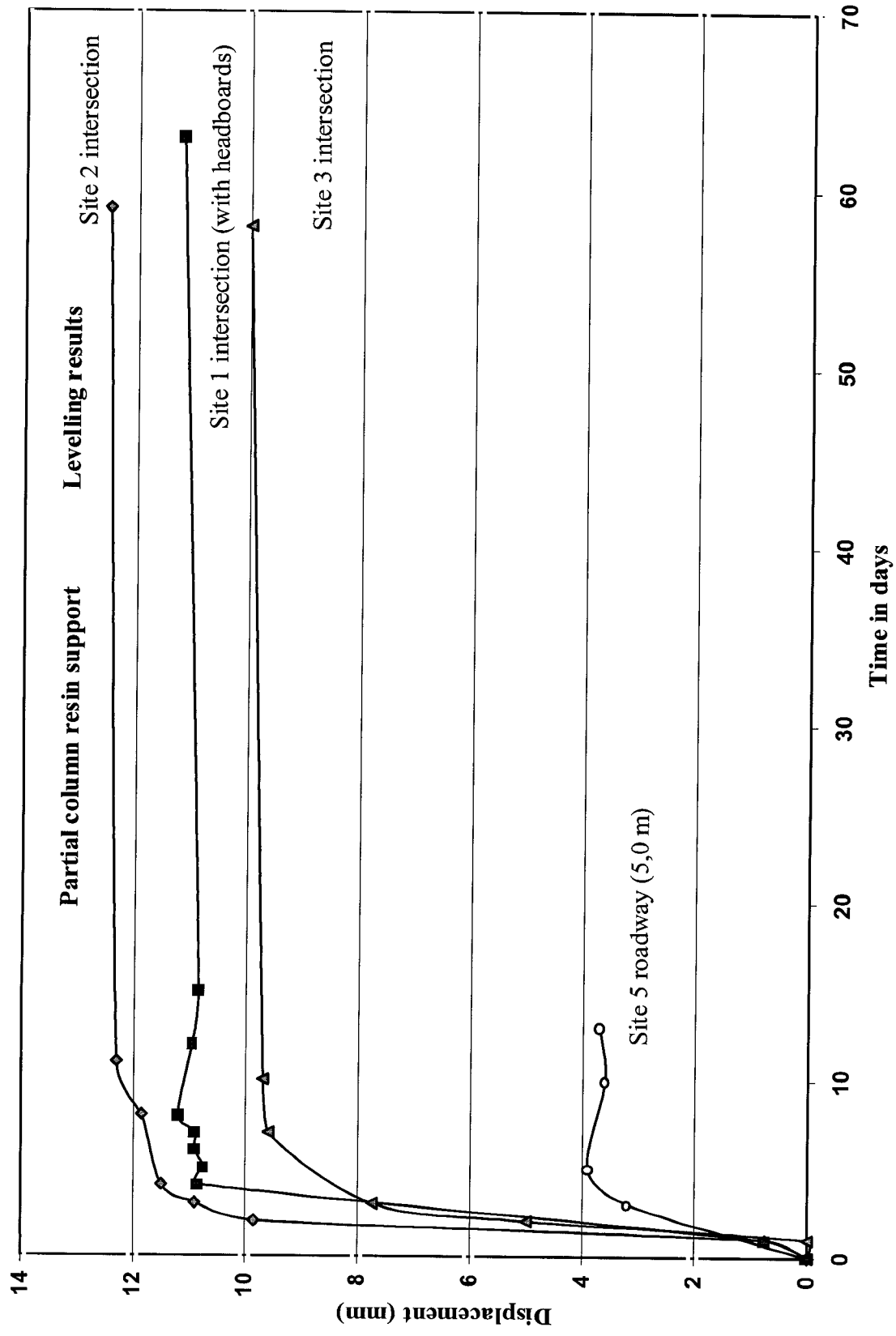

Figure 3.34. Colliery 'D' area 2 comparison between roadway and intersection roof skin displacement

The typical set of three sites was monitored, one intersection and two adjacent roadways. At site three after the installation of the instrumentation, the blind end of the roadway was not advanced. It was holed into from the other side. There was no backup levelling at any of the three sites.

There was very little displacement recorded at any of the sites as indicated in Figures 3.35, 3.36 and 3.37. There were no indications of any kickbacks in this area. The difference between the roof behaviour in the roadways and the intersection was hardly discernible. The stable elevation of the intersection increased slightly, from on average less than 1.0 m in the roadways to about 1.2 m, with a total relaxation of 1.0 mm. All the displacements recorded were well within the bolted zone indicating that the support had performed well. The comparative roof behaviour of the three sites in area three is presented in Figure 3.38.

3.7.3 Site performance summary colliery 'D' area three

Coalfield	: Witbank	Seam	: 2 Seam
Sites	: Three	Positions	: One intersection two roadways
Road widths	: 6.0 m	Pillar widths	: 6.0 m Mining height : 2.1 m
Depth	: 50 to 60 m	Mining method	: Continuous miner

Roof strata : Laminated sandstone and shale with highly variable bedding thicknesses.

Support : 1.5 m x 18 mm diameter rebars with full column resin in 22 mm diameter holes. Four bolts per row with rows 1.5 m apart.

Performance : There was no evidence of pre-existing openings in the roof prior to the installation of the support and instrumentation. In general there were only a few small displacements all contained within the bolt horizon. The support system appeared to work very well.

3.8 Colliery ' E '

Colliery 'E' was the last colliery investigated. Five sites were monitored in the gateroads and associated splits at the edge of a shortwall panel. Mining was by continuous miner. The laminated sandstone roof was supported by 1.8 m long 16 mm diameter full column resin bolts. The support pattern was four bolts per row with the bolts 1.0 m apart and 1.5 m between rows. Although backup levelling was attempted, it proved impractical to monitor due to the installation of the belt and the dumping of rubble. In addition to monitoring the effects of the development of the roadways, attempts were also made to monitor the dynamic effects of the approaching shortwall face.

Overall very little if any displacement was recorded as the roof remained stable throughout the mining process. The only site to record what appeared to be a real displacement was site one, Figure 3.39. Here a total relaxation of approximately 1.0 mm occurred within 0.3 m of the roof skin. The apparent kickback at the 1.2 m elevation was disregarded, as it did not meet the criterion of having an equal value displacement above it. The results from the other four sites are presented in Figures 3.40, 3.41, 3.42 and 3.43.

**Section of strata column
under investigation**

Legend

Day 1 installation at 0.5 m

- A = day 3 (face advance 6 m)
- B = day 8 (face advance 27 m)
(splits mined)
- C = day 15 (face advance 27 m)
- D = day 29 (face advance 84 m)

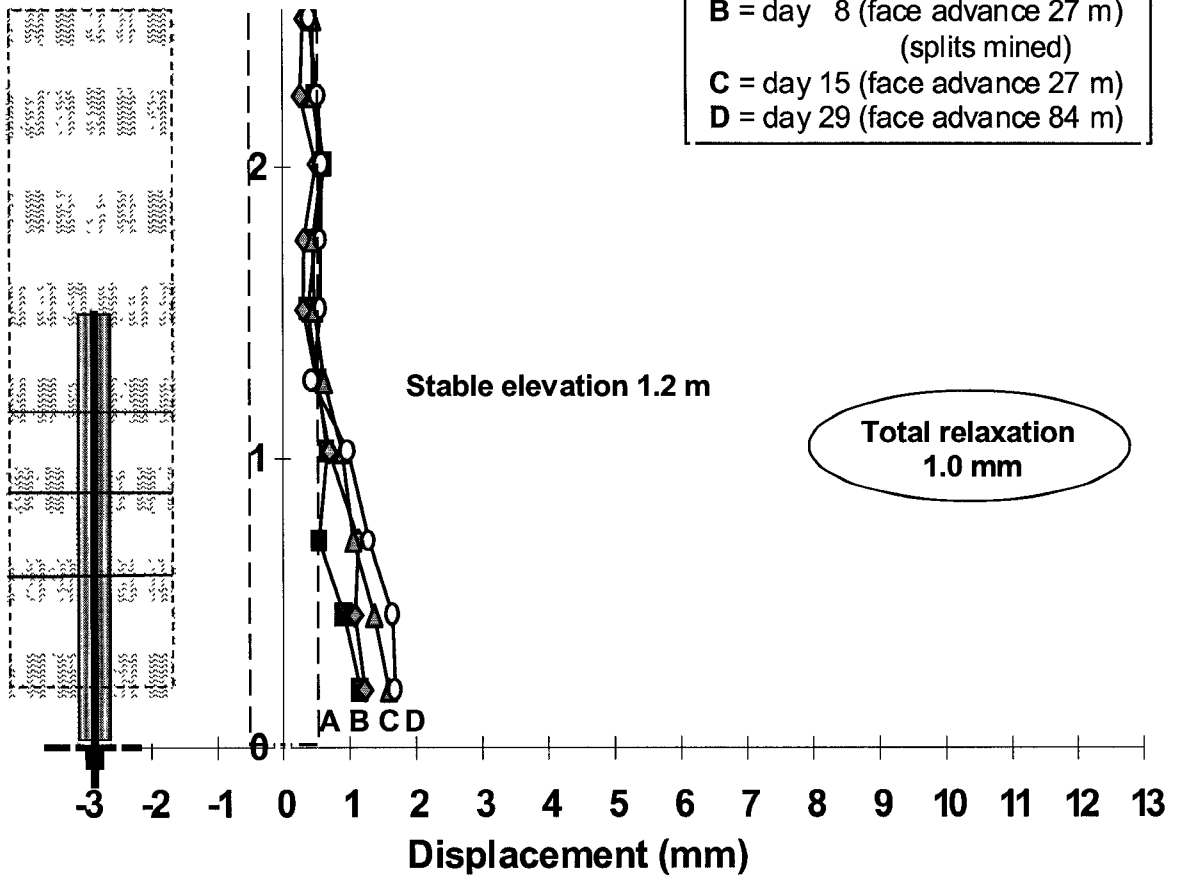

Notes

Coalfield :Witbank **Seam** 2 seam **Position** Intersection

Roof : Laminated sandstone & shale with highly variable bedding thicknesses.

Support : 1.5 m x 18 mm rebars with 200 mm x 200 mm dome washers
full column resin in 22 mm diameter holes.
Four bolts per row with rows 1.5 m apart.

Layout : Depth 55 to 60 m **Roadway** 6.0 m **Pillar** 6.0 m

Mining : Continuous miner **Mining height** 2.1 m

Very small displacements all within the bolt horizon.

Figure 3.35. Colliery 'D' area 3 site 1 (intersection)

**Section of strata column
under investigation**

Legend

Day 1 installation at 0.5 m

- A** = day 3 (face advance 17 m)
- B** = day 6 (face advance 21 m)
- C** = day 13 (face advance 21 m)
- D** = day 27 (face advance 77 m)

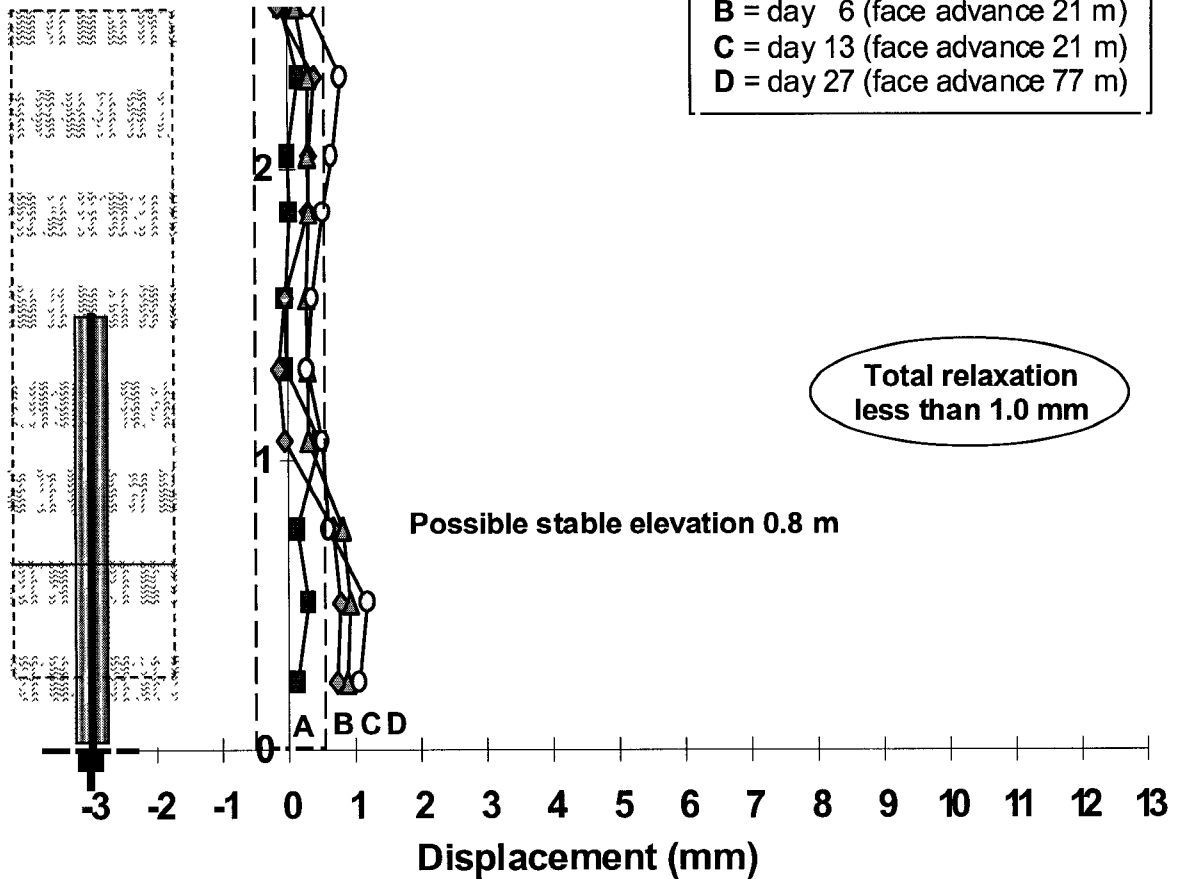

Notes

Coalfield :Witbank **Seam** 2 seam **Position** Roadway

Roof : Laminated sandstone & shale with highly variable bedding thicknesses.

Support : 1.5 m x 18 mm rebars with 200 mm x 200 mm dome washers
full column resin in 22 mm diameter holes.
Four bolts per row with rows 1.5 m apart.

Layout : **Depth** 55 to 60 m **Roadway** 6.0 m **Pillar** 6.0 m

Mining : Continuous miner **Mining height** 2.1 m

Hardly any displacements recorded.

Figure 3.36. Colliery 'D' area 3 site 2 (roadway)

**Section of strata column
under investigation**

Legend

Day 1 installation at 0.5 m

- A** = day 4 (no face advance)
- B** = day 13 (face half holed)
- C** = day 25 (face holed through)

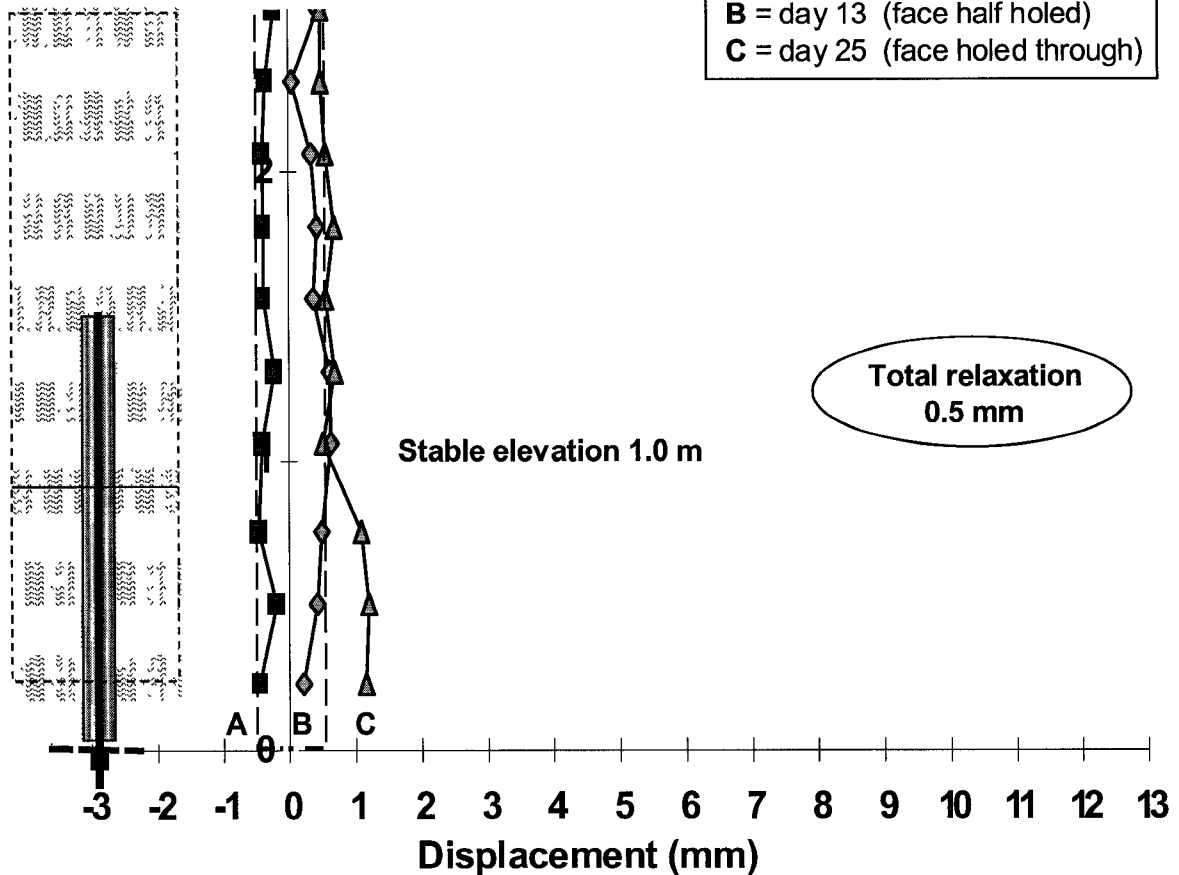

Notes

Coalfield :Witbank **Seam** 2 seam **Position** Roadway

Roof : Laminated sandstone & shale with highly variable bedding thicknesses.

Support : 1.5 m x 18 mm re-bars with 200 mm x 200 mm dome washers
full column resin in 22 mm diameter holes.
Four bolts per row with rows 1.5 m apart.

Layout : **Depth** 55 to 60 m **Roadway** 6.0 m **Pillar** 6.0 m

Mining : Continuous miner **Mining height** 2.1 m

Hardly any displacements recorded.

Figure 3.37. Colliery 'D' area 3 site 3 (roadway blind end holed into)

Witbank 2 Seam

Colliery 'D'

Continuous miner section

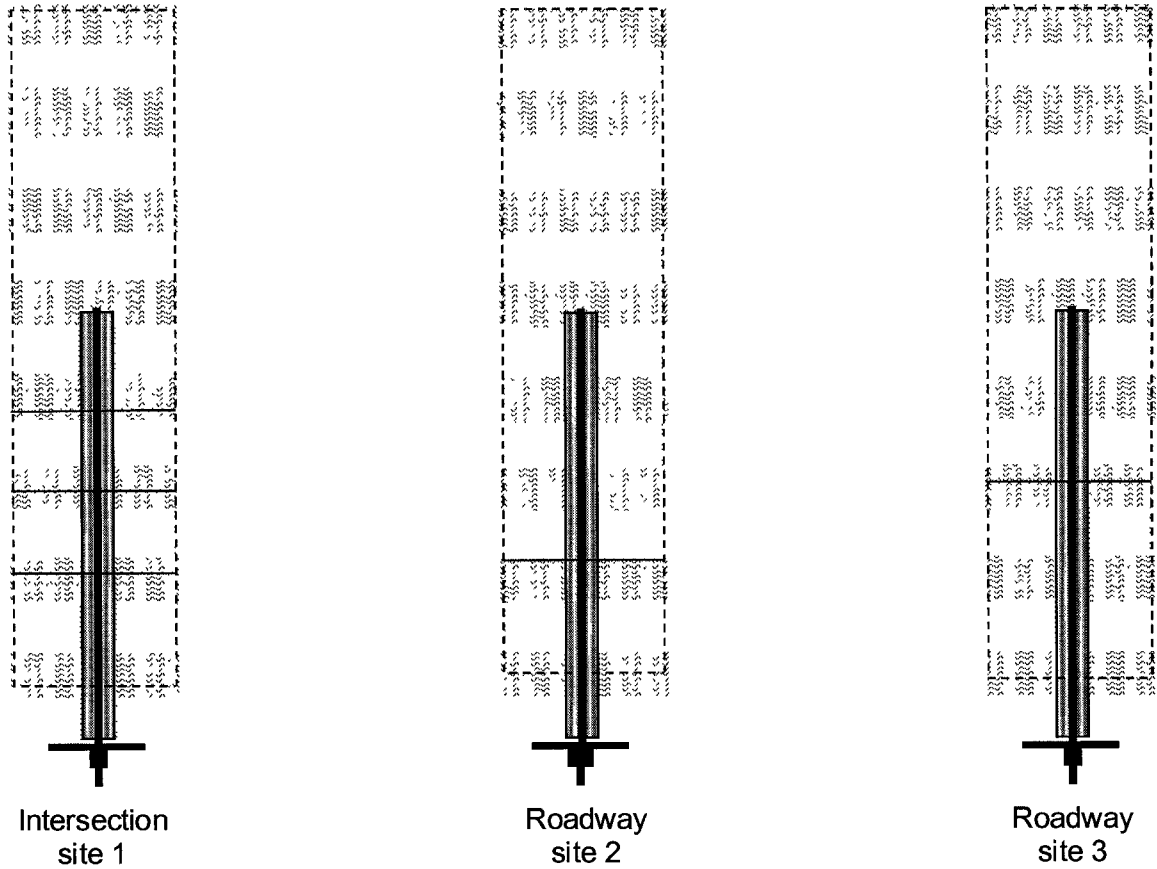

Roof : Laminated sandstone and shale with highly variable bedding thicknesses

Support : 1.5 m x 18 mm diameter re- bars in 22 mm diameter holes with full column resin and 200 mm x 200 mm dome washers.
Four bolts per row with rows 1.5 m apart.

Figure 3.38. Colliery 'D' area 3 comparative roof behaviour

**Section of strata column
under investigation**

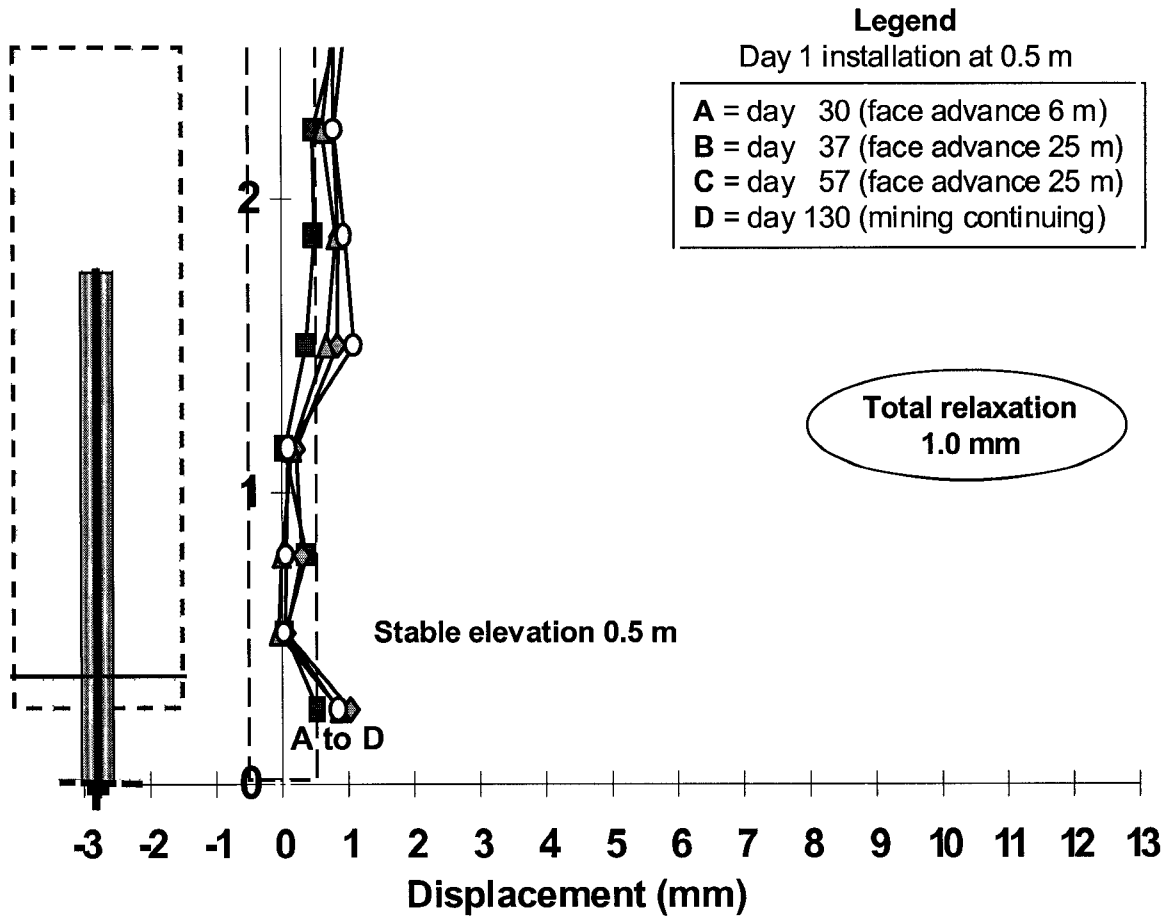

Notes

Coalfield :Highveld **Seam** 2 seam **Position** Shortwall gate road

Roof : Laminated sandstone

Support : 1.8 m x 16 mm full column resin bolts four in a row (1.0 m apart)
across the roadway, 1.5 m between rows.

Layout : **Depth** 50 m **Roadway** 6.5 m **Pillars** chain pillars 50 m centres

Mining : Continuous miner **Mining height** 3.0 m

Very small displacements were recorded

Figure 3.39. Colliery 'E' site 1 (gate road)

**Section of strata column
under investigation**

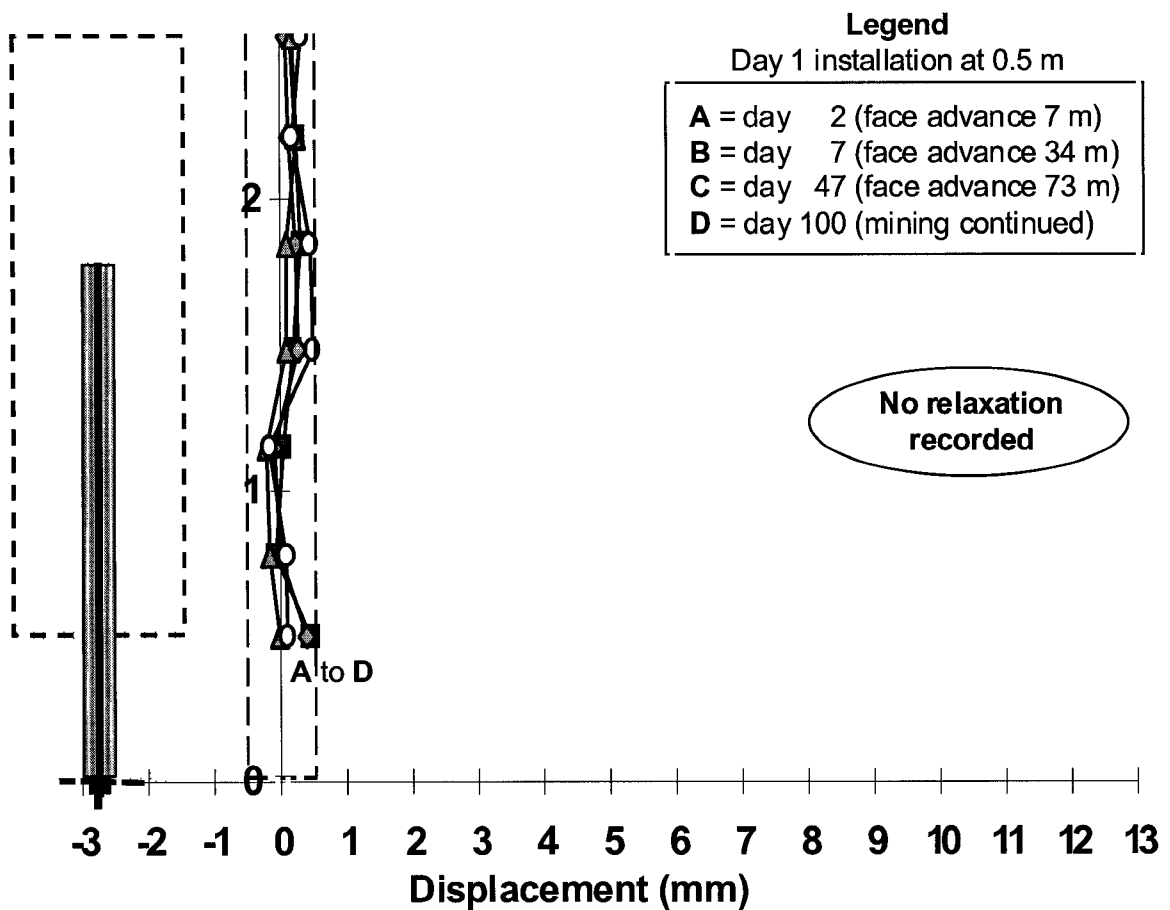

Notes

Coalfield :Highveld **Seam** 2 seam **Position** Shortwall gate road

Roof : Laminated sandstone

Support : 1.8 m x 16 mm full column resin bolts four in a row (1.0 m apart)
across the roadway, 1.5 m between rows.

Layout : **Depth** 50 m **Roadway** 6.5 m **Pillars** chain pillars 50 m centres

Mining : Continuous miner **Mining height** 3.0 m

No displacements were recorded

Figure 3.40. Colliery 'E' site 2 (gate road)

**Section of strata column
under investigation**

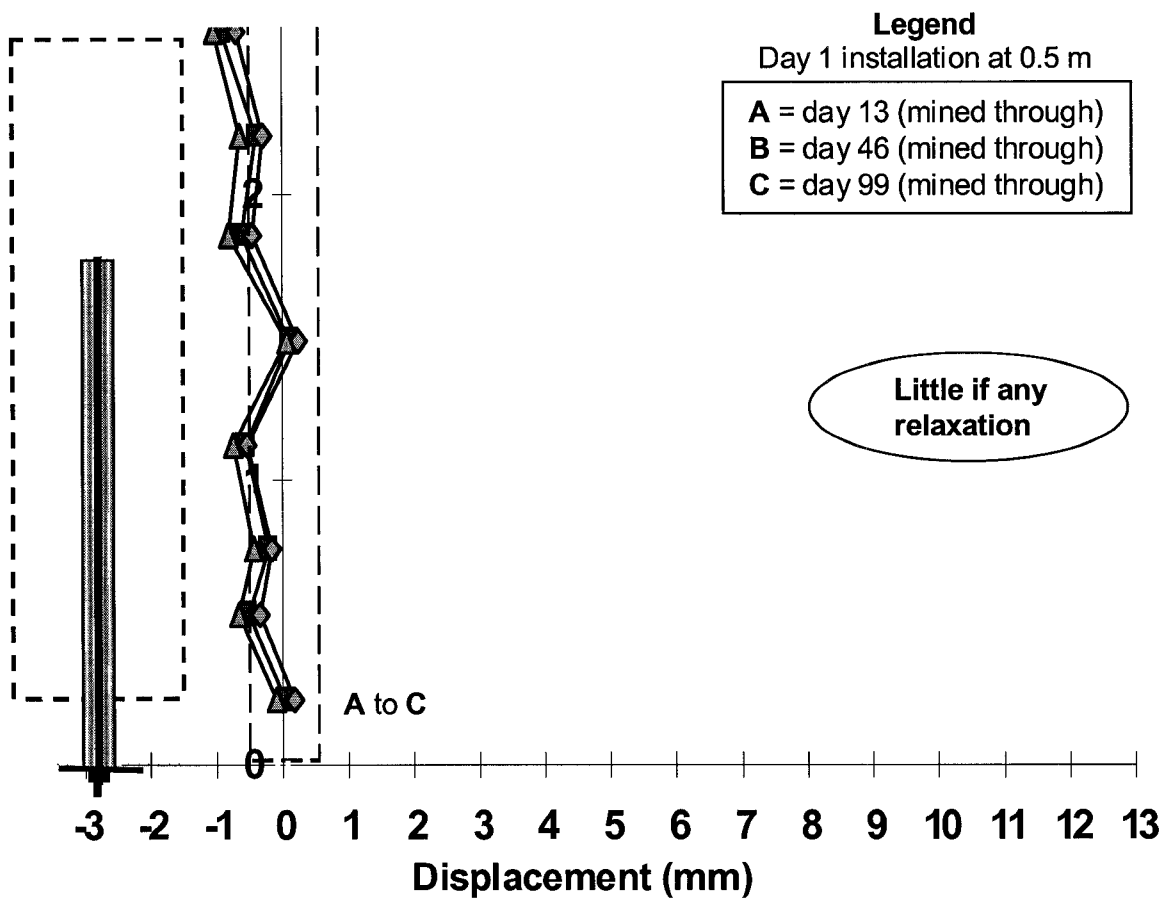

Notes

Coalfield :Highveld **Seam** 2 seam **Position** Shortwall gate road split

Roof : Laminated sandstone

Support : 1.8 m x 16 mm full column resin bolts four in a row (1.0 m apart)
across the roadway, 1.5 m between rows.

Layout : **Depth** 50 m **Roadway** 6.5 m **Pillars** chain pillars 50 m centres

Mining : Continuous miner **Mining height** 3.0 m

No displacements were recorded

Figure 3.41. Colliery 'E' site 3 (split between gate roads)

**Section of strata column
under investigation**

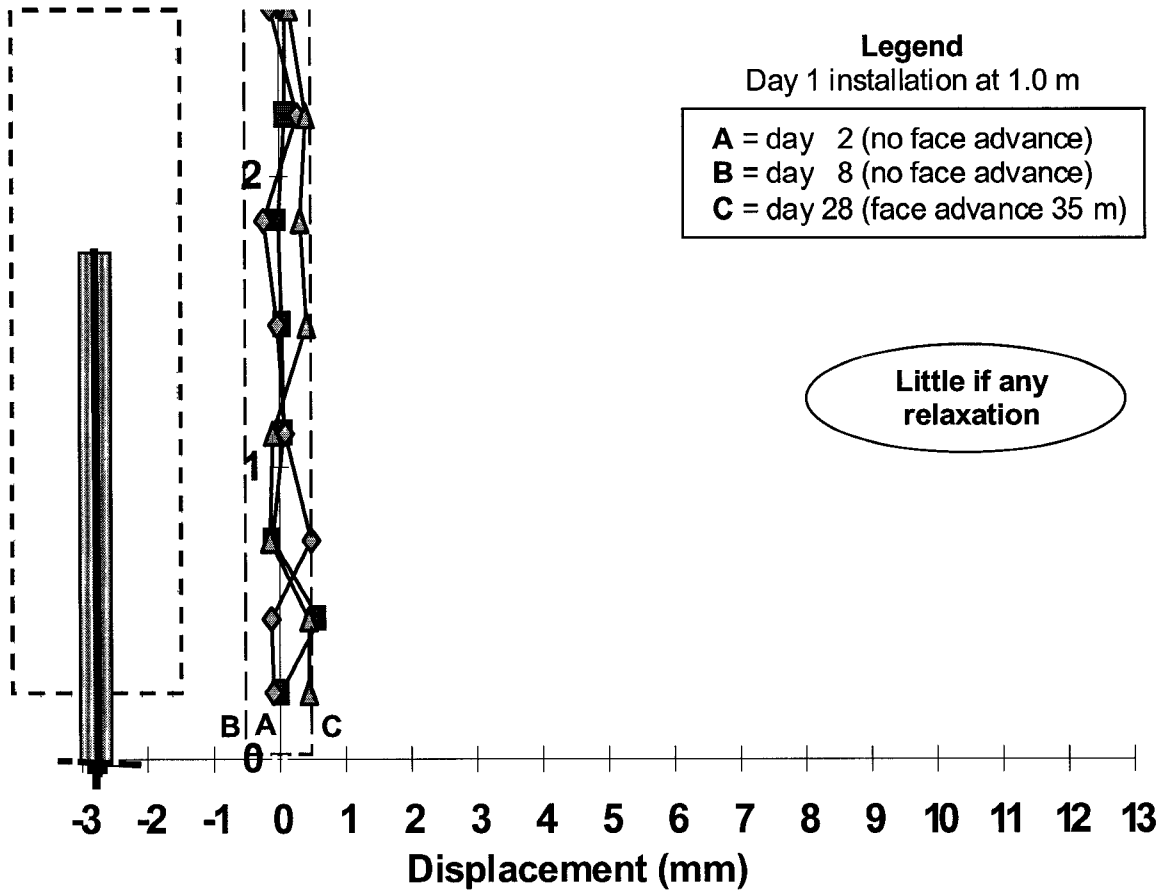

Notes

Coalfield :Highveld **Seam** 2 seam **Position** Shortwall gate road

Roof : Laminated sandstone

Support : 1.8 m x 16 mm full column resin bolts four in a row (1.0 m apart)
across the roadway, 1.5 m between rows.

Layout : **Depth** 50 m **Roadway** 6.5 m **Pillars** chain pillars 50 m centres

Mining : Continuous miner **Mining height** 3.0 m

No displacements were recorded

Figure 3.42. Colliery 'E' site 4 (gate road)

**Section of strata column
under investigation**

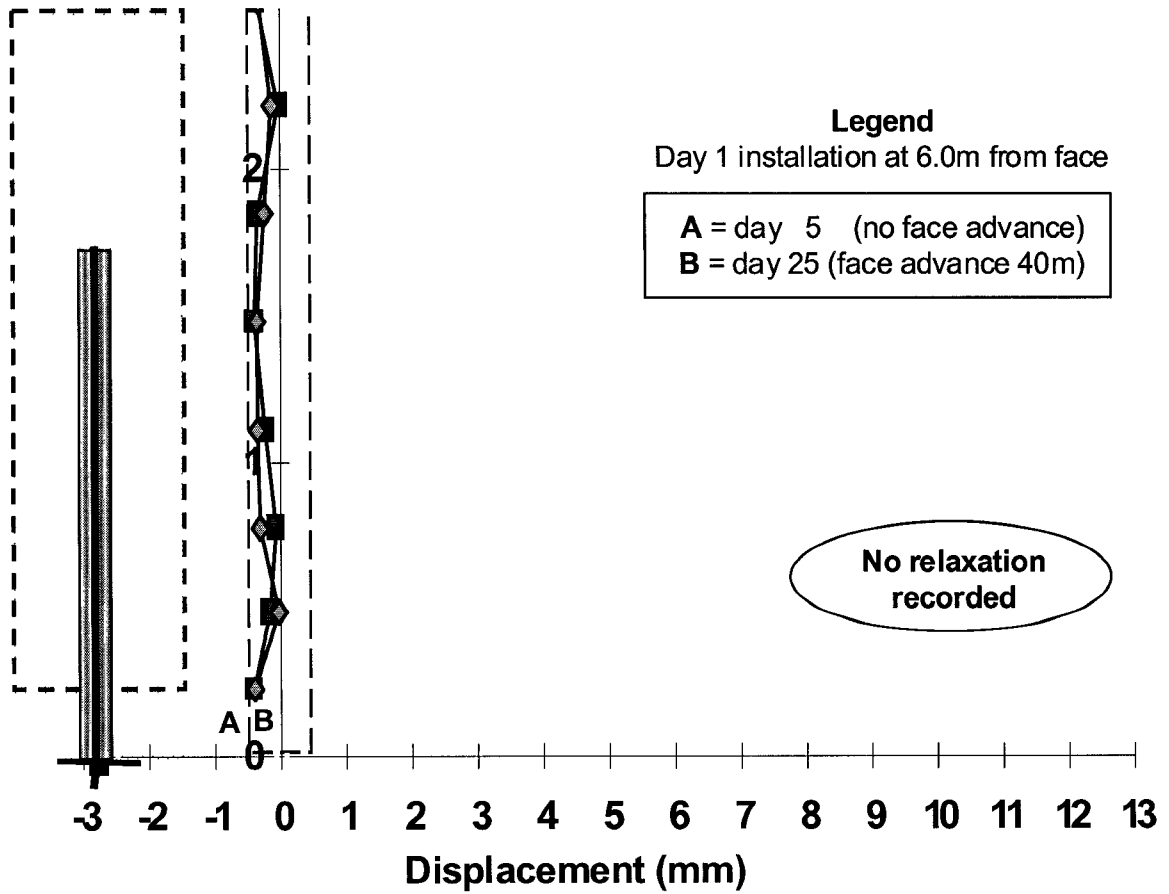

Notes

Coalfield :Highveld **Seam** 2 seam **Position** Shortwall gate road

Roof : Laminated sandstone

Support : 1.8 m x 16 mm full column resin bolts four in a row (1.0 m apart)
across the roadway, 1.5 m between rows.

Layout : **Depth** 50 m **Roadway** 6.5 m **Pillars** chain pillars 50 m centres

Mining : Continuous miner **Mining height** 3.0 m

No displacements were recorded

Figure 3.43. Colliery 'E' site 5 (roadway)

3.8.1 Site performance summary colliery 'E'

Coalfield	: Highveld	Seam	: 2 Seam
Sites	: Five	Positions	: Four roadways one split
Road widths	: 6.5 m	Pillar widths	: Ch. pil. 50 m centres Mining height: 3.0 m
Depth	: 50 m	Mining method	: Continuous miner

Roof strata : Laminated sandstone.

Support : 1.8 m x 16 mm diameter bolts with full column resin. Four bolts per row with bolts 1.0 m apart and 1.5 m between rows.

Performance : Only one site recorded a very slight relaxation of 1.0 mm. The support system, which was primarily designed to resist shear failure during the dynamic phase as the shortwall face advanced, appeared to be more than adequate.

3.9 Analysis of underground field measurements

In Table 3.1 the roof strata, mining method, support type and monitoring position of all the underground sites at the five collieries are listed. At colliery 'E', where four of the sites were completely stable, they have been recorded in a single line as "Roadway x 4". The background information with regard to the sonic probe results, levelling measurements and the stable roof elevations are also listed.

For comparison purposes the roadway and intersection information at each colliery or area within a colliery has been averaged. The stable roof elevations have been averaged in a similar manner. A breakdown of the displacements recorded between the 1.8 mm elevation and the lowest sonic probe anchor has been calculated for a more accurate comparison with the levelling results.

The approximate elevations and values of the kickbacks recorded are presented in Table 3.2. Of the 14 monitoring sites in drill and blast sections, at three different collieries, 13 sites recorded at least one kickback. The lack of kickbacks in the continuous miner sections indicates that the kickbacks were directly link to the drill and blast mining method. Their initiation is independent of the support type as these openings existed prior to the installation of any support.

At the monitoring sites where kickbacks occurred, the total relaxation, as recorded by both the sonic probe and backup levelling, does not include displacements attributable to any pre-existing openings. In order to assess the overall displacement or relaxation at the kickback sites, it was necessary to take the pre-existing openings or displacements into account. To do this it had to be assumed that all the pre-existing openings closed completely with time and face advance. The final value recorded by each kickback at a particular site was added to the relevant total relaxation recorded by the sonic probe to arrive at an adjusted value. These adjusted values were then averaged for the roadways and intersections at each colliery, in the same manner as in Table 3.1, and are listed in Table 3.2.

In Table 3.3 comparisons are made between the intersections and roadways with regard to the total relaxation and stable roof elevations. The kickback effects on the total relaxation are also examined.

In the total relaxation comparisons the sonic probe data was used. The percentage increase in the values recorded at the intersections, in relation to the roadways, were calculated and varied between 25 and 460 per cent. The overall average of the five different areas was 197 per cent. This indicates that, for a 40 per cent increase in the span taken across the diagonal of an intersection, relative to the roadway span, the magnitude of the displacements in the roof increased by a factor of three. This value was very close to the results derived from 3D numerical modelling of a 6.0 m wide roadway where the calculated increase was 2.8.

Table 3.2. Sonic probe relaxation results adjusted to incorporate any applicable kickback values

Colliery and Roof strata	Mining method	Support type	Monitoring Position	Kickback skin		Kickback higher		Probe relaxation (mm)		
				(m)	(mm)	(m)	(mm)	Total	Adjusted	Averages
A Shale	C M	Full column resin	Roadway					2.5		1.3
			Roadway				0.0			
B Coal roof 0.3 m shale then coal above	D&B	Partial column resin	Roadway	0.6	0.8	1.4	4.0	2.0	6.8	5.1
			Roadway	0.3	1.0	0.5	1.5	0.5	3.0	
			Roadway			1.0	1.3	2.5	3.8	
			Roadway Intersection	0.3	3.8			3.0	6.8	
			Intersection	0.3	1.0	1.0	2.0	4.0	7.0	
			Intersection	0.3	5.0			6.0	11.0	
C 0.3m coal with shale above	D&B	Mechanical end anchored	Roadway			2.0	0.8	1.5	2.3	1.7
			Roadway Intersection			2.0	0.5	0.5	1.0	
			Intersection	0.3	1.3	1.0	1.3	3.5	4.8	
			Intersection	0.3	1.3	1.8	0.8	1.0	3.1	
D Inter laminated sandstone and shale	D&B Area 1	Full column resin	Roadway					0.5		1.2
			Roadway Intersection	0.3	0.8			1.0	1.8	
			Intersection	0.3	0.5			6.5	7.0	
			Intersection	0.3	1.3	1.3	0.5	2.5	4.3	
E Sandstone	C M Area 3	Partial column resin	Roadway Intersection					2.5		2.5
			Intersection					2.0		
			Intersection					12.0		
			Intersection					12.0		
			Intersection					6.0		
E Sandstone	C M	Full column resin	Roadway					1.0		0.8
			Roadway Intersection					0.5		
			Intersection					1.0		
E Sandstone	C M	Full column resin	Roadway					1.0		0.2
			Roadway x 4					0.0		

The other factor linked to, and affected by an increase in span, is the height to which the openings migrate in the roof, i.e. the stable roof elevation. The intersections were again compared to the roadways with the differences being converted to percentages. These changes were relatively small varying between – 5.0 and 33 per cent with the overall average being 13 per cent.

The areas that exhibited the highest percentage change of around 30 per cent were areas one and three at colliery 'D'. Both areas were supported by full column resin bolts with an effective bolt length of 1.45 m. Although, in percentage terms, the changes appear relatively large the average stable elevations were the lowest recorded of the five areas where roadway and intersection comparisons could be made. Viewing the reactions of the five areas as a whole, the 40 per cent increase in span from the roadway width to the intersection diagonal had very little effect on the stable roof elevation. There was no evidence of a dramatic increase in the stable elevations as is the case in the high horizontal stress driven beam buckling mechanism experienced in the Australian collieries.

The kickback-adjusted total relaxation averages derived in Table 3.2 were compared with the original sonic probe recorded relaxations and are listed as percentage increases in Table 3.3. The three areas experienced increases of between 27 and 155 per cent with an overall average of 76 per cent. In terms of the overall average total kickback-adjusted relaxation, 42 per cent of the displacements occurred prior to the installation of the support.

The acquisition of this type of data would not have been possible without a high anchor density extensometer system such as the sonic probe. Other simple extensometer systems, including the back up survey levelling technique, are often limited to two anchor points. One anchor point is traditionally in the roof skin, which is compared to some other point in or above the bolted zone. These systems are in effect monitoring the total displacement or relaxation between the two points. It is evident from the data gathered in drill and blast sections with coal and or shale in the roof that these results could be misleading. If 42 per cent of the total displacement has already taken place prior to the installation of any instrumentation, the measurable amount of displacement required to produce an unsafe situation is reduced. If, as appears to be the case, we are dealing with relatively small values, compared to the United Kingdom and Australia, the use of visual indicators, such as tell tales in drill and blast sections, would require a higher degree of awareness and training if they are to perform their function.

During 1998 a drill and blast section in a colliery in Kwazulu Natal was visited to investigate the possibility of monitoring the roof using the sonic probe. The mine was experiencing problems with an immediate shale roof layer of between 0.5 and 0.75 m thick which collapsed soon after, or sometimes when, the face was blasted. In an attempt to consolidate this roof layer, horizontal holes were drilled approximately 30 m ahead of the face and a cementitious material was injected via the holes. Although this technique did not solve the roof stability problem an interesting phenomenon was observed. As the face was advanced the injected material was exposed in the ribsides and face by roof falls. Not only had it penetrated up to two pillars ahead of the face, it was also found to have penetrated into the roof of adjacent parallel roadways that were later developed. This indicated the presence of openings within the roof in the "solid" ground well ahead of the face. In places open partings up to 15 mm wide were observed, indicated by the thickness of the injected material.

This observation enhances the credibility of having pre-existing openings, in a drill and blast section, within 0.5 m of the face prior to the installation of the support as indicated by the kickback phenomenon.

Table 3.3. Total relaxation, kickback adjustments and stable roof elevation averages

Colliery and Roof strata	Mining method	Support type	Monitoring Position	Total relaxation averages	Intersection percentage increase	Kickback adjusted averages	Relaxation percentage increase	Stable roof elevation averages	Intersection percentage change
A Shale	C M	Full column resin	Roadway	1.3				0.6	
B Coal roof 0.3 m shale then coal above	D&B	Partial column resin	Roadway	2.0		5.1	155	2.1	
			Intersection	5.0	150	9.0	80	2.0	-5
C 0.3m coal with shale above	D&B	Mechanical end anchored	Roadway	1.0		1.7	70	2.2	
			Intersection	2.3	130	4.0	74	2.1	-5
D Inter laminated sandstone and shale	D&B	Full column resin	Roadway	0.8		1.2	50	1.3	
			Intersection	4.5	460	5.7	27	1.7	30
E Sandstone	C M	Partial column resin	Roadway	2.5				2.0	
			Intersection	8.0	220			2.2	10
	C M	Full column resin	Roadway	0.8				0.9	
			Intersection	1.0	25			1.2	33
	C M	Full column resin	Roadway	0.2				0.1	

Overall average percentage change

197

76

13

3.9.1 Time effects of a static face

Although each site was visited as often as possible particularly immediately after the instrumentation was installed, it was not always possible to make direct comparisons between a large portion of the sites. The main reasons include different face advance rates for drill and blast and continuous miner sections, and the erratic nature of particular mining sequences and breakdowns. From the relatively large data base established on the 29 sites, it was however possible to extract valuable information even though it may only have been recorded at a small number of sites. A typical example is the time effect on a static face.

All three examples were observed at colliery 'D'. At area one site two (Figure 3.23), in a drill and blast section three days after the installation of the instrumentation, a second set of sonic probe and levelling readings were taken. The face had not been advanced. The results of both monitoring methods showed that the roof 0.5 m from the face was also static during this period. At area three site three (Figure 3.37) in a continuous miner section, where the face was not advanced for four days, the sonic probe readings all fell within the accepted accuracy band indicating static roof conditions.

In area two at site five (Figure 3.32) in a continuous miner section, the conditions were different in so far as the face was advanced 5.0 m to expose a dyke where it remained static over a two day period. It was then advanced through the dyke to the 11 m position and again remained stationary for three days until the final set of readings were taken. At the 5.0 m position, both the sonic probe and levelling recorded an increase in displacement of approximately 0.8 mm over the two day period. At the 11 m face position, over a three day period, no additional displacements were recorded.

These results indicate the following: close to a static face (within 0.5 m), the roof does not deform significantly. If a face remains static, the roof within its zone of influence (approximately 5.0 m away) experiences some degree of creep with time. An area of roof outside the zone of influence of the face (11 m away) is not affected by the face irrespective of whether it is stationary or mobile.

3.9.2 Migration mechanism

In the vast majority of cases, the final height at which the displacements in the roof stabilised was fully developed a short distance behind the face. In the drill and blast sections, the stable elevation was reached after a single blast and the face advance had increased the unsupported span to 3.0 m on average.

In the continuous miner sections, it was difficult to accurately determine at what point the stable elevation had fully developed. The reason was that half the face was usually advanced by up to 7.0 m in a single cutting sequence. After the installation of the support, the other half of the face was then advanced a similar amount before it was practical to access the sonic probe hole and take a set of readings. However, at some of the sites where the face was only advanced by 4.0 or 5.0 m (Colliery 'D' area one, site four; area two, site four, and area two, site five. Figures 3.25, 3.31 and 3.32), the stable elevations were already fully developed.

Geometrically speaking, the shape and area of unsupported roof in the drill and blast and continuous miner sections were nearly identical. The drill and blast sections typically have approximate dimensions of 6.0 m across the roadway with 2.5 to 3.5 m of unsupported roof after a blast. The first cut of a continuous miner section varied between 5.0 and 7.0 m in length and 3.0 to 3.5 m in width. The main difference is that the continuous miner initial development shape is perpendicular to that of the drill and blast section.

The only two monitoring sites that indicated obvious increases in the height at which displacement occurred in the roof as further mining occurred, were both in the partial column resin supported roof at colliery 'D' (area two - sites two and three Figures 3.29 and 3.30). Both sites were in intersections that had total relaxations amongst the highest recorded. Their total relaxation values had reached 11 and 5.0 mm respectively prior to the migration of the stable elevation occurring. Both the stable elevations increased quite significantly by approximately 0.5 m and 0.25 m, respectively. Since this occurred well outside the face advance zone of influence at between 56 m and 166 m and 28 m and 158 m respectively, it was time dependent behaviour.

The full displacement with time profile of a variety of elevations up to 2.56 m into the roof at site two, area two, colliery 'D' are presented in Figure 3.44. Between days 11 and 59, the face was advanced from 56 to 166 m. During this period all the strata between the 0.24 and 2.31 m elevations in the roof deflected downwards in unison (upwards on the graph). There was no evidence of any relative displacements occurring within the 0.24 to 2.31 m strata horizon. With time all the roof beams within this region deflected by about 1.0 mm allowing an additional beam above the 2.31 m elevation to become detached and deflect by a similar amount. This upward migration of the stable elevation is evident from the divergence of the 2.31 and 2.56 m anchors in Figure 3.44.

The roof strata at area two, site three, behaved in a similar manner. Two minor differences were observed. Of the approximate 1.0 mm of additional roof deflection measured close to the roof skin, about half was attributed to continued displacement within the bolt horizon. The stable elevation migration released a thinner beam that appeared to lack stiffness and came to rest on the beam below it effectively closing the parting that had existed between them as indicated in Figure 3.30. The laminated sandstone and shale roof strata at this particular colliery with its highly variable bedding thicknesses appeared to be an ideal medium for this stable elevation migration mechanism.

Awareness of this mechanism has important implications as far as roof behaviour monitoring is concerned, particularly with respect to visual indicators such as tell tales. In the suspension support method a weaker layer of roof strata is pinned to a stiffer stronger layer above it. By positioning the top anchor point of a simple tell tale in the stronger layer, preferably above the bolt horizon, the support performance can be monitored and remedial measures taken if it become necessary.

With the beam building roof support mechanism however, the choice of a suitable elevation for the top anchor point is both more complex and critical. Failure to place this anchor point above the final stable elevation of the beam deflection process could result in misleading or potentially dangerous outputs. To quantify a suitable elevation for a particular geotechnical area and support system, a roof behaviour monitoring programme should be initiated to build up a database. In time this information could also be used to assist with computer modelling solutions.

Assuming that the "typical" roof strata was reasonably consistent in all three monitoring areas of colliery 'D', the performance of the different support systems can be compared. The same support pattern was used in all three areas. The least effective support system was the partial resin column based support used in area two. This was in spite of the fact that the roof, being in a continuous miner section, was not subjected to the disturbance associated with the drill and blast mining method, as was the case in area one. There was no real evidence of pre-existing openings in the roof prior to the installation of the support in area two.

In Table 3.1 the average displacement recorded in the intersections in area two compared to the intersections in area one was approximately 80 per cent larger. Even if the intersection with the headboards in area two is excluded, the displacement values are still on average 50 per cent larger. In addition the displacements in the single roadway monitored in area two was three times the average value recorded in the two roadways in area one.

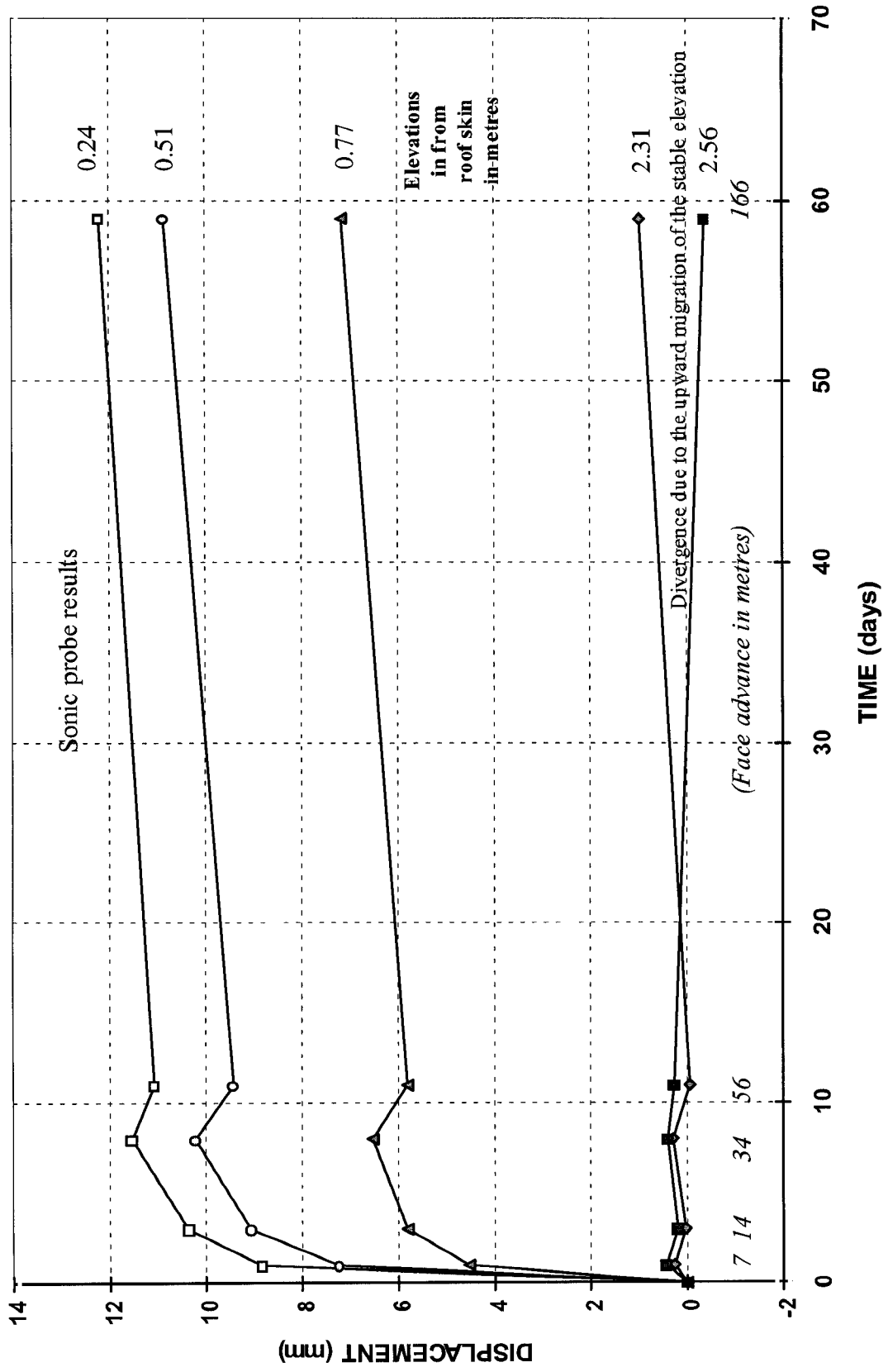

Figure 3.44 Colliery 'D' area 2 site 2 displacements

By averaging the displacements, single curves for the intersections and roadways in each area of colliery 'D' were produced and are presented in Figure 3.45. The support that performed best overall was the full column resin bolts in the continuous miner section (area three). The apparent creep with time exhibited in the area three roadway curve is a function of the averaging process. There is no evidence of creep occurring on an individual basis. The only curve that indicates time dependent creep is the one representing the already discussed intersections in the continuous miner partial resin column supported area two.

Included in Figure 3.45 is the average height of the stable elevation with respect to each curve. The link between the height to which the stable elevation is restricted and the effectiveness of the support in maintaining the integrity of the roof strata within the bolt horizon is apparent in the continuous miner sections. The full column resin support in the drill and blast section however appears to be slightly out of phase with the continuous miner sections. The reasons for this are unclear but could be related to the effects that the pre-existing openings in the roof strata had on the monitoring results. If the area one results were adjusted to include the kickback values, the results would fit the overall trend slightly better. The most significant change is the relative increase in the average total displacement of the intersections relative to the roadways would be reduced to 460 per cent.

The other relationship that is evident from the graph in the continuous miner sections is the increase in the difference between the roadway and intersection results: from 50 per cent in the full column resin supported area three to 150 per cent in the partial column resin supported area two.

The recommended difference between the diameters of the tendon and drill hole in a resin based support system is 6.0 to 8.0 mm. In area three, in an attempt to reduce resin costs, the mine installed 18 mm steel in 22 mm holes which resulted in this difference being 4.0 mm. Even in this highly laminated roof strata, this appeared to work satisfactorily.

Traditionally full column resin is usually used in the worst ground conditions. Here it reinforces the rock mass by bonding the entire length to the steel tendon. This has the added advantage of resisting horizontal displacements within the roof strata which helps to prevent shearing of layers within a laminated roof and limits bending of the strata beams and development of high tensile stresses.

To calculate the volume of resin required for a particular application, the rock engineer uses a relatively simple process. The diameter of the tendon is established according to what load it will be required to carry and is typically 16 mm to 20 mm. The hole diameter is decided on, taking into account the minimum resin thickness and resin to strata surface contact area required and available resin cartridge volumes. Ideally the hole diameter should be 6.0 mm to 8.0 mm larger than the tendon diameter. The idea is to arrive at a combination whereby a set number of resin cartridges will completely fill the void between the tendon and the sides of the hole over a specified distance with the minimum of wastage.

With partial column resin grouting, variations from the desired length are usually not really critical unless it is close to the minimum or critical bond length required or the bonding does not completely fill some critical horizon. However, in the case of the full column resin where the intention is to fill the hole completely, partial filling could result in the degeneration of the overall roof stability. If there is excess resin it will be expelled from the hole during the installation of the tendon. Although this is a useful indicator, as to whether the hole is filled with resin, it is not cost effective. If the actual hole volume is larger than anticipated, there may be insufficient resin to completely fill the hole. In this situation there is no practical way of knowing if the shortage is within tolerable limits.

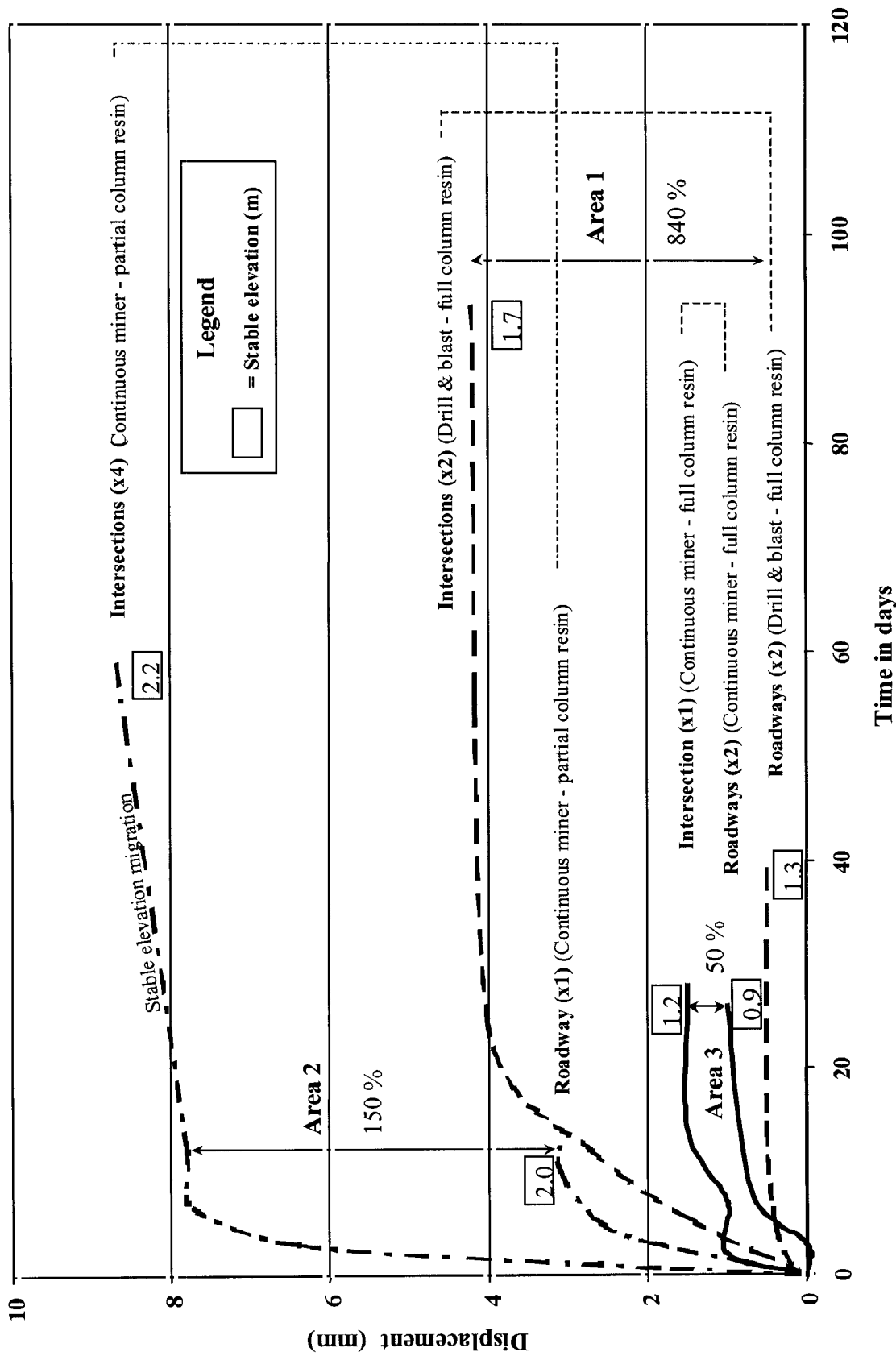

Figure 3.45. Mining method and comparative support performance at colliery 'D'

When calculating the volumes of the various components, the steel bar and resin cartridges are not problematic and can be measured if necessary. The volume of the drill hole on the other hand cannot at present be easily measured and is traditionally calculated on the assumption that a drill bit of known diameter will drill a hole of the same diameter.

This raises questions such as:

How close is this to reality? Does the hole diameter vary along the length of the hole; for example does it increase where softer strata is encountered? How consistent are the volumes of holes drilled to the same depth in the same strata conditions?

Due to the financial implications of using the minimum quantity of resin, the current trend is to use the smallest hole diameter that is practical without affecting the performance of the resin bond. The smaller the hole diameter, the more dramatic the effect of any variations in the diameter becomes.

The effect that an average increase in hole diameter from 22 mm to 23 mm has, on the percentage increase in the cross sectional area of both the hole and the resin required to fill the void between the bolt and the hole, has been calculated for a 16 mm tendon and the results plotted in Figure 3.46.

Ideally a 1.8 m bolt length should be installed in a hole approximately 1.76 m in depth, allowing the additional 40 mm to protrude from the hole to accommodate the washer and nut. By using a total "full column" bond length of 1.75 m in a 22 mm average diameter hole containing a 16 mm bolt, the resin volume required was calculated. Using this fixed volume as the datum and the percentage increase in the required cross sectional area of resin relative to the hole diameter increase (as indicated in Figure 3.46), the decreasing bond length relative to the increasing hole diameter is plotted in Figure 3.47.

An increase in average hole diameter from 22 mm to 22.1 mm would result in a bond length decrease of 33 mm. Although it is difficult to decide exactly what constitutes an acceptable decrease with regard to bond length in poor roof conditions, a 0.3 mm increase in the average hole diameter to 22.3 mm results in a bond length decrease of close on 100 mm. These values could significantly affect the operation of a full column resin based support system as the loss of resin is usually at the worst position, close to the roof skin. Furthermore, in the case of resin end anchored tendons, if the volume of resin used was close to the critical bond length and no allowance was made for oversize, drilling installations could be made where less than the critical bond length was achieved. This could result in lower than expected support resistance, again compromising roof stability and safety.

A similar detrimental effect can be caused by overdrilling the required hole length. Using the typical 22 mm drillbit/hole diameter and a 16 mm tendon as an example, the reduction in bond length is approximately twice the overdrilled length.

Consideration therefore needs to be given to incorporating a safety factor into the calculation of resin requirements, based on Figures 3.46 and 3.47.

In order to prevent massive roof falls, it is imperative that the support type and pattern installed is capable of limiting the displacements within the bolt horizon. By creating a stiff beam, the chances of preventing upward migration of the stable elevation and subsequent unravelling of the roof strata are reduced.

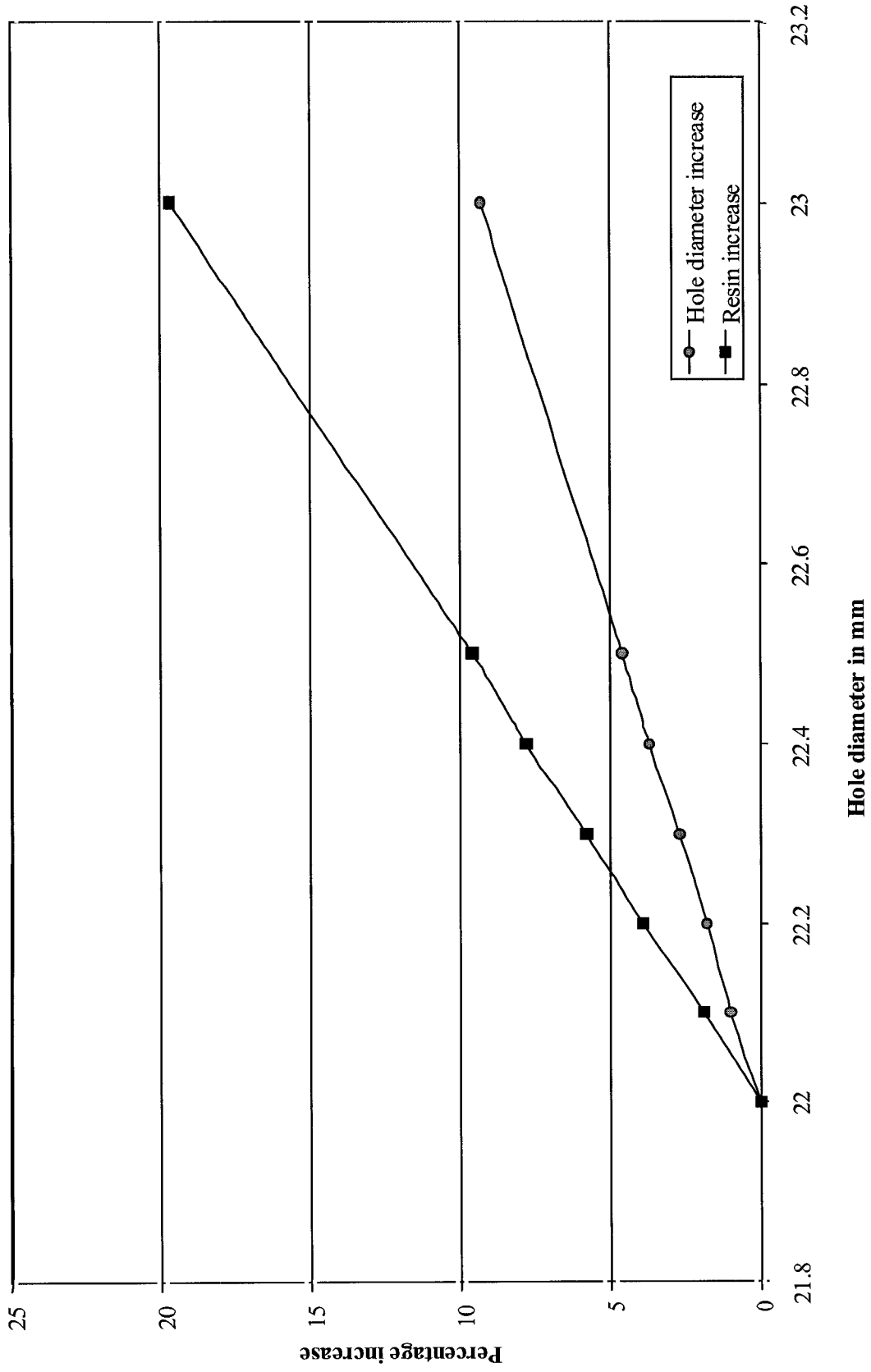

Figure 3.46 Effects of hole diameter increase on the cross sectional area of the hole and resin requirements using a 16 mm bolt and 22 mm drill bit

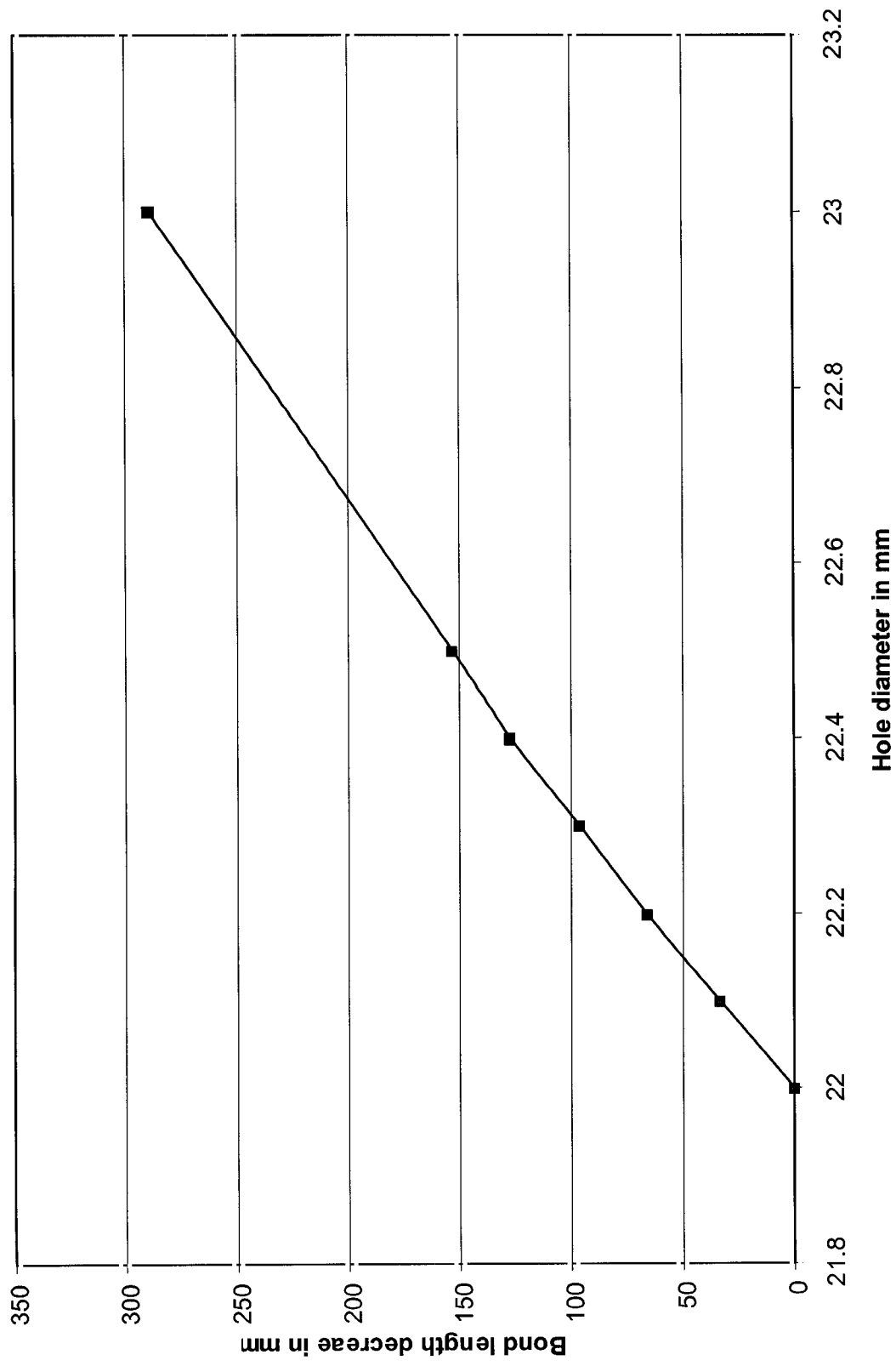

Figure 3.47 Effects of hole diameter on resin bond length using a 16 mm bolt and a 22 mm drill bit

3.9.3 Analysis of results of field measurements using numerical and analytical methods

The deformations obtained from underground field measurements were compared to simulations from numerical models and to results from analytical methods. The work reported here is of a preliminary nature and was carried out mainly to obtain insight into the capabilities of routine type modelling. In the analysis of the analytical method the following equation and elastic properties were used;

$$\text{Maximum deflection} = \frac{qgL^4}{32Et^2} \quad (\text{mm}) \quad (3.1)$$

where L = roof span (width of roadway)
 t = thickness of roof layer
 q = density of suspended strata (sandstone=2500, shale=2500, coal=1600 kg/m³)
 g = gravitational acceleration
 E = Young's Modulus (sandstone=10 GPa, shale=8 GPa, coal=3500 GPa)

Results from underground field trials were obtained from areas where both suspension and beam building support methods were used. For a proper comparison, in the analysis of results using the analytical method, the road width is taken as the roof span for both suspension and beam building mechanisms. The thickness of the roof layer is taken as the bolt length or the immediate roof layer thickness, for beam building and suspension mechanisms respectively.

In order to obtain accurate results, intersections and roadways were analysed separately (intersection is taken as 40 per cent wider than the roadways). Blasting damage of 0.3 m into the side of each pillar (Wagner and Madden, 1984) is taken into account in both the analytical calculations and the numerical modelling, where the drill-and-blast method was used.

The comparison of results for both roadways and intersections obtained from the analytical method and in situ monitoring are given in Figure 3.48. In collieries "B" and "C" the analytical solution over estimated the actual deflection, generally by substantial margins, whilst in the other collieries the measured deflection was considerably larger than that calculated. As can be seen from this figure, while the analytical method gave a better prediction in the roadways, none of the results could be predicted using the approximate analytical method in the intersections. However, the results obtained from in situ monitoring take the effect of roofbolting into account, this was not the case in the analytical calculation. Nevertheless the discrepancies between the in situ and analytical results indicate significant inelastic behaviour.

A 2 dimensional (2D) finite element numerical modelling code Phase2 was used in the analysis of the in situ monitoring results. Elastic properties of the strata were taken as those used in the analytical solutions.

The numerical modelling results showed much less variation than the analytical solutions and in 60 per cent of the cases provided results which better matched the in situ results.

The comparison of results obtained from in situ monitoring and numerical modelling is illustrated in Figure 3.49. This figure also showed that there is a wide scatter between the results obtained from in situ and numerical modelling for both roadways and intersections.

These variations in both analytical and numerical methods are due to many parameters which can effect the results obtained from both analytical and numerical calculations.

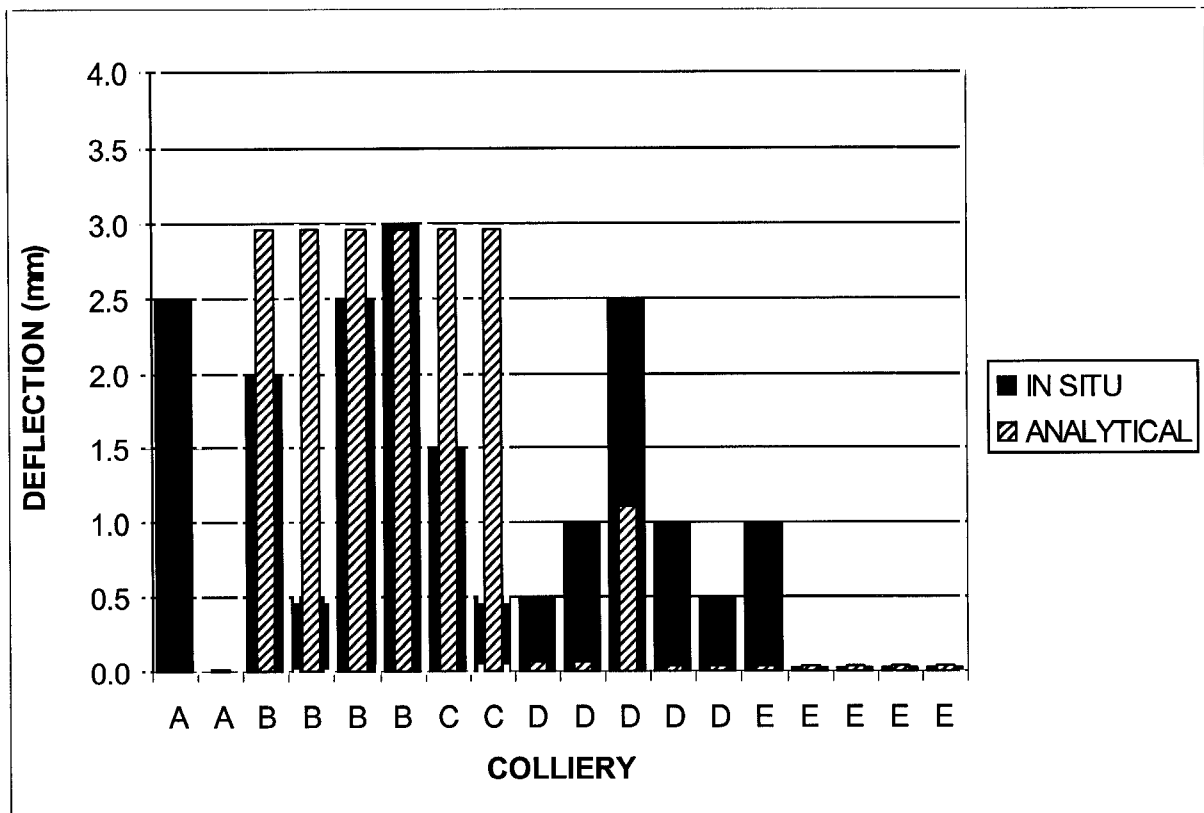

a) Roadways

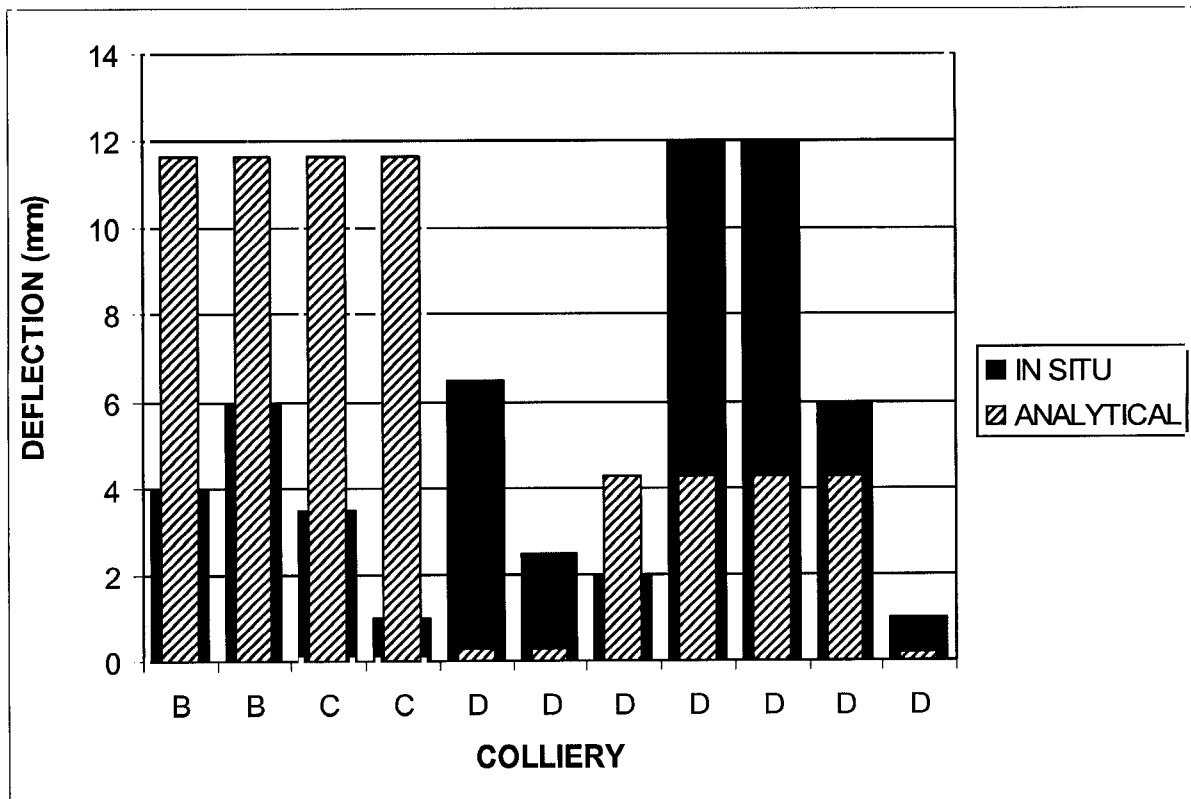

b) Intersections

Figure 3.48. Comparison of results obtained underground field trials and analytical method

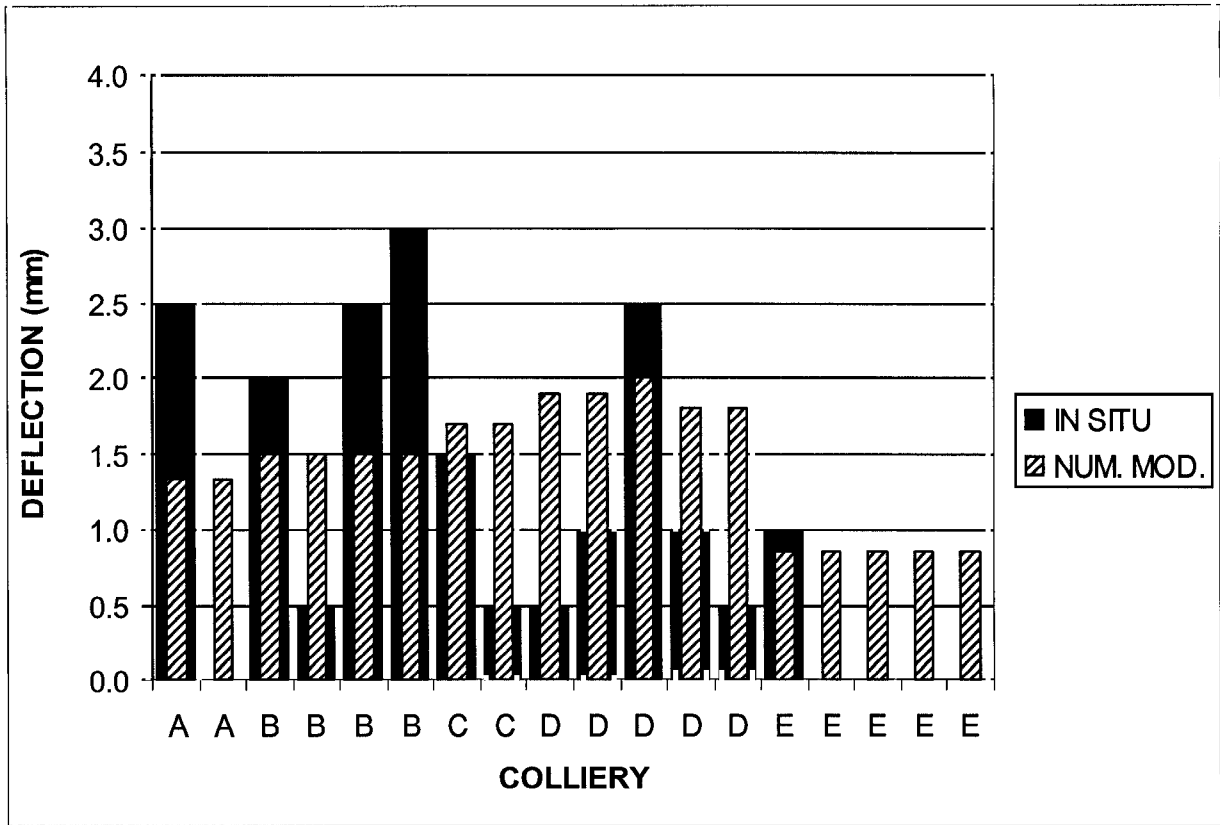

a) Roadways

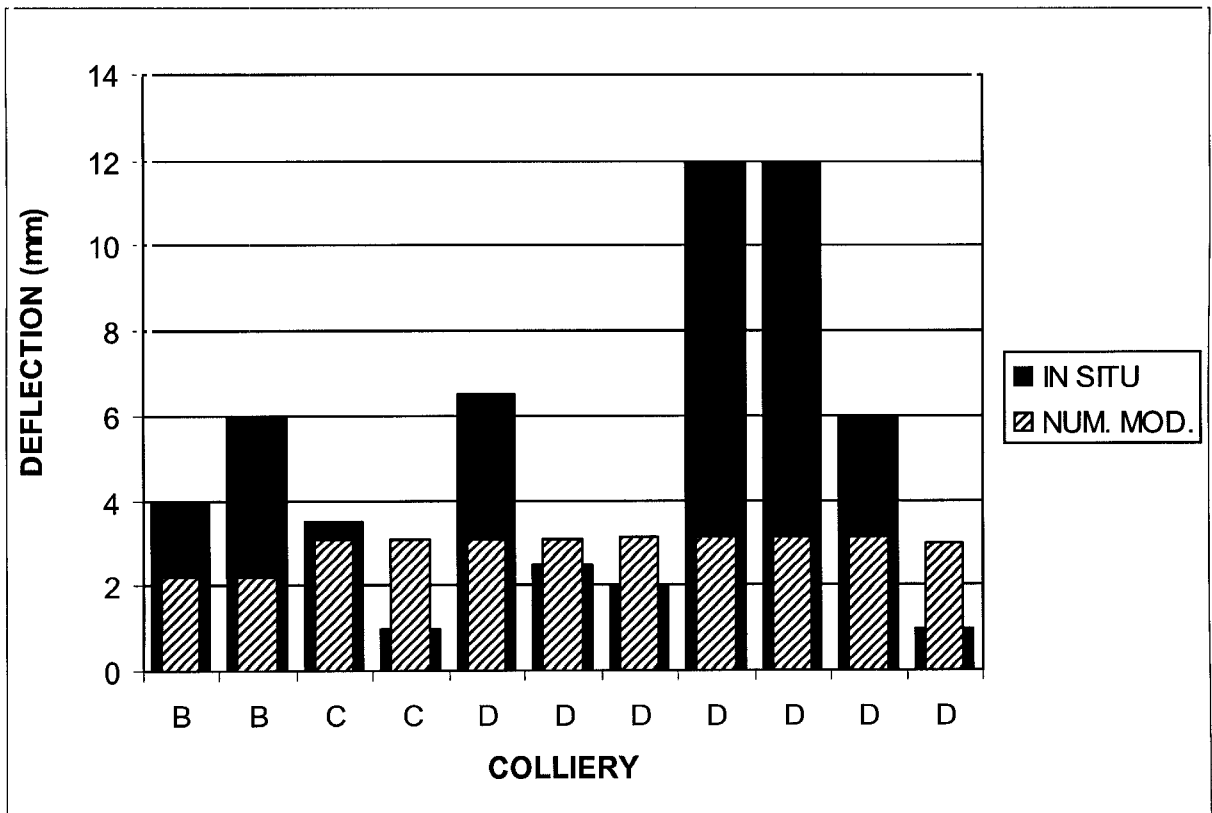

b) Intersections

Figure 3.49. Comparison of results obtained underground field trials and numerical modelling

These parameters are listed below;

- i) Elastic properties of strata (Young's modulus and Poisson's ratio)
- ii) Friction and coefficient between the bedding planes
- iii) Actual unit weight of strata
- iv) Number of pillars in a panel
- v) Major horizontal stresses
- vi) Effectiveness of roofbolts used underground
- vii) Loading of strata in the roof, and
- viii) Discontinuities in the immediate roof

The effect of many of the above mentioned parameters are unknown and are not incorporated in the current design methodology. These parameters were not included in the numerical modelling analysis. These parameters need to be investigated and their effects need to be established. The limitations of 2D modelling in this 3D environment also probably contribute to the relatively poor correlation between the in situ and modelling results. The benefits of 3D modelling need to be determined.

3.10 Roadway widening

A site was located at Colliery A where a section of roadway was widened from 5.1 m to approximately 12 m. The generous co-operation from the manager and underground personnel in carrying out this experiment is gratefully acknowledged

As previously mentioned some areas of this colliery have a high horizontal stress regime. Damage, in the form of guttering, appears to be random in nature. In the area selected for the roadway widening experiment, there was no guttering or any other obvious evidence of high horizontal stress. Based on years of local experience, the rock mechanics and underground personnel were of the opinion that there was no high horizontal stress present at the roadway widening site.

The proposed site was an existing cubby used as a waiting place. The cubby and adjoining roadways were carefully examined. No significant geological features were observed that could adversely effect the roof stability in the immediate area. The roof was supported using 20 mm diameter 1.8 m long full column resin bolts, four bolts in a row with the rows 2.0 m apart. The mining operation was carried out by continuous miner.

3.10.1 Instrumentation

The cubby was 5.1 m wide and 8.0 m long. Two sets of instrumentation were installed in the roof approximately 1.0 m from the face. Each set consisted of a 7.3 m deep sonic probe extensometer and three fixed levelling points anchored at 2.7 m, 1.8 m and close to the roof skin. Two tell tales were also installed at each position to monitor the strata between the roof skin and the 1.8 m and 2.7 m elevations. The instrumentation layout is shown in Figure 3.50. One set of instrumentation was positioned on the centreline of the 5.1 m wide original excavation. The other approximately 1.0 m from the right hand sidewall so that it would in time be closer to the final centreline of the widened roadway. Prior to the start of the experiment, the final roadway width was unknown. The roof and sidewall conditions could only be assessed during the widening operation and a decision taken when to stop.

The purpose of the sonic probe installations was to gather detailed information of the roof behaviour as the cubby face was advanced and the roadway formed (in a similar manner to the other 29 sites investigated). It was also anticipated that some additional readings would be taken as the roadway widening commenced and for as long as it was safe to enter the area if temporary support was installed. However, both sonic probe installations were damaged and were abandoned after the initial roadway was formed and the face advanced away from the site.

When the face was advanced, very small displacements were recorded close to the roof skin at both the sonic probe hole locations. The total value at the side hole was 1.0 mm while 2.0 mm was recorded at the centreline hole. These results are typical of the deflection of a roof beam.

The fixed levelling points were installed primarily to be able to continue to monitor the roof remotely, during and after the roadway widening operation. To accomplish this requirement permanent levelling staves were attached to the individual fixed points protruding from the holes in the roof, immediately prior to the first widening cut with the continuous miner. These staves remained in position for the duration of the monitoring period.

From funds supplied by the CSIR, a tell tale capable of giving a visual indication of the degree of differential displacement within a section of the roof strata has been developed. Although this device worked well in the laboratory environment, it had not been tested underground. The roadway widening site provided an opportunity to assess the in situ performance of these tell tales by comparing their output against the survey levelling results. Four tell tales were installed to monitor the same sections of roof as the fixed levelling points.

A month after the initial installation, when the time came to fit the permanent levelling staves, one of the fixed levelling points and most of the tell tales were found to have been damaged. This appeared to have been as a result of the tramming of loaded shuttle cars through the site which had a relatively low mining height of approximately 2.1 m. As a result, both the 2.7 m levelling point and telltale at the original roadway centreline site were irreparably damaged and were abandoned.

3.10.2 Widening procedure

The outline and dimensions of the original cubby, as well as those of the subsequent development in the immediate area, are indicated in Figure 3.51. Included are the positions of the two sets of instrumentation.

The roadway was widened in three stages as illustrated in Figure 3.52. Because of the element of risk involved, the first two cuts were stopped slightly short of breaking through into the roadway perpendicular to the one being widened. The intention was to use the behaviour of the slender pillar formed to assist in assessing the overall general stability of the area as widening of the roadway continued. Cut three was positioned to try and get the sidewall as close as possible parallel to the centreline of the roadway. Based on the lack of load induced spalling on the slender pillar the third cut was extended until it just broke through into the roadway. This reduced the slender pillar, to becoming a snook estimated to be 0.8 to 0.9 m wide and 3.0 m long. Although it did not appear to be carrying any excessive load at the time, the risk involved in removing it was considered too high and it was left intact.

During the widening process no additional roof support was installed. At the 12 m final width, only the initial 40 per cent of the span had been supported with roof bolts.

Taking the surrounding pillars as the boundaries, the span of the final excavation was 12 m x 25 m. Even if the snook is considered as being an effective support system and boundary, the minimum dimensions are reduced to 12 m x 19 m. The monitoring was limited to the supported 40 per cent of the final roadway width. The opposite side of the widened roadway was unsupported and in all probability would have experienced larger differential displacements. Nevertheless the roof remained intact without even any minor falls being noted.

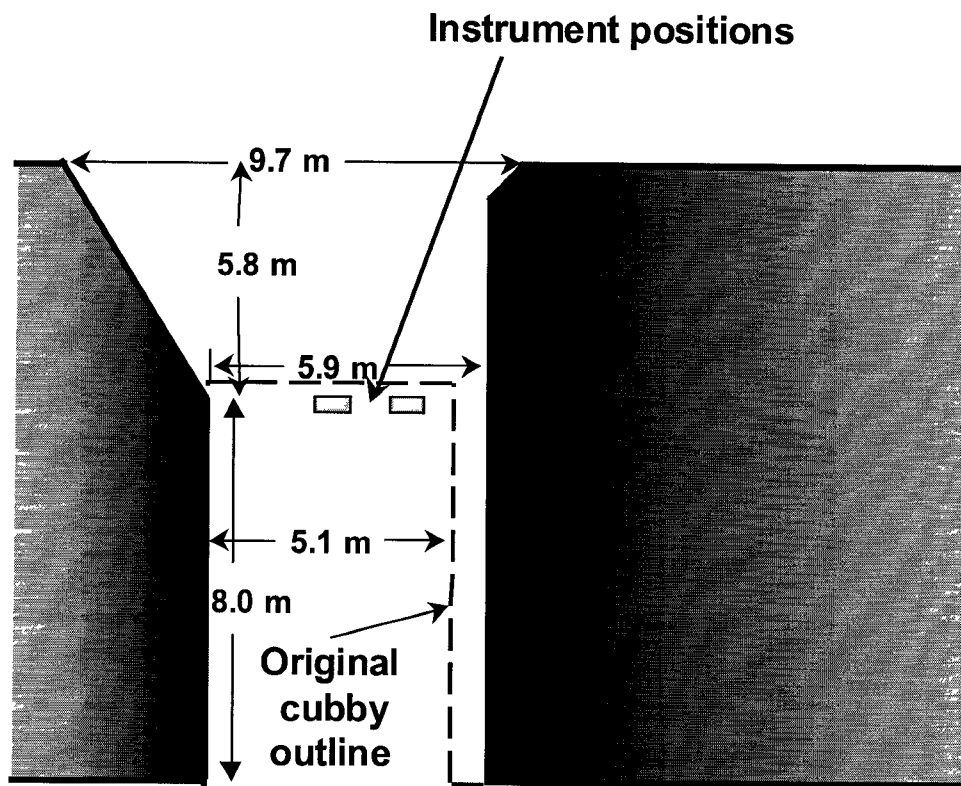

Figure 3.51 Roadway and adjacent intersections prior to widening

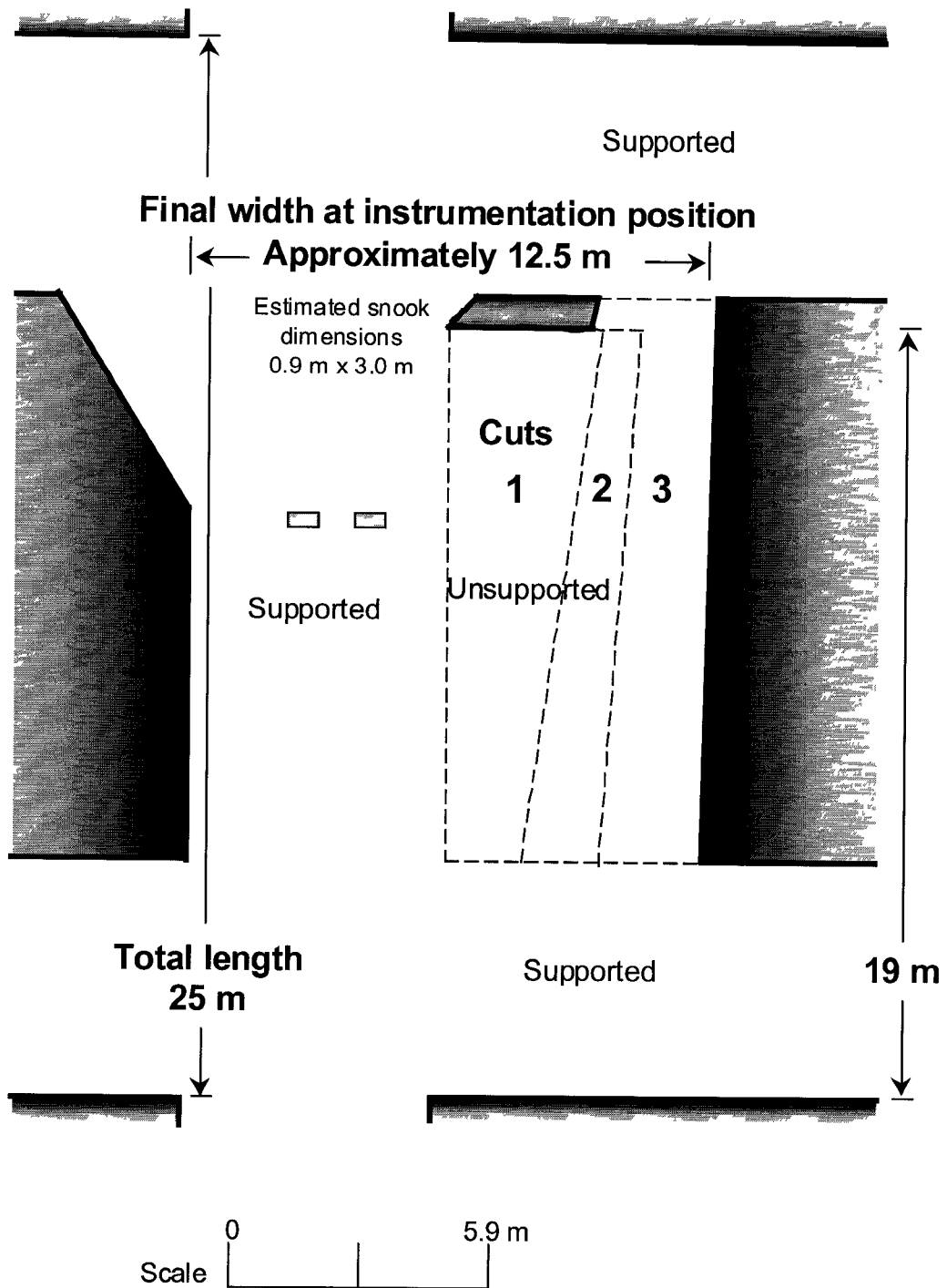

Figure 3.52. Cutting sequence and final roadway shape

3.10.3 Results

The monitoring of the roof deflection has been divided into two sections. The initial one is the short term dynamic performance during the widening process and the other, the longer term behaviour of the 12 m wide roadway with time. With the exception of Figure 3.56 the roof deflection and differential displacements have been given negative values. This produces profiles of similar shape to the roof sags experienced underground.

The roof deflection recorded during the widening phase is presented in Figure 3.53. On the horizontal scale the left hand sidewall is fixed at zero, while the position of the right hand sidewall is indicated for each set of readings taken. The position of the five levelling points are also plotted relative to the left hand sidewall. In this dynamic situation it was difficult to determine if any differential displacements, such as bed separation, were occurring. The change in shape and increase in displacement values towards the mobile centreline of the roadway occurred in the anticipated sequence in all three deflection profiles. Although not conclusive, this suggests that during this period the 2.7 m thick roof beam being monitored remained intact.

Figure 3.54 covers the time period from day one, when the first set of readings were taken on the 12 m road width, up until the final reading on day 38. The horizontal axis indicates the position of the measuring stations relative to the left hand static sidewall. In this graph two different mechanisms can be seen. The 2.7 m levelling point, being the deepest in the roof, traditionally gives the best indication of the overall roof deflection and is the least likely to be influenced by the unravelling effects of delamination which usually starts close to the roof skin. The deflection of this point can be seen to increase with time. The change in shape of the five point levelling profile indicates that differential displacements were also occurring in the roof beam during this time period. These can be seen more clearly in Figure 3.55.

Here the relative displacement of both the 1.8 m and skin anchor points were plotted using the 2.7 m levelling point as a static reference. The separation between the skin and 1.8 m elevation on the right hand side had started within 14 hours of the roadway reaching the 12 m width. The same comparison at the centreline showed no evidence of differential displacement at this time. This could either be as a result of an opening, once initiated, migrating towards the edge of the roadway or that the displacements were localized and not interconnected. By day nine the displacements at both instrumentation positions were well defined and tended to stabilize from day 24 onwards. The maximum differential displacements values recorded were 1.0 mm at the right hand position and 2.0 mm at the centreline. The fact that the greater value occurred closer to the sidewall suggests that these displacements may have been more localized than continuous across the roof beam.

A point worth noting, which is apparent in Figures 3.53, 3.54 and 3.55, is the behaviour of the 1.8 m centreline levelling point. It appears to have undergone less overall displacement than the 2.7 m point which is anchored higher in the roof strata. This is a true reflection of the situation. The explanation being that, as a result of the widening of the roadway, the 2.7 m point ended up closer to the centreline of the widened roadway. The roof deflection over the larger span influenced the 2.7 m point to a higher degree than the 1.8 m point closer to the sidewall. This was also the case with the skin anchor situated even closer to the sidewall, up until day two, when it also still recorded less deflection than the 2.7 m point.

The last graph, presented in Figure 3.56, shows the behaviour of all five points with time. After starting with relatively rapid displacement, as a result of the roadway widening process, up until day two, they continued at a fairly constant rate until day 24. From that point until when the final readings were taken on day 38, the velocity dropped 75 per cent on average.

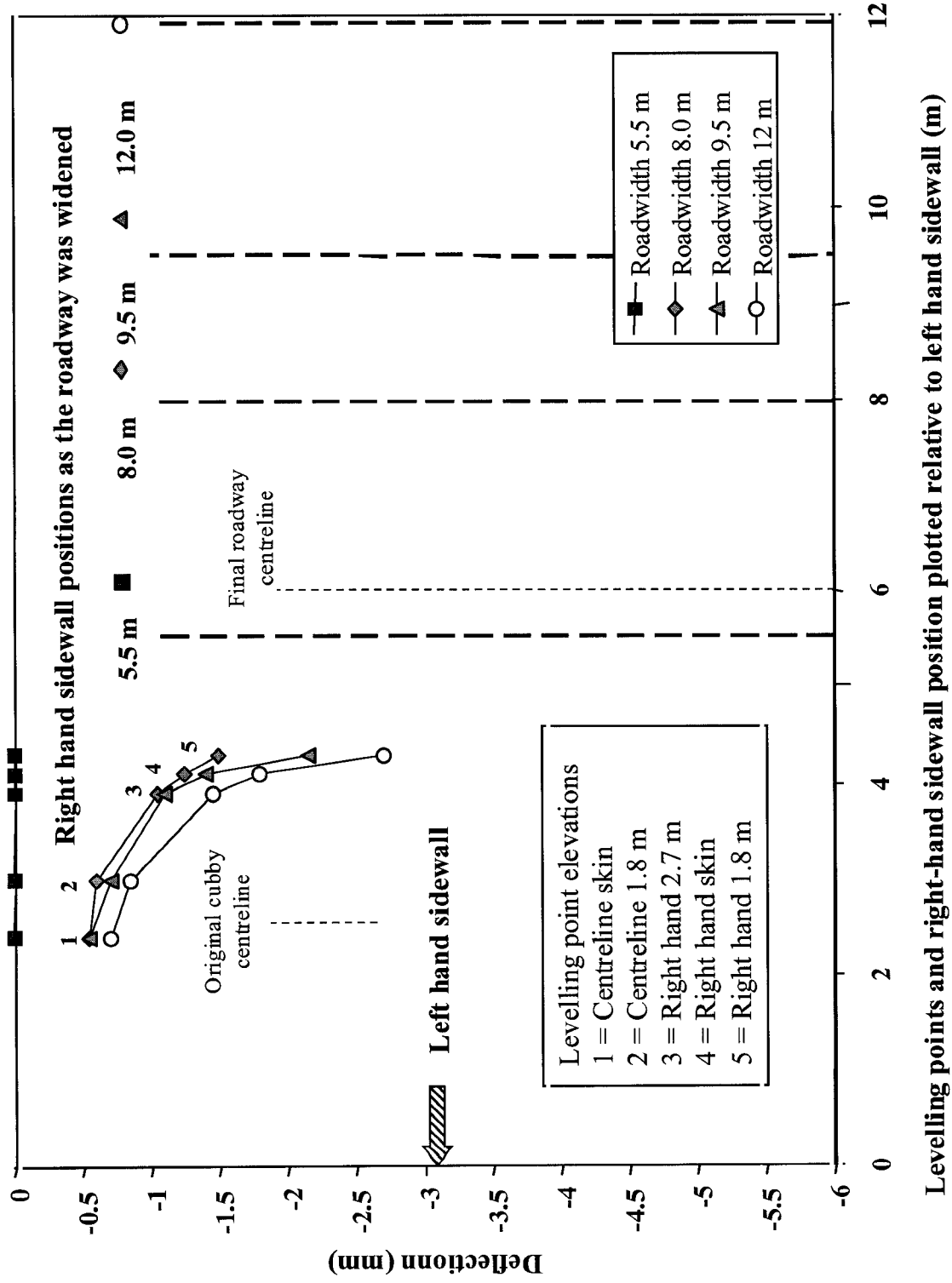

Figure 3.53. Increase in roof deflection with widening of roadway

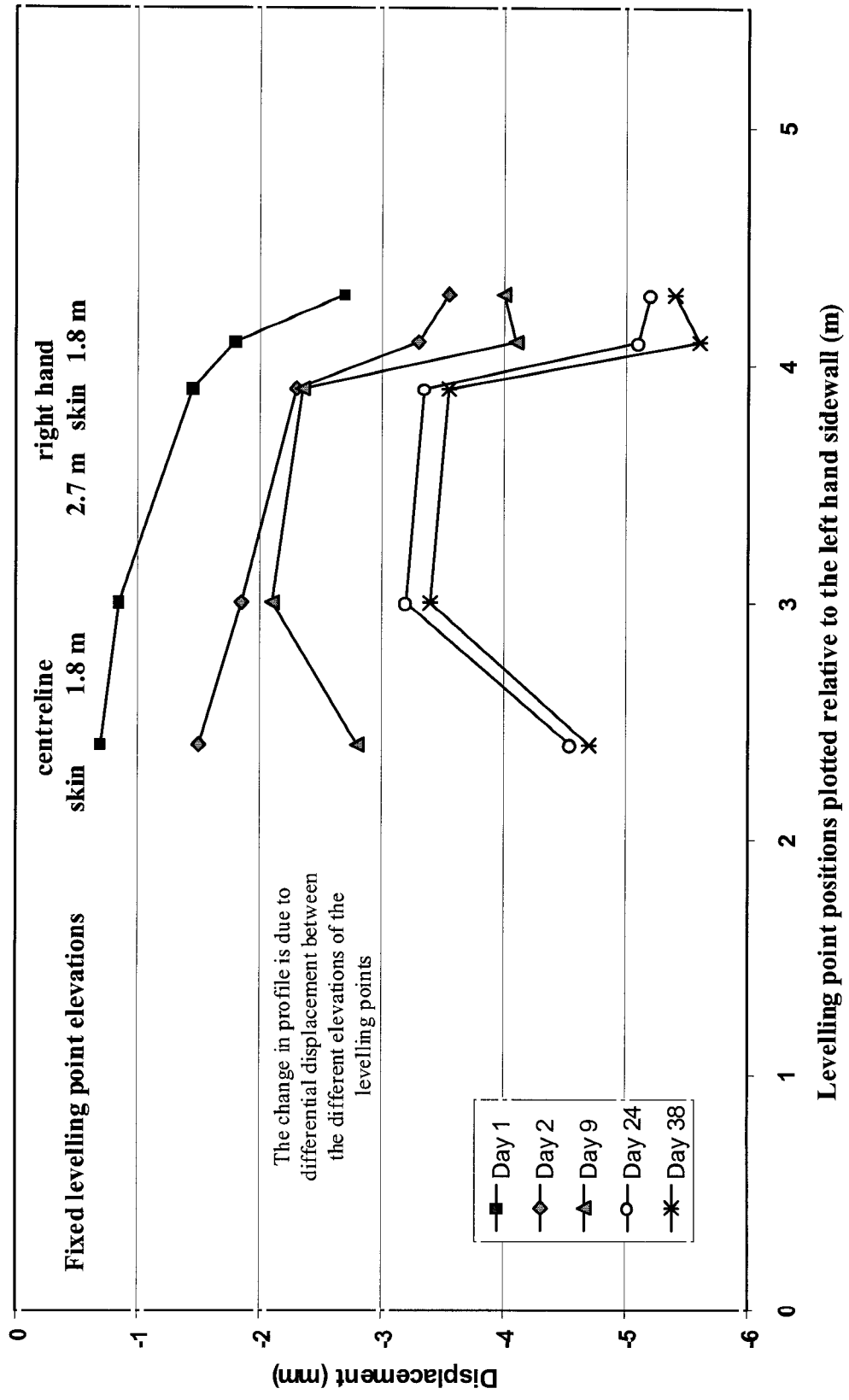

Figure 3.54. Roof behaviour of the 12 m widened roadway with time

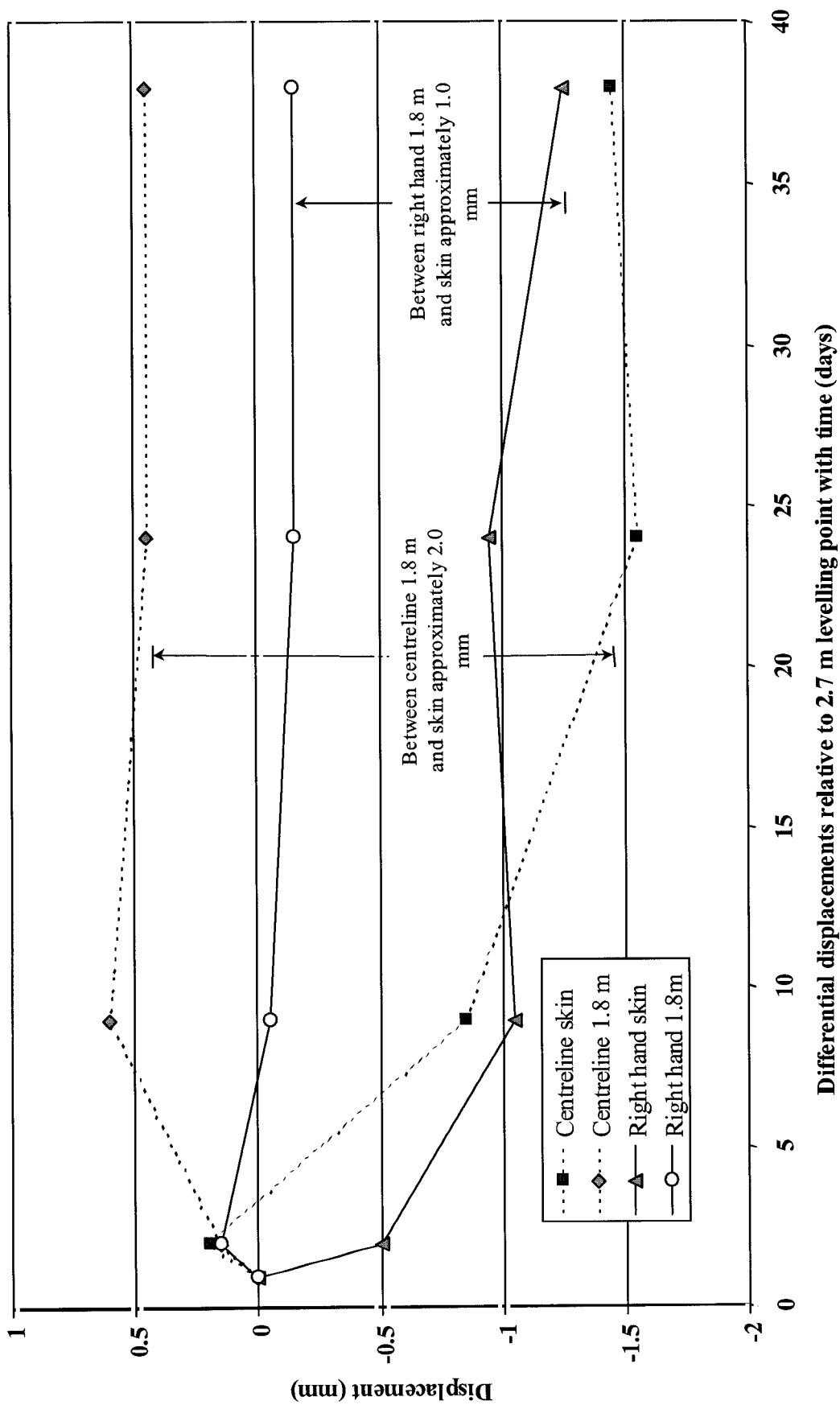

Figure 3.55. Separation within the roof beam with time

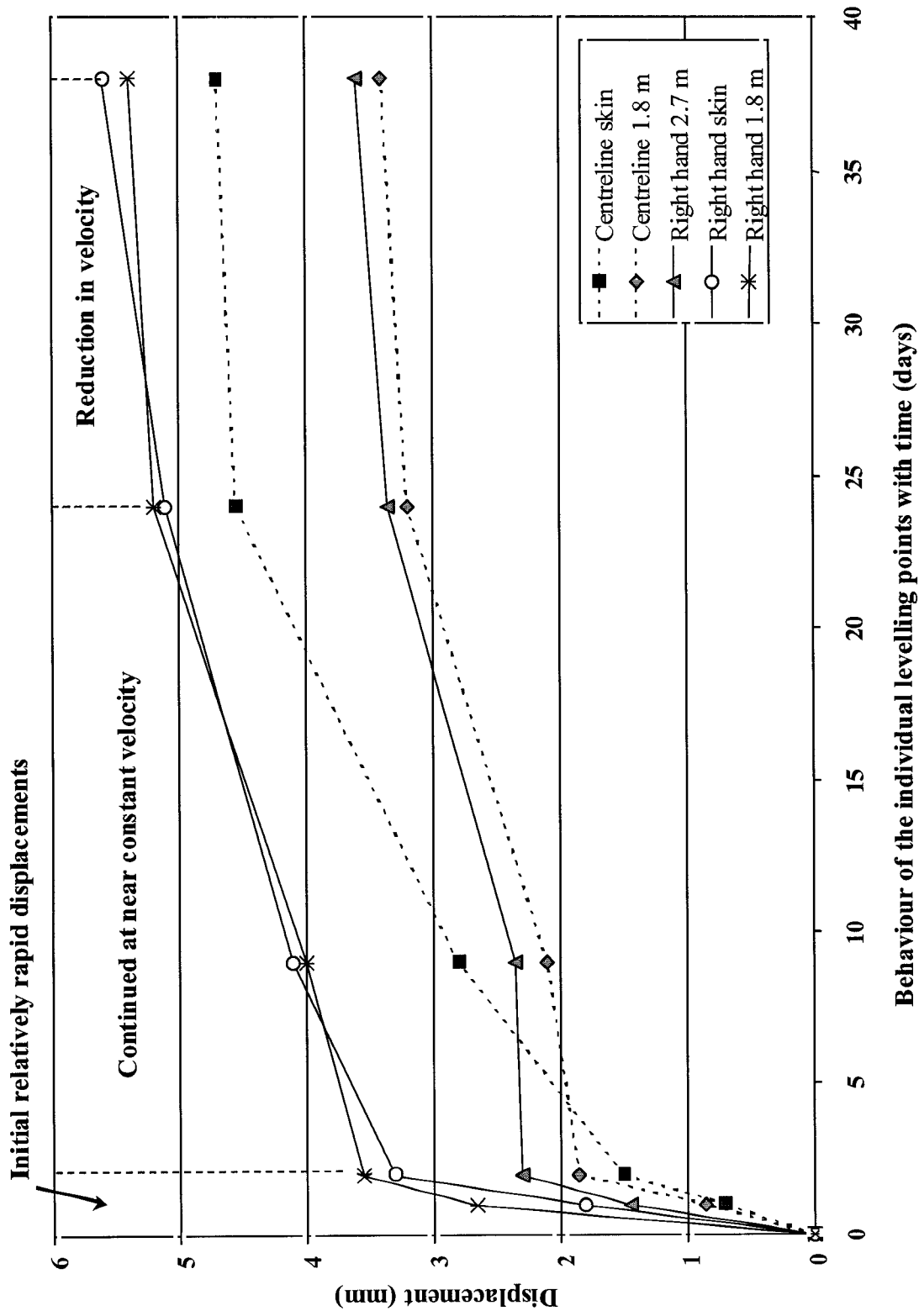

Figure 3.56. Displacement rates as a function of time

The photograph shown in Figure 3.57 was taken on day nine. The general stability of the area is evident from the intact corners of the snook and the clean cut edges of the break through hole to the right of it. The five permanent levelling staves and the three tell tales can be seen in the original supported roadway on the left hand side. The lack of definition on the staves and tell tales is due to the use of reflective tape as a covering material. With the normal light intensity of a cap lamp they are clearly visible from a distance. However, the reflection of the high powered camera flash over exposes them on the film.

Because of the distance involved, the tell tales were observed using the telescope in the survey level. Estimates of the indicated displacements were made relative to a 5.0 mm graduated scale on each tell tale. These were then compared to the appropriate levelling results once they had been calculated. Even though the differential levelling results were very small, the largest being 2.0 mm, they were evident and the estimated values were close to the values derived from the levelling.

The last visit was made to the site on day 52 as the area was about to be sealed off. Unfortunately all five permanent staves were missing so it was not possible to get a final set of measurements. The tell tales were however still in position and there was no evidence of any even minor roof falls in the area. The snook was intact and appeared to have changed very little, if at all since the photograph shown in Figure 3.57 was taken on day nine.

From the tell tale observations, the differential displacements between the two roof skin and the 1.8 m elevation had not changed and was much the same as it had been since day 24.

3.10.4 Conclusions

The stability of the excavation confirmed that the original assessment of the area was correct. The roof would not have survived intact if there were any significant horizontal stress or geological features in the immediate area. Roof collapses were observed one pillar away as a result of slips.

This appears to have been a classic case of gravitational loading and highlights the variations that can occur in a single mining area. Other sections of the mine exhibited guttering and horizontal stress driven roof failures in supported roadways as narrow as 5.0 m.

The fact that the personnel intimately involved in the underground conditions at this particular colliery were able to identify this area as being unlikely to be influenced by high horizontal stress is significant. The signs they use to assess the presence of relatively high horizontal stress levels were absent in this particular area.

In South Africa from stress measurement data collected in civil engineering tunnels, as part of SIMRAC project GAP511b, the average k-ratio was 1.97. From this data, compiled from depths of between 30 and 200 m below surface, the k-ratio varied between 0.6 and 4.9. There was no recognizable relationship between the depth and the k-ratio with a wide spread in the values as indicated in Figure 3.58.

The horizontal stress driven buckling, or shearing effect, compounds the displacements induced into the roof strata by a purely gravitational loading system. This is well documented in some Australian collieries where it is sometimes particularly severe with roof skin displacements of hundreds of millimetres being initiated as high as 5.0 m into the roof. In South Africa the cause and effects are far less dramatic as a result of which they are often not recognised as being present or taken into account in the support design procedure.

During the monitoring period no roof falls occurred at any of the 29 sites, even where 12 mm displacements were measured. As a result it was not possible to try and establish critical roof displacement values for any of the geological regions.



Figure 3.57. Experiment site taken on day nine

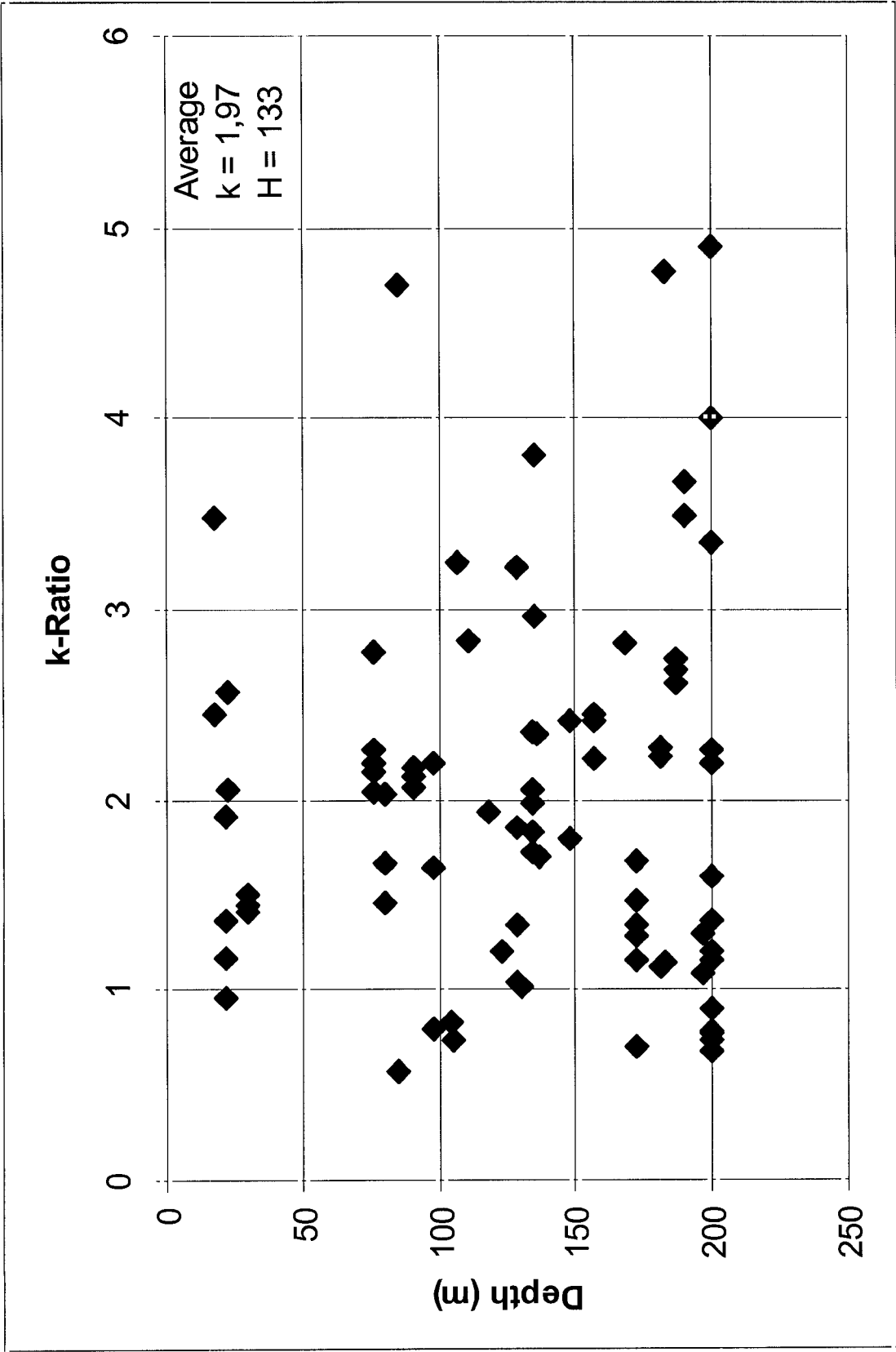

Figure 3.58. k-ratio at various depths in civil engineering tunnels

The only South African group other than Miningtek known to be actively monitoring roof behaviour using the sonic probe is Amcoal. At a site, at one particular colliery, Amcoal measured a maximum of 5.0 mm of roof skin displacement. When the site was revisited so that another set of readings could be taken, a roof fall had occurred. This incident suggested to them that the critical roof skin displacement in this particular area was of the order of 5.0 mm. This finding highlights the site specific and geology dependant failure of roof.

Another interesting phenomenon that the Amcoal monitoring recorded was the effect of additional support in the form of cable anchors, the results of which are presented in Figure 3.59. At a strategically important site, the roof had remained stable for three months. During the next three and a half months (days 89 to 202), a slab of approximately 1.0 m thick became detached from the strata above it and deflected by 3.0 mm. Differential displacements within the slab were about 1.0 mm. The combination of these two mechanisms displaced the roof skin by approximately 4.0 mm. This site was not at the same colliery where the roof fall in the monitoring area had been recorded. Nevertheless, because of the critical position of the site and the fact that the displacements were approaching 5.0 mm, on day 202 the decision was taken to install additional support in the form of 20 ton cable anchors.

On day 208 a set of sonic probe readings were taken after approximately half the cable anchors had been installed. The tensioning of these cables had lifted the slab by approximately 1.5 mm partially closing the parting just above the 1.0 m elevation. When the site was revisited two months later on day 279, some time after the completion of the cable anchor installations, the parting had closed completely and there appeared to be some minor reversal of the differential displacements within the slab itself.

The monitoring results, presented in Figure 3.59, have been separated to better display the mechanisms involved. The upper section illustrates the detachment of the roof slab with time up until day 202. The bottom section, starting on day 202, shows the tensioning of the cable anchors lifting the loosened roof slab back up to its near original position.

The net result of the cable anchor installation was to lift the detached slab back to more or less the same position that it was monitored at between days 89 and 119 when the total displacement was of the order of 1.0 mm. By reducing the bending within the slab or beam, the induced tensile stress in the immediate 0.5 m of roof strata underwent a corresponding reduction thereby increasing the immediate roof stability.

3.11 Strain gauged roof bolt experiment

In 1992, with Chamber of Mines Research Organization (COMRO) funding, preliminary trials were conducted using strain gauged roof bolts with the intention of monitoring the roof bolt performance. Since the results have never been published, it is considered appropriate to include them as part of this report.

At the time, the main aim of the experiment was to measure the initial load distribution in the bolts and compare them with numerical modelling results using FLAC. The load profile of a full column resin end anchored pretensioned bolt was unknown. The second aim was to monitor any increases in load with face advance and time.

The experiment was conducted at Colliery M at a depth below surface of approximately 320 m. The section was mined on pillars with 36 m centres and 6.0 m wide roadways. The roof was interlaminated mudstone and shale and a number of intersections had collapsed. From observation holes drilled into the roof in some of the intersections, there was evidence of horizontal shear displacements at between 0.8 and 1.5 m into the roof. This was observed as dislocation within the vertical holes of approximately 10 to 15 mm.

Detachment of roof slab with time

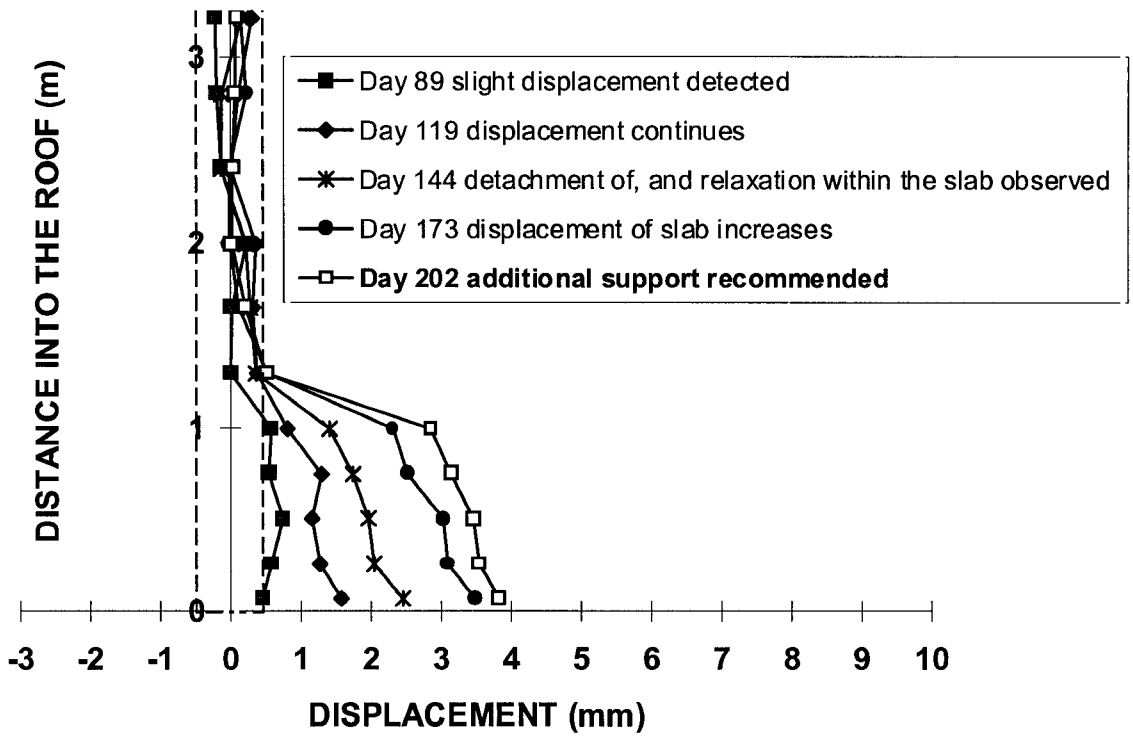

Uplift of roof slab by cable anchors

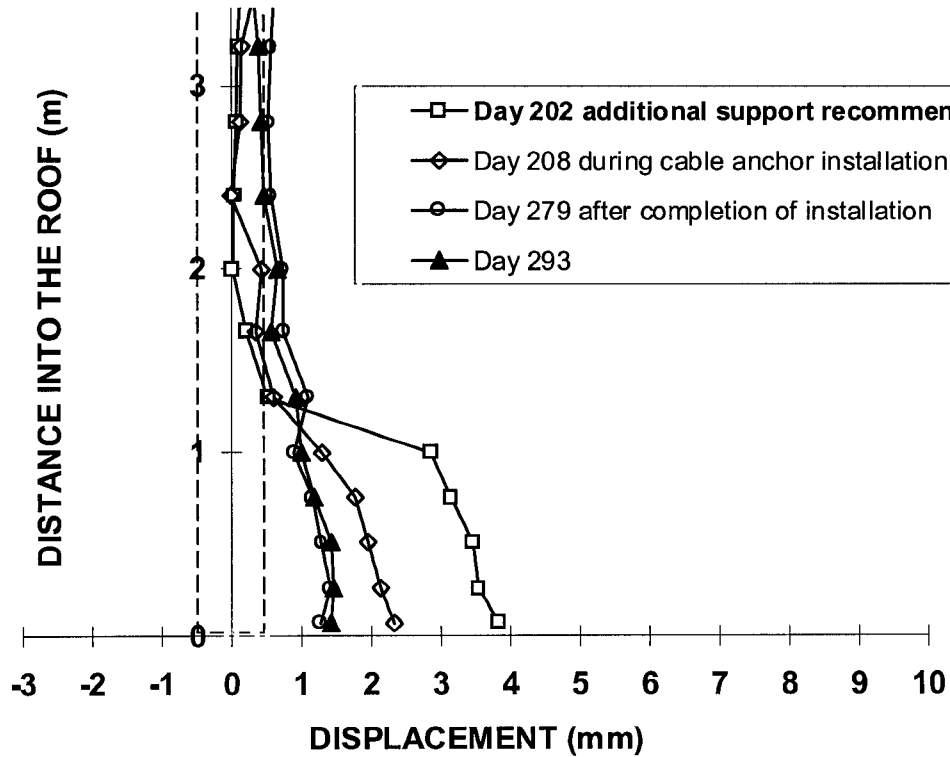

Figure 3.59. Remedial effect of additional active support (cable anchors)

The roof support consisted of 20 mm diameter full column resin bolts, 2.4 m long in alternating rows of three and four bolts. In the four bolt rows the bolts were installed at 0.75 and 1.0 m from each sidewall. The three bolt rows had a centreline bolt with the other two 1.5 m from each sidewall. The rows were 1.5 m apart. As a result of the collapses, additional support in the form of cable anchors was installed in the intersections. The roof bolt holes were 28 mm in diameter. A 450 mm long 25 mm diameter capsule of 30 second resin was used at the top of the hole to enable the remainder of the bolt length to be tensioned with the roof bolter prior to setting of the slower 120 second resin.

In conjunction with the measuring of the strain gauge values, additional instrumentation was installed alongside the bolts to monitor the roof behaviour. These consisted of fixed survey levelling points situated at 3.0 m, 1.5 m and at the roof skin. A sonic probe extensometer hole drilled to a depth of 3.5 m had a total of nine anchors installed in it. Although the roof falls were predominantly in the intersections, these preliminary tests were carried out in a roadway. The intention was to install the bolts close to the face with one in the centre and the other 1.0 m from the sidewall.

The bolts were modified by a local strain gauge based load measuring specialist. Each bolt had 10 strain gauges attached to it. These were fitted at 0.21 m intervals into a single slot 6.0 mm wide and 6.0 mm deep, machined along the side of the bolt, 0.2 m from the top end of the bolt up to the beginning of the threads. A 5.0 mm diameter hole was drilled along the axis of the bolt through the threaded section to intersect the slot and act as a conduit for the wires which terminated at a plug socket rigidly attached to the end of the bolt. This socket was used to connect the strain gauges to the readout unit.

Prior to the final assembly of the bolts, a dummy bolt with a slot cut in it was used to test the effectiveness of a variety of epoxy fillings and coverings to protect the strain gauges and wiring. A spinning adapter was designed to protect the plug socket during the installation, while allowing the bolt to be installed using the same roof bolter and procedure as used for the standard roof support.

In order to thoroughly test these systems, the slow 120 second roof bolt resin was used. This allowed sufficient time for the dummy bolt to be spun in as per the installation procedure for the standard roof bolts, after which the bolt was withdrawn, cleaned and inspected. This procedure was repeated until the bolt had been subjected to 10 times the amount of spinning required for a single installation. The most abrasive resistant epoxy slot filling material was chosen for use on the bolts.

After delivery, the strain gauged bolts were calibrated at the CSIR rope testing division in a 1000 kN AMSLER testing machine. Using steps of 5.0 kN they were loaded to a maximum of 30 kN and then unloaded back to zero. This cycle was repeated three times. All the data gathered on each strain gauge was averaged and a factor established to convert the individual strain gauge readouts to kN. Taking the strength of the steel and the reduction in the cross sectional area due to the slot, which removed 12 per cent of the area, the bolt yield load was reduced to 123 kN and the ultimate strength to 167 kN.

3.11.1 Installation

The roof bolting crew were instructed to install the test bolts in the same manner that they installed the standard roof bolts

One 30 second capsule followed by three 120 second capsules were placed in the hole. The bolt was pushed in half way and spun in the rest of the way. Once the full length of the bolt had penetrated the hole, the spinning was stopped. After a hold time of 1.5 minutes the spinning continued which broke the crimp nut loose and tensioned the bolt until the roof bolter stalled. This required one to two revolutions and deflection of the washer was observed. After a total

time lapse of 2.0 minutes, a brief attempt was made to spin the bolt, presumably to check the bonding. The installation was then considered complete.

The bolts were installed approximately 1.5 m from the face. One was on the centreline and the other 1.0 m from the sidewall. Unfortunately, during the installation of the bolt near the sidewall, the plug socket attached to the top of the bolt came loose during the spinning process, damaged the wires and had to be abandoned. The remaining bolt was monitored over a 24 hour period during the face advance sequence illustrated in Figure 3.60. The total monitoring period covered 66 days, the results of which are presented in Figure 3.61.

3.11.2 Interpretation of the results

Volumetric calculations positioned the base of the 30 second resin column at approximately 110 mm below the number three gauge elevation. Whether there was a clear cut 30/120 second resin interface, or to what degree there was intermixing is not known. If it is assumed that gauges number one and two were well within the so called “end anchored” portion of the bolt, it is interesting to note that the pretensioning, initiated approximately 1.0 minute after the 30 second resin setting time, migrated to varying degrees into this region. These pretensioning values were 7.25 kN and 14.56 kN at the gauge one and two elevations, respectively.

Because gauge three was close to the resin interface, in the interpretation of the results it has been included along with gauges four to nine which indicate a more or less linear increase in the pretension load towards the collar of the hole, i.e. the source of the pretensioning. This could be due to the accumulative frictional effects of the resin and filler in the hole, increasing as a function of the distance from the source of tension. The fact that the 120 second resin was 90 seconds into its setting time before the tensioning was initiated may also have had an effect.

Gauge 10, 0.2 m in from the roof skin, indicated an initial pretensioning load of 33 kN. This was considerable higher than any of the other gauge levels. A possible explanation is that it was as a result of the bending of the bottom section of the bolt. If a hole is not exactly perpendicular to the roof skin or the roof surface is irregular, as is often the case, the final pretensioning tends to try and bias the end of the bolt to a position tending towards being perpendicular to the roof skin.

When the second set of readings were taken 12 hours after installation, without any face advance, all the gauges, with the exception of gauge number 10, exhibited a slight increase in load. This would appear to have been as a result of the bolt cooling down to the ambient rock temperature. The heat generated during the mixing and chemical reaction of the resin during its setting period would have been partially absorbed by the bolt and affected the readings taken immediately after installation. The pretension load over the entire length of bolt below the so called “end anchored” position was approximately 19 kN. A note made at the time of the experiment indicated that the pretensioning values were lower than expected. The roof bolter, in all probability, was designed to pretension to a load of 50 kN. The actual load measured in the bolt may have been influenced by the roof bolter setting or frictional effects within the system, including the resin or a combination of both.

In order to monitor the load change with face advance and time, the second set of readings (B) were taken as being the initial datum set and all the subsequent sets of readings were plotted relative to them. In Figure 3.59 the actual loads recorded after installation and during the 10 m face advance sequence are presented. On this same graph, the change in load relative to reading B, after the installation had stabilized, during the face advance are also included. The complete results of the changes in load of both the short term face advance and longer term time effects are presented in Figure 3.60.

Face advance pattern

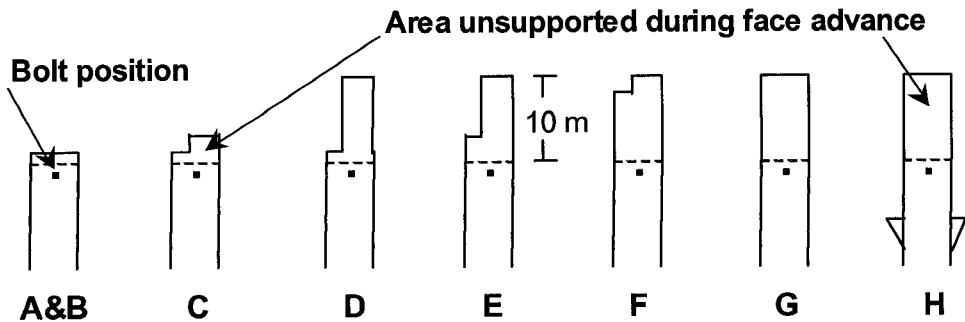

A = after installation
B = 12 hours later

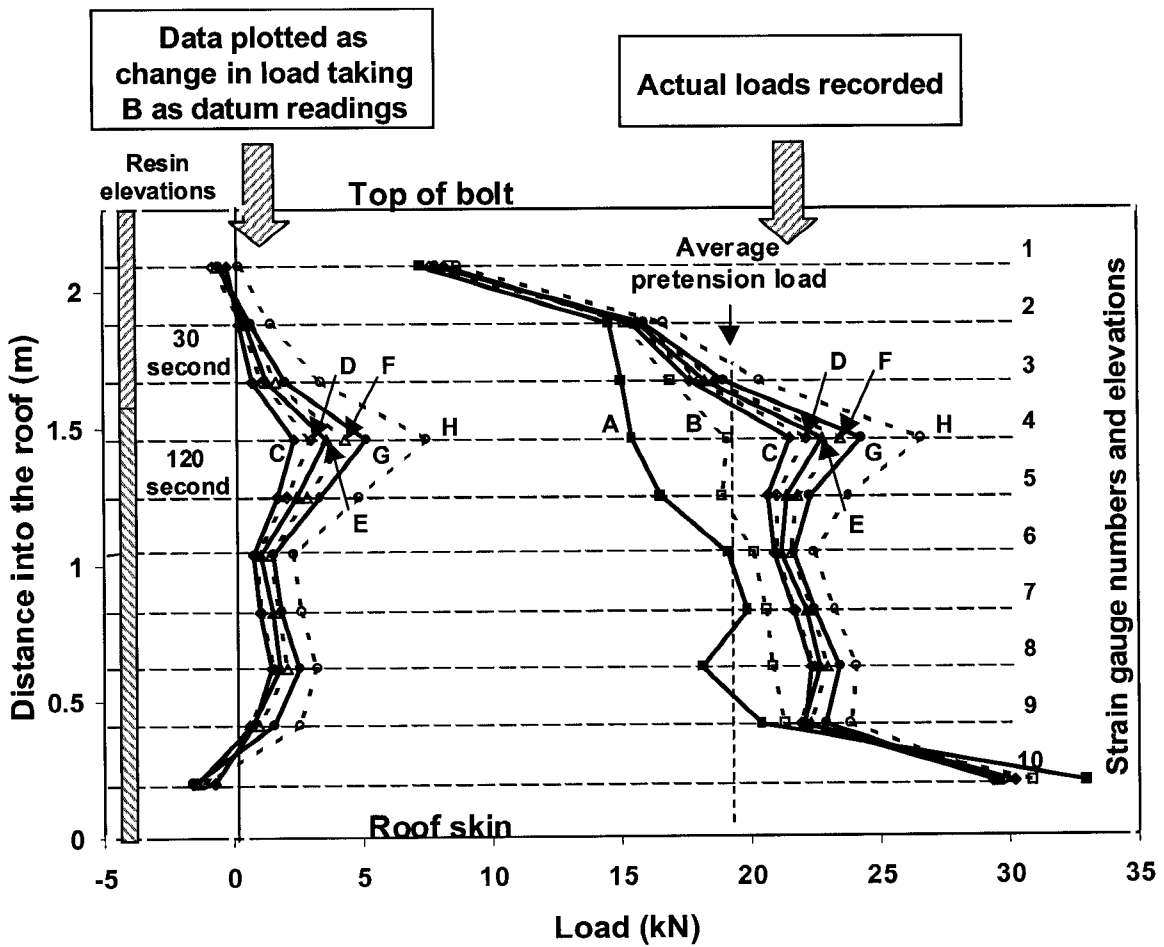

Strain gauged bolt short term performance 10 m face advance over 24 hours

Figure 3.60. Installation loads recorded and change in load with face advance

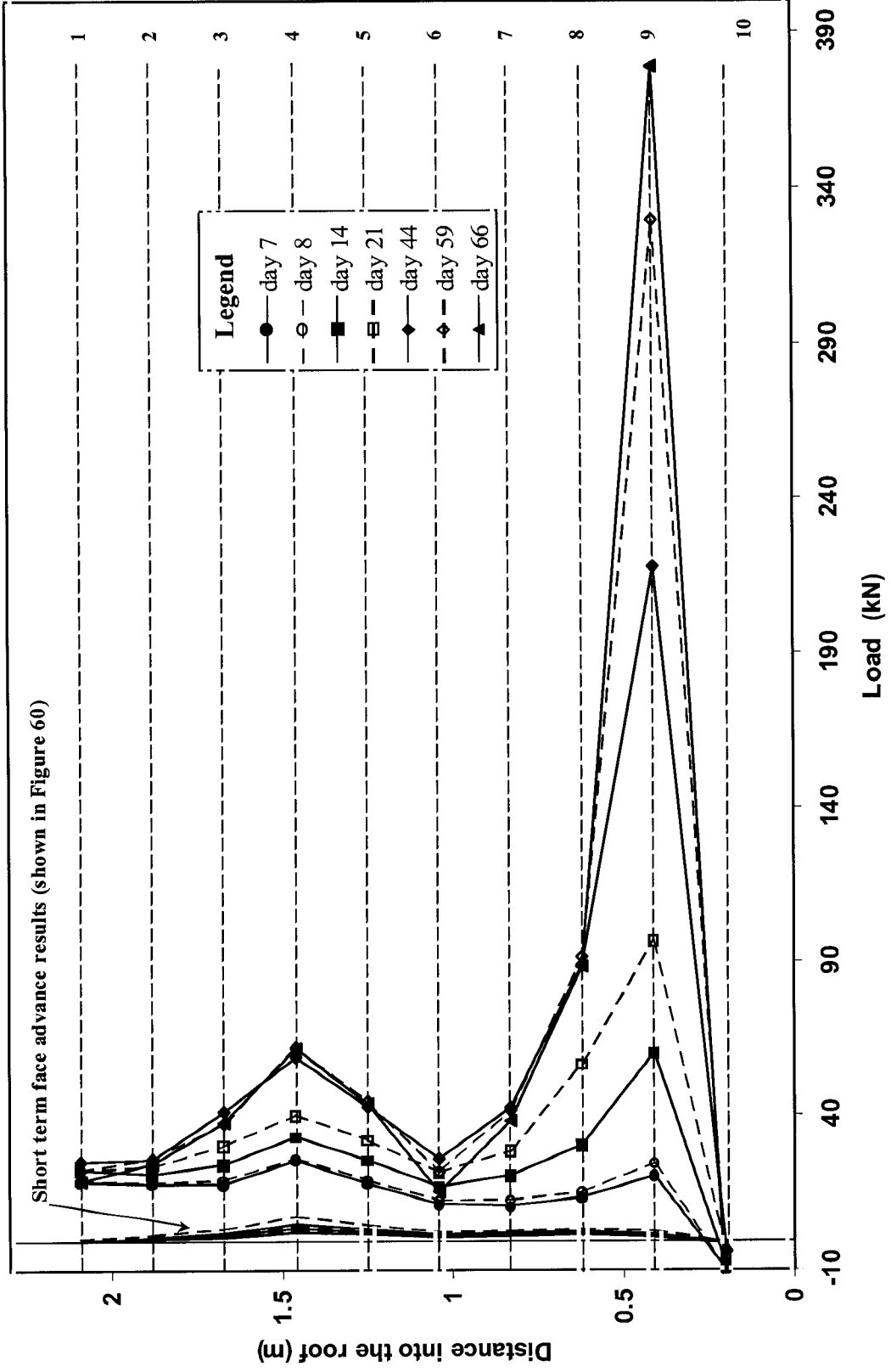

Longer term (time) effects on strain gauged bolt

Figure 3.61. Change in loads with face advance and time

The only really significant increase in load that occurred during the time that the face was advanced by 10 m occurred at the number four gauge elevation, approximately 1.5 m into the roof. Here the load increased by 7.5 kN. Five days later, with the face advanced in excess of 40 m (Figure 3.61), this value had increased to 25.8 kN and a similar profile was seen to be developing at the number nine gauge elevation 0.4 m into the roof. During this period there was a general increase in load throughout the bolt length of, on average, 12 kN, with the exception of gauge number 10 which experienced a drop off in load.

During the monitoring, the most dramatic increase in load was experienced at the number nine gauge elevation approximately 0.4 m into the roof. On day 66 the load increase had reached a value of 379 kN, more than twice the breaking strain of the bolt. The results were discussed with the load measuring specialist. Based on his considerable experience, the readings were in his opinion "real". If there is a breakdown of the bond of an otherwise intact strain gauge, it becomes obvious as it is accompanied by a usually massive change in reading followed by totally erratic behaviour. The vast majority of all the readings, particularly gauge number nine, followed a trend. The strain gauges used were linear up to five per cent elongation, which equated to an increase of 50000 micro strains. The largest recorded change was less than 10 per cent of this value.

The most appropriate explanation for this massive load increase at the number nine gauge elevation was that the strain gauge was positioned on the outside or convex side of a bend being induced in the bolt. Gravitational suspension of a slab of roof 0.4 m thick would be incapable of deforming a bolt to this extent. Horizontal or shear displacement induced by high horizontal stress, however, could quite feasibly distort and bend a bolt. Since this type of displacement had been observed in a number of inspection holes in the intersections, it is considered to be the most likely cause of the behaviour at the number nine gauge elevation.

Also of interest is the fact that the number nine gauge was not affected in isolation. Gauges seven and eight were also subjected to a similar load increasing trend. This may have been as a result of bending or a build up in the axial load due to horizontal displacement of wedge type failures in the roof. The highest total load reading indicated by gauge number eight was recorded on the second last visit at 112 kN, 11 kN below the bolt yield load and 55 kN below the breaking strain.

The position of gauge number four, close to the 1.5 m elevation, coincides with the highest elevation that displacements were observed in the inspection holes in the intersections. The highest total load recorded at this elevation was 81 kN. At this load level it is difficult to postulate whether it was largely attributed to bending or a build up in axial load due to the wedge type failure mechanism. Again it is significant that it was not a totally isolated phenomenon as gauges three and five, directly above and below it, were affected in a near linear sympathetic manner, as was the case with gauges seven, eight and nine.

If gauge number four was measuring a convex curvature in a manner similar to gauge number nine, it raises the question as to the behaviour at the number six gauge elevation. Could the 'drag' in the load build up here and the apparent reduction in load from day 44 be as a result of the load build up being masked by the possibility that this gauge happened to be positioned on the concave side of an induced bend in the bolt?

The performance at gauge number 10, the closest to the roof skin, was the least spectacular of them all. Other than a slight loss of load with time, it was basically static.

3.11.3 Additional instrumentation results

Sonic probe readings were only taken up until day seven. The results indicated that the total displacement between the 3.0 m elevation and the roof skin was 1.22 mm. This agreed closely with the levelling results, which indicate a value of 1.1 mm between the same elevations. The final levelling measurements were carried out on day 44. At that point in time, the total

displacement between the 3.0 m elevation and the roof skin was measured at 3.0 mm. The additional levelling point anchored at 1.5 m into the roof indicated that the entire 3.0 mm of displacement occurred below the 1.5 m elevation. This tends to agree with the strain gauged bolt results which indicated that most of the activity within the roof was within a similar horizon.

3.11.4 Conclusions

Although only a single bolt was successfully installed and monitored, the results indicated that this particular roof strata was active over the entire 66 day monitoring period.

The displacement mechanism at the 1.5 m elevation was initiated as the face advance began whereas that at the 0.4 m elevation appeared to be more time related or influenced by the mining on a macro scale.

The results can be explained by the roof behaviour observed in the inspection holes drilled into the roof in the intersections.

The need to have strain gauges on both sides of a bolt to differentiate between bending and axial load increases was highlighted. However, as previously mentioned, the primary aim of the experiment was to gain information on the initial load distribution in an end anchored pretensioned full column resin bolt as well as monitor any load increase that occurred. To do this, it seemed appropriate at the time to limit the strain gauge installations to one side of the bolt, bearing in mind that an additional slot would have reduced the overall bolt strength by a total of 24 per cent.

An oversight in this experiment was that the readout unit socket on the end of the bolt was not marked to indicate the position of the slot and strain gauges. It was therefore not possible to get any indication of the direction of the horizontal stress and shear displacements.

4 New support design approach

4.1 Introduction

The analysis of accident statistics covering the period 1989 to 1996 showed that falls of ground (FOG) is still the largest single cause for fatalities in South African collieries. As mentioned in Section 1, Vervoort (1990) stated that a person is often killed by a relatively small piece of rock. This has been confirmed by the analysis of FOG fatalities covering the period 1989 - 1995. The roof support design methods in South African collieries have been investigated with regard to their effectiveness in preventing FOG fatalities and to optimise the support in South African collieries. Two important issues, which are not in the current support design practice, have been highlighted:

- i) determining which type of support mechanism to apply in various geological conditions
- ii) the stability of the roof between the roof support.

4.2 Determination of support mechanisms

In South African collieries two roof support mechanisms have mainly been used, beam building and suspension. These mechanisms were explained in detail in Section 2. Experience has generally assisted rock engineers in deciding which support mechanism is appropriate. However when the inadequate mechanism is inferred failure of support and strata is possible. Therefore, design mechanisms have been investigated to evaluate their applicability.

Before a roofbolt pattern is designed for a certain mechanism, it is very important to establish the geology for at least 2.0 m into the roof, which will determine the support mechanism to be used.

In the suspension mechanism, the lower (loose) layer is suspended from the upper (competent) layer using roofbolts. This creates a surcharge load and increases the maximum tensile stress in the upper layer. This surcharged tensile stress can be calculated using the following formula;

$$\sigma_{xy(max)} = SF \frac{qg(t_{com} + t_{lam})L^2}{2t_{com}^2} \quad (\text{MPa}) \quad (4.1)$$

where,

SF	=	safety factor (1.5 - 2.0)
q	=	density of suspended strata (kg/m^3)
g	=	gravitational acceleration (m/s^2)
L	=	bord width (m)
t_{com}	=	competent strata thickness (m)
t_{lam}	=	laminated lower strata thickness (m)

Three design charts are given in Figures 4.1, 4.2 and 4.3 for bord widths 5, 6 and 7 m. These figures show that, for a given bord width, geology and tensile strength of material, the appropriate support mechanism can be determined.

These charts can be used to determine whether the upper, relatively competent strata will carry the extra surcharge load which is created by suspending the lower laminated strata onto this stronger strata. If the calculated load results in a tensile stress greater than the capacity of the competent strata, then beam building is recommended. If it does not exceed the tensile strength, then the strata will carry itself and the surcharged load and suspension mechanism may be used.

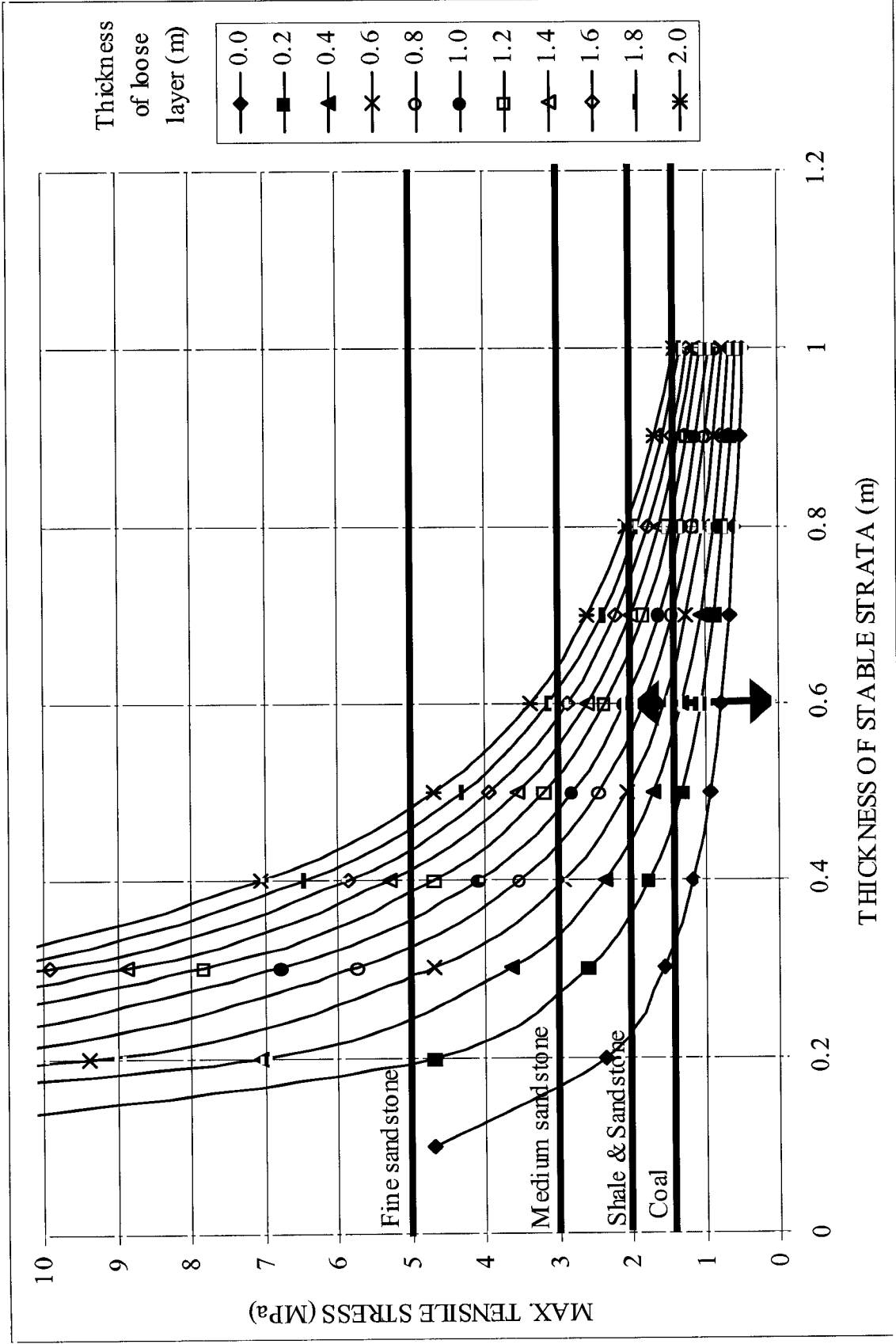

Figure 4.1. Support design evaluation chart for 5 m bord width

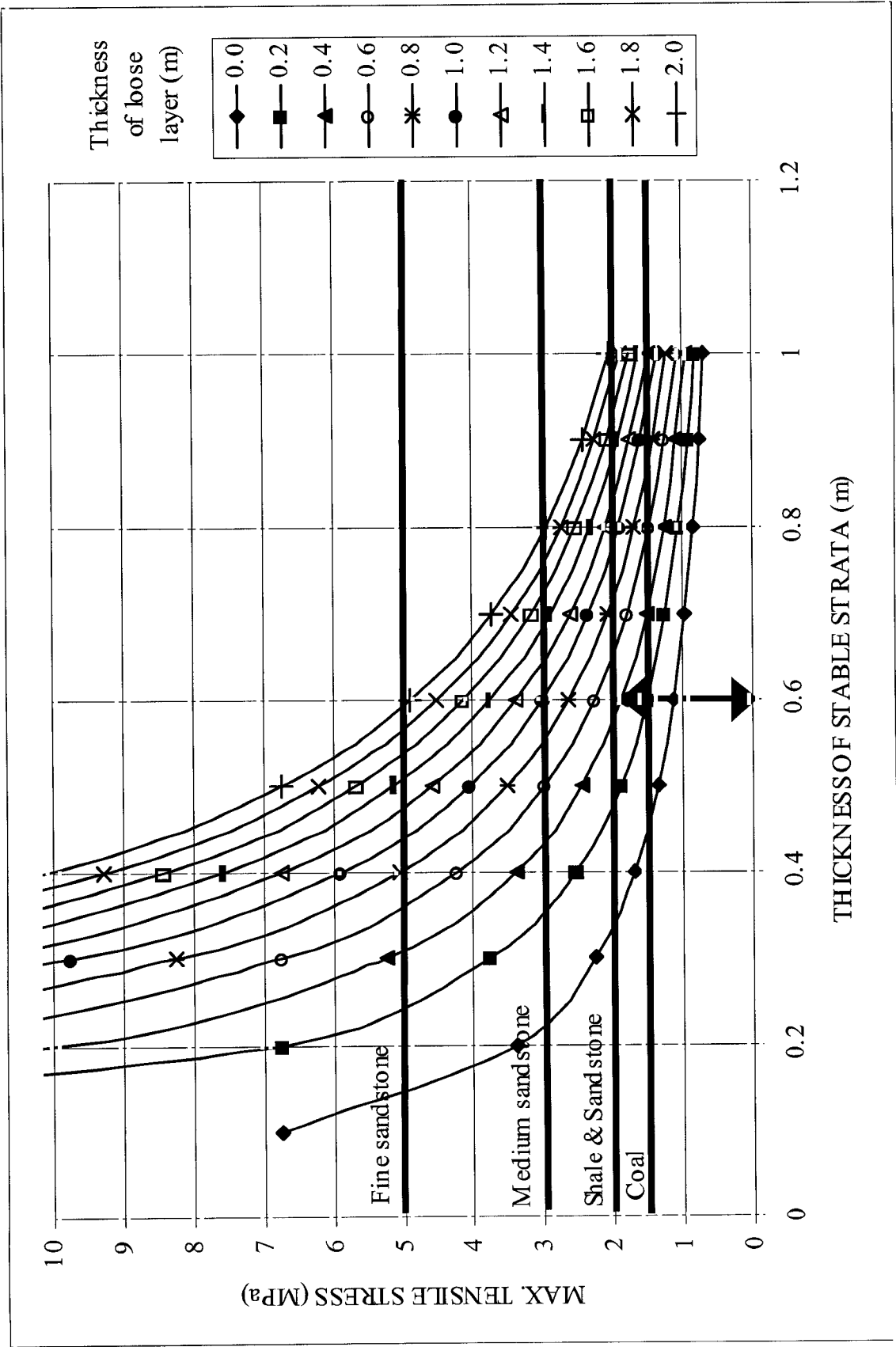

Figure 4.2. Support design evaluation chart for 6 m bord width

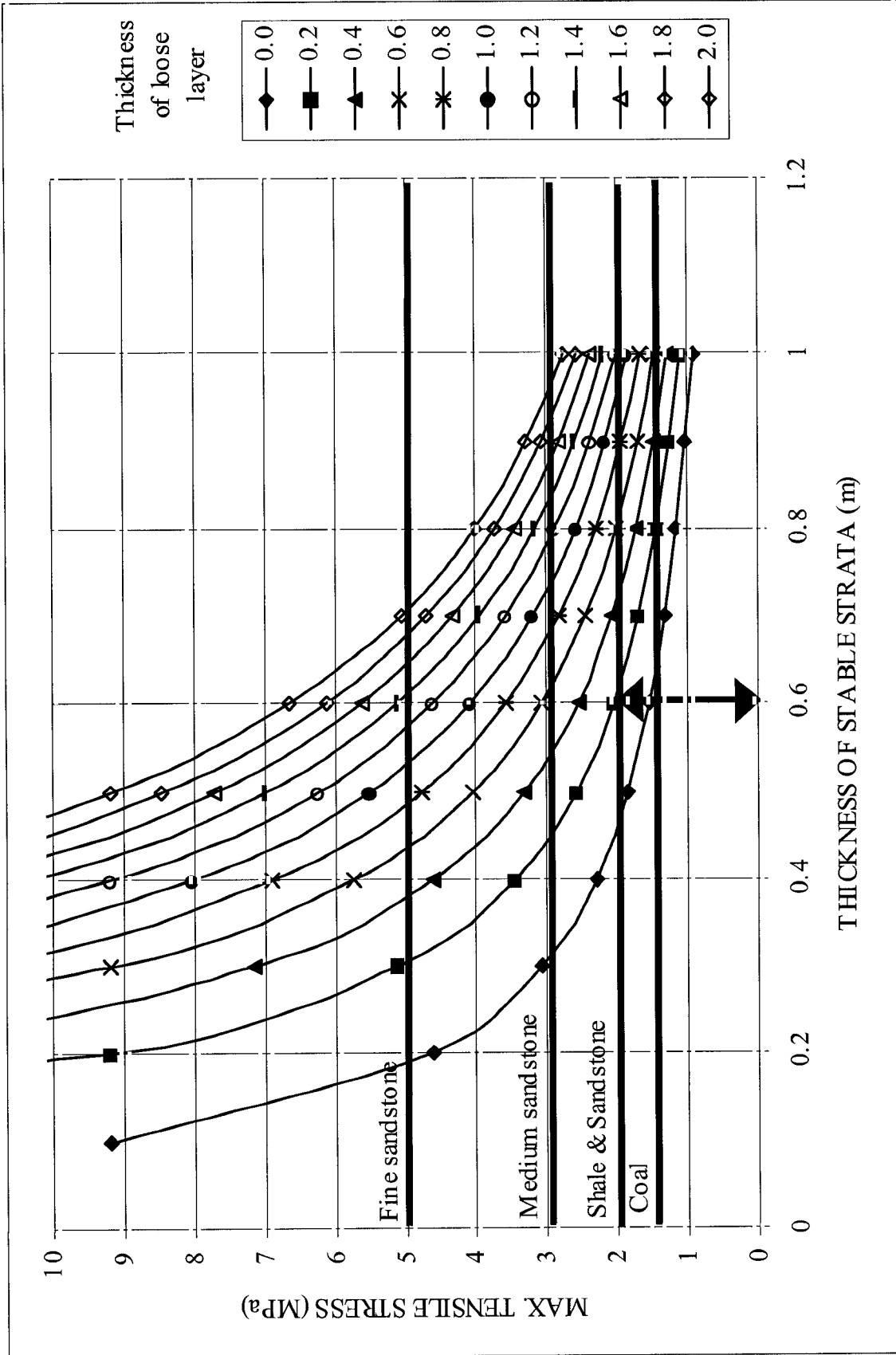

Figure 4.3. Support design evaluation chart for 7 m bord width

For example, in a 5.0 m wide roadway, a 0.6 m thick shale-sandstone layer can carry a suspended lower layer (with $q=2500 \text{ kg/m}^3$) with a maximum thickness of 1.0 m (Figure 4.1). If the suspended layer is thicker than 1.0 m, then the beam building mechanism should be used to avoid failure of the shale-sandstone layer. Similarly, from these charts, for 6.0 and 7.0 m wide roadways, a 0.6 m shale-sandstone can carry a maximum of 0.4 and 0.2 m thick layers respectively, Figure 4.2 and 4.3.

4.3 Determination of stability of the immediate layer

To prevent the failure of the immediate roof between the bolts, the tensile stress between the bolts for the immediate layer may be calculated by assuming that the bolts create a fixed beam between them. If the tensile stress between the bolts exceeds the tensile strength of the material then the distance between the bolts should be reduced or an areal coverage system should be used. The tensile stress may be calculated from:

$$\sigma_{xy(max)} = SF \frac{qgL^2}{2t^2} \quad (\text{MPa}) \quad (4.2)$$

where,

SF	=	safety factor (1.5 - 2.0)
q	=	density of immediate layer (kg/m^3)
g	=	gravitational acceleration (m/s^2)
L	=	distance between the bolts (m)
t	=	thickness of immediate layer (m)

This approach can be used for both the suspension and beam building mechanisms.

A design chart to determine the stability between the bolts is given in Figure 4.4. The upper right hand side of this chart represents the fixed parameters: the thickness and the density of layer. The upper left hand side represents the controllable parameter of distance between the bolts. The lower left hand side indicates the stability of the layer between the bolts together with safety factors for given tensile strengths. An example is given in this figure for a layer with thickness of 0.25 m, density of 2500 kg/m^3 and a tensile strength of 2.0 MPa. As can be seen, for a safety factor of 2.0, while the distance between the bolts is 4.0 m, the layer will be stable, if it is 5.0 m the layer will fail. Similarly, for a safety factor of 4.0, the layer will fail for both distances, and only 3.0 m distance between the bolts will provide the stability. In a similar study, Herget, 1988, recommended a safety factor of 4.0 to 8.0 to cover unforeseen geological defects in the roof.

These new design approaches are based on the tensile strength of the material. However, the tensile strength is one of the most difficult rock characteristics to determine. In practice, 1/10 of the uniaxial compressive strength (UCS) is taken as the tensile strength of the materials. However, laboratory testing is recommended to more accurately determine the tensile strength of the various coal strata materials. This design chart is based on purely gravitational loading conditions. The effects of horizontal stress would obviously further reduce the acceptable distance between the bolts.

Once all these calculations are made, the roof support can be designed for suspension or beam building. However, these calculations are not the only parameter required for ensuring a safe and stable mine roof. The quality of the support installation also plays a very important role in stability. As part of this project, a series of roofbolt pull tests was conducted at a single colliery, on over 200 bolts, where mechanical anchors were used in the suspension mode. The bolts are intended to be tensioned up to 5.0 tons. The results are shown in Figure 4.5. As can be seen, 80 (37 %) of the bolts did not develop any load, 190 (89 %) of them slipped after application of 2.0 tonnes pull-out load and none of them reached the prescribed 5.0 tons load. This highlights the importance of selecting a suitable support system for different strata conditions and/or quality of installation.

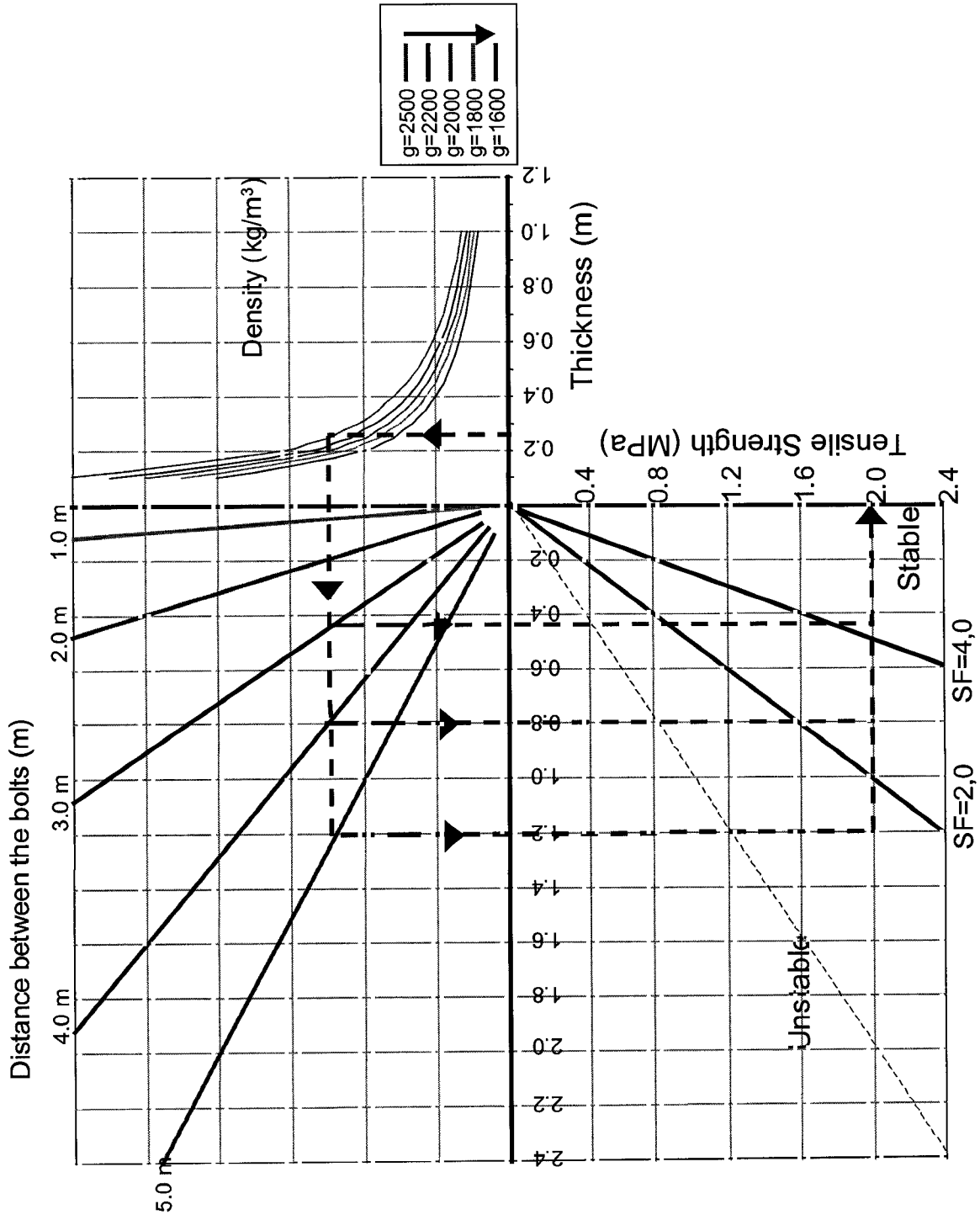

Figure 4.4. Design chart to determine the stability of roof strata between the bolts

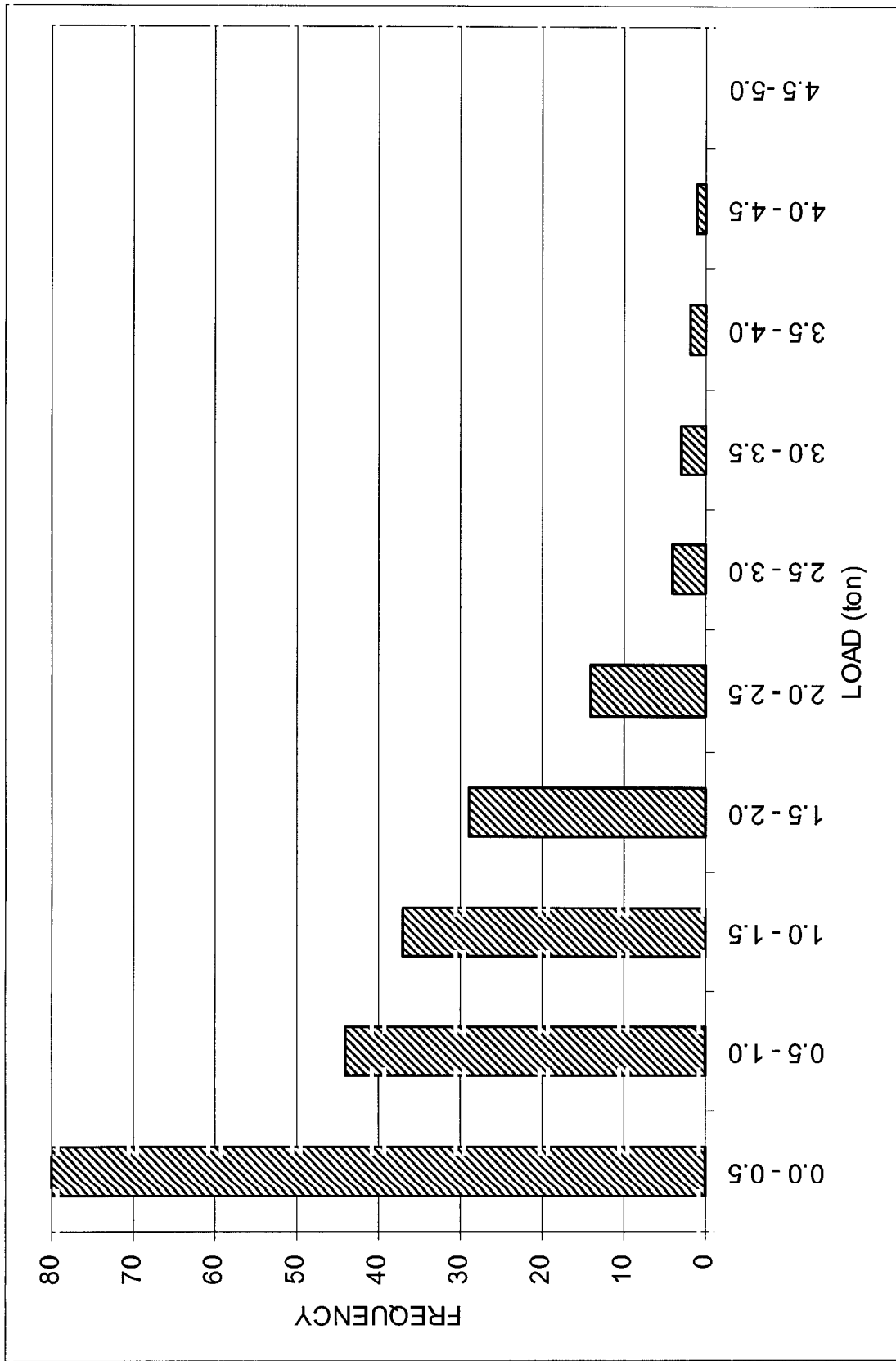

Figure 4.5. Roofbolt pull-test results

In South African collieries, the mechanical end-anchors have been successfully used for many years. The key component of the system is an expansion shell which is positioned at the top of the hole. The expansion shell expands as the bolt is tightened. Because of high contact stresses which develop at the position of the end anchor, Wagner (1995) suggests using this type of support in rock strata which has a uniaxial compressive strength of more than 50 MPa.

One other important factor in the stability of the workings is the control of the mining dimensions in the underground environment: pillar width, bord width and mining height.

While these three parameters are the most important parameters in calculating the safety factor of pillars, the bord width controls the stability of the roof.

The basic beam equations for gravity loaded beams with clamped ends are:

$$\text{Maximum bending stress} \quad \sigma_{xy(max)} = \frac{qgL^2}{2t} \quad (\text{MPa}) \quad (4.3)$$

$$\text{Maximum shear stress} \quad \tau_{xy(max)} = \frac{3qgL}{4} \quad (\text{MPa}) \quad (4.4)$$

$$\text{Maximum deflection} \quad S_{max} = \frac{qgL^4}{32Et^2} \quad (\text{mm}) \quad (4.5)$$

where L = roof span (width of roadway)
 t = thickness of roof layer
 q = density of suspended strata
 g = gravitational acceleration

Figure 4.6 shows the rapid increase in the beam deflection, bending stresses and shear stresses with increasing bord widths.

These figures highlight the importance of variation in bord width. Any change in bord width will significantly affect the strata response to load. For example, a 33 per cent increase in bord width from 6 to 8 m results in a:

- 216 per cent increase in roof deflection
- 78 per cent increase in roof bending stress (tensile stress)
- 33 per cent increase in shear stress over the roadway abutments.

An investigation into bord width has also been conducted and bord width offsets were measured in a colliery. A frequency versus bord width graph is given in Figure 4.7. In this colliery the bord widths are designed to be 6.0 m, but, in reality varied from 5.0 to 8.2 m. Problems with 5.0 m wide bords will not be as significant as bord width of 8.0 m. Although the average bord width of 6.2 m is close to the designed 6.0 m the spread from 5.0 to 8.2 m indicates a lack of discipline during the mining operation. The narrower than average bord widths may affect tramming and ventilation. The 50 per cent of roadways wider than 6.0 m will have a detrimental effect on roof stability, as they are not catered for in the support design procedure. The corresponding increased probability of roof falls has major safety implications.

These results highlight the importance of quality of installation and selection of the correct support system for the strata as well as control of the dimensions. If the installation is poor or incorrect, no matter how good the design is, the roof will fail and create an unsafe environment.

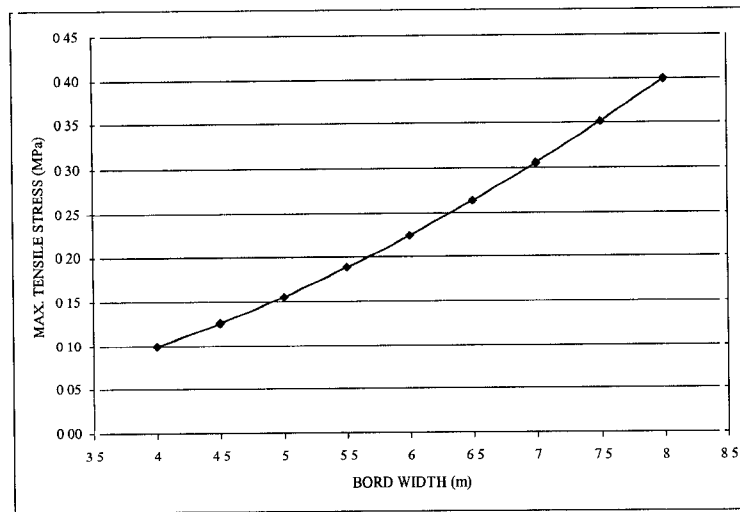

a) Maximum tensile stress

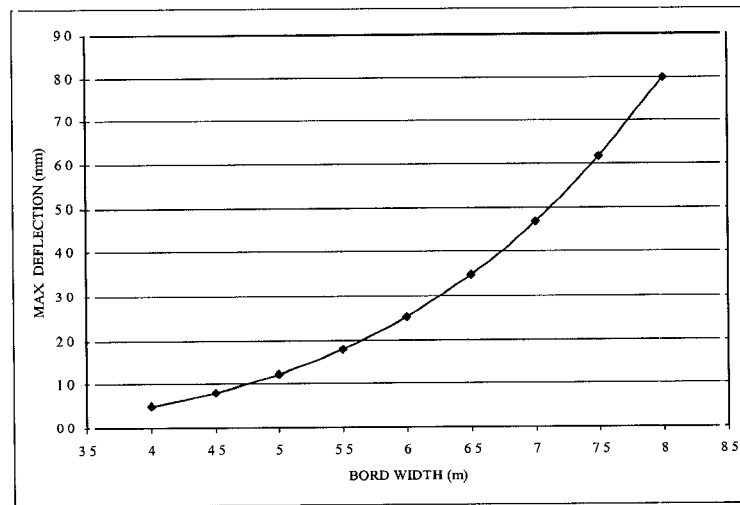

b) Maximum deflection

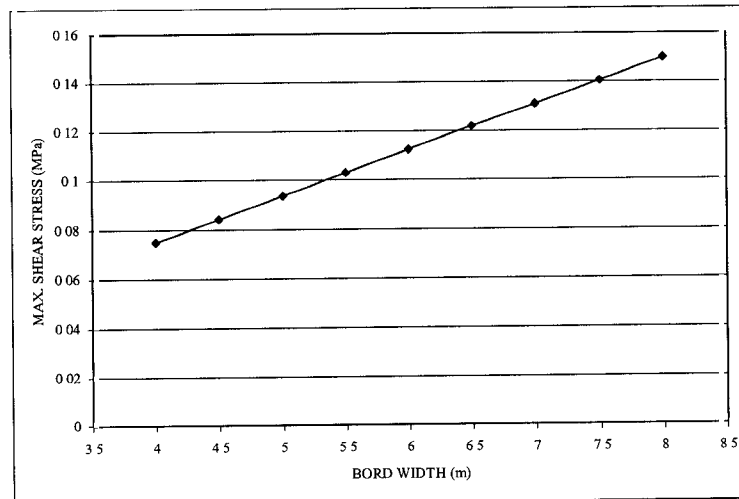

c) Maximum shear stress

Figure 4.6. Increase of the beam deflection, bending stresses and shear stresses with increasing bord widths.

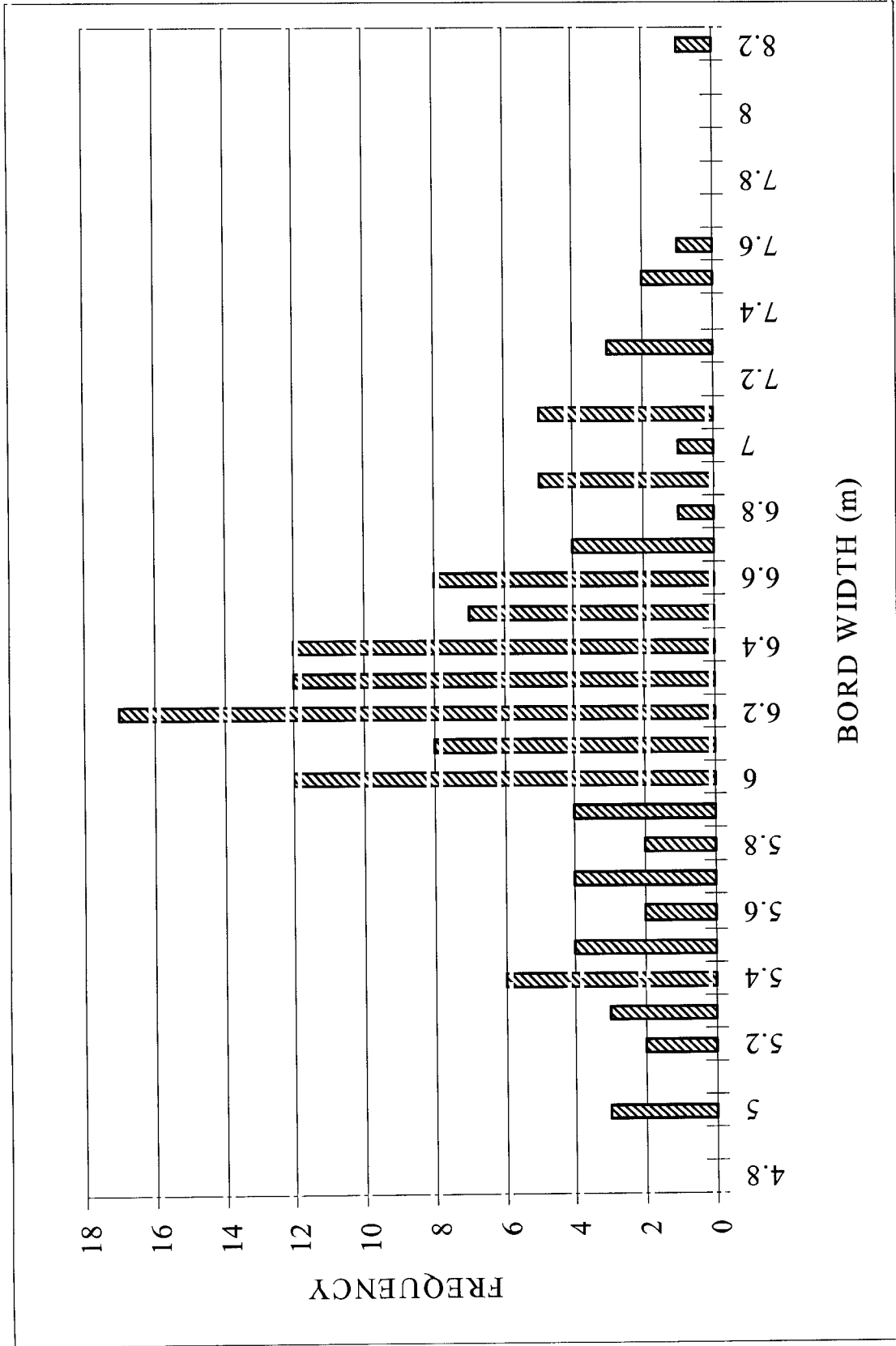

Figure 4.7. Bord width versus frequency

4.4 Conclusions

The new design charts for surcharge load, induced by the suspension support method, highlighted the importance of the thickness of the competent strata. These charts can be used to determine the appropriate design mechanism, which will assist the rock engineer to create a safer and more stable environment.

Distance between the bolts is also an important factor. The tensile stress in the immediate roof layer between the bolts should be calculated and compared against the material's tensile strength to determine the stability of the exposed roof between the roofbolts.

The quality of the installation of the individual roof support elements is as important as the overall roof support design. The installation and support performance should be monitored using suitable extensometers or tell tales in a similar manner to the Australian and U K procedures, i.e. the installation and reading frequency of each device being dictated by additional risk factors such as the effects of high horizontal stress and geological disturbances.

With the suspension based support system the load carrying capacity of individual bolts is directly related to the areal coverage. If the bord width is increased and the distance between rows remains the same the additional load resulting from an increase in the area now requiring support is transferred to the roof bolts and could exceed their strength resulting in a major roof collapse. In the case of the beam building support system any increase in bord width would result in larger beam deflection magnitudes which in turn would induce higher tensile stresses in the roof skin again increasing the risk of roof falls.

The importance of controlling the bord widths to match their design dimensions needs to be brought to the attention of the mining industry as a whole.

5 Conclusions and recommendations for future research

5.1 Conclusions

The following is a summary of the major conclusions of the project with respect to the enabling outputs defined in the project tender document.

Update fall of ground accident statistics.

Analysis of accidents to identify future areas for research showed that improved reporting of FOG fatalities is required and that data, such as face advance distances before support installed, mining method, support type, geological discontinuities, immediate roof and location, to normalize various aspects of accidents needs to be collected industry-wide.

Fall of ground fatalities covering the period 1989 - 1996 were investigated. The results showed that the number of fatalities and injuries decreased on average for the period 1989 – 1996 compared to the period 1970 – 1989. However, fall of ground accidents still remain the largest single cause of fatalities and injuries in South African collieries. The risk involved in producing a ton coal has decreased from 0.0007 to 0.0001 with time. However, the risk to individuals going underground has not shown a significant increase or decrease over the 27 year period.

The results also indicated that 54 per cent of the total number of collieries were responsible for all the FOG fatalities for the period 1989 – 1996. In some coalfields the percentage of the total fatalities exceeded their percentage contribution to South African coal production. This highlights an issue which requires urgent attention in these coalfields.

The analysis also highlighted the following points;

- The effectiveness of roofbolt design and its implementation needs to be improved.
- Seventeen per cent of fatalities occurred where no temporary support was installed.
- Slips, joints and faults were associated with more than 50 per cent of fatalities, while 20 per cent were caused by failure on bedding planes. Support design to improve stability in the presence of joints needs to be investigated.
- Improved training is indicated to be an important factor and necessary for the reduction in FOG fatalities. People working at the face are at a higher risk than the other job categories. Therefore, focused training programmes particularly for people working at the face, should be devised and implemented.
- The high proportion of fatalities associated with sandstone roofs, 33 per cent, is perhaps surprising as this type of roof is generally considered to be stable. The reasons for this need to be determined.
- While 60.7 per cent of the FOG fatalities occurred in the intersections and roadways, 25.3 per cent of FOG fatalities occurred at the face.
- The stooping method is indicated as the most dangerous exploitation method with regard to falls of ground in South African collieries.

Documentation of world wide roof support design methods.

The literature review showed that three main rock reinforcement techniques have been used in coal mining applications - beam building, suspension and rock strengthening.

While the beam building and suspensions modes are applicable in conditions where the stresses and deformations are relatively small, rock strengthening or reinforcement is mainly applicable where deformations and stresses are high.

In South Africa and the US, support design is most commonly based on beam building and suspension, while, for Australian and UK conditions, the rock strengthening technique is used. Underground monitoring of roof behaviour showed that South African roof behaviour is characterized by low deformation. This indicates that, in most instances, the roof fall failure mechanism is not related to high horizontal stresses, but rather due to simple gravity loading.

While beam building designs are based on empirically based calculations, rock reinforcement or strengthening is based on in situ monitoring and numerical modelling. However, extensive studies by Vervoort showed that the material properties used as input parameters in numerical modelling can affect the results significantly. Using wrong values for parameters will give completely misleading results, which will affect the design. However, the Australian technique subsequently adapted in the UK has proven that numerical modelling can be used to simulate and back analyse the underground conditions to calibrate the model. Once the model is calibrated then the results obtained from the numerical models can be used for design.

The stress magnitudes and directions are also found to be very important parameters in the design of roof support. Therefore, extensive stress measurements are recommended when applying the rock reinforcement method. Obtaining this information assists the rock engineer with the general design. However, changing conditions underground must be determined and the design has to be modified accordingly. Therefore, not only widespread instrumentation, but also vigilant visual observations are important under these conditions to ensure safety and stability.

The literature review also highlighted the importance of identifying the roof failure mechanisms and then establishing deformation criteria and other visual indications of impending instability that can be used by production personnel to initiate appropriate actions to control the hazard. Therefore monitoring must be conducted to identify the roof behaviour in a certain area. In South African roof conditions monitoring will give very useful information for identifying and assessing roof behaviour in different strata. However, to involve the underground work force as a whole in contributing to improving safety with regards to FOGs, relatively simple visual indicators (tell tales) to monitor roof and support behaviour is recommended. Installed and observed routinely, such a device can give an early warning of changes in roof conditions. By reacting as soon as possible to these changes, barring down or the installation of additional support could prevent an imminent roof fall.

Underground field trials to establish strata behaviour including the influence of road width, and analysis of results.

The sonic probe extensometer, which was found to be the most accurate and reliable instrument capable of monitoring roof behaviour up to 7.2 m into roof, was used throughout the underground monitoring programme. To process the monitoring data as quickly and efficiently as possible, a customised program was written in house, culminating in an easy to understand set of graphic results. The basic function of this program is to compare all subsequent sets of readings with the original set and produce displacement-with-time graphs. Various modifications and improvements were introduced to include the option of producing velocity and acceleration graphs to assist with the interpretation of the results. This program can be obtained from CSIR-Miningtek.

An extensive underground roof monitoring programme was conducted. Results showed that, in drill and blast sections, there is usually at least one pre-existing opening present in the roof

virtually at the face which has an effect on the overall roof stability. As a result of these openings in drill and blast sections 42 per cent of the total displacement took place prior to the installation of support.

The other factor linked to, and affected by an increase in span, is the height to which the openings migrate in the roof, i.e. height to which instabilities could occur. In more than 80 per cent of the monitoring sites all the displacements measured in the roof were confined to within 2.5 m of the roof skin. The height of instability in the intersections was compared to that in the roadways with the elevation differences being converted to percentages. These differences were relatively small, varying between -5.0 and 33 per cent with an overall average of 13 per cent.

In the vast majority of cases the stable elevation in the roof was fully developed a short distance behind the face. In the drill and blast sections, the stable elevation was reached after a single blast, where the face advance increased the unsupported span to 3.0 m on average.

In the continuous miner sections, it was difficult to accurately determine at what point the stable elevation had fully developed. The reason was that half the face was usually advanced by up to 7.0 m in a single cutting sequence. After the installation of the support, the other half of the face was then advanced a similar amount before it was practical to access the sonic probe hole and take a set of readings. However, at some of the sites where the face was only advanced by 4.0 or 5.0 m (Colliery 'D' area one, site four; area two, site four, and area two, site five. Figures 3.25, 3.31 and 3.32), the stable elevations were already fully developed.

The only two monitoring sites that indicated obvious increases in the height at which displacement occurred in the roof as further mining occurred, were both in the partial column resin supported roof at colliery 'D' (area two - sites two). Both sites were in intersections that had total relaxations amongst the highest recorded. Their total relaxation values had reached 11 and 5.0 mm respectively prior to the migration of the stable elevation occurring. Both the stable elevations increased quite significantly by approximately 0.5 m and 0.25 m, respectively. Since this occurred well outside the face advance zone of influence at between 56 m and 166 m and 28 m and 158 m respectively, it appeared to be time dependent behaviour.

A comparison between the roadways and intersections indicated that for a 40 per cent increase in the span, taken across the diagonal of an intersection, relative to the roadway span, the magnitude of the displacement in the roof increased by a factor of three.

An investigation into the time effects of a static face indicated that close to a static face (within 0.5 m), the roof does not deform significantly. If a face remains static, the roof within its zone of influence (approximately 5.0 m away) experiences some degree of creep with time. An area of roof outside the zone of influence of the face (11 m away) is not affected by the face irrespective of whether it is stationary or mobile.

The monitoring results at the 29 sites at five collieries showed that there was no evidence of a dramatic increase in the stable elevations as is the case in the high horizontal stress driven beam buckling mechanism experienced in overseas collieries.

Comparison of underground monitoring results with analytical and numerical methods showed that numerical modelling resulted in much less variation than the analytical solutions and in 60 per cent of the cases provided results which better matched the in situ results. Results also showed that there are many parameters which can effect the overall roof stability. The effects of many of these parameters are unknown and are not incorporated in the current design methodology. These parameters need to be investigated and their effects need to be established. The benefits of 3D modelling also need to be determined.

A roadway widening experiment was carried out to establish the critical roof displacements. The maximum width attained was 12 m at which stage ± 5 mm displacement was measured. No roof

falls had occurred. However in the same panel falls had occurred at 6 m widths where a slip had been reported. Also, falls took place in some of the areas where evidence of high horizontal stress had been noted. This indicates the variations that occur in a single mining area.

During the monitoring period no roof falls occurred at any of the 29 sites and road widening experiment site, even where 12 mm displacements were measured. As a result it was not possible to try and establish critical roof displacement values for any of the geological regions. However, Amcoal rock mechanics department measured 5.0 mm of roof skin displacement prior to a fall. This incident suggested to them that the critical roof skin displacement in this particular area was of the order of 5.0 mm. This finding highlights the site specific and geologically dependant nature of roof failure.

Optimisation of design.

New design charts for surcharge loading have been developed. These highlighted the importance of the thickness of the suspending competent strata. These charts can be used to determine the support design mechanisms which will improve the stability and safety in South African collieries.

The distance between the bolts is also an important factor for stability and safety. The analysis of FOG fatalities showed that most of the FOG fatalities occurred due to relatively small pieces falling between the roofbolts. A design chart has been developed to determine the stability of the roof between the roofbolts and hence the appropriate spacing of bolts.

The quality of installation of roof support elements was also found to be as important as support design. The installation and support performance must be monitored using extensometers, and in the case of poor conditions being identified, additional precautions must be taken.

With the suspension based support system the load carrying requirement of individual bolts is assumed to be directly related to the tributary area. If the bord width is increased and the distance between rows remains the same the additional load resulting from an increase in the area now requiring support is transferred to the roof bolts and could exceed their strength. In the case of the beam building support system any increase in bord width would result in larger beam deflection magnitudes which in turn would induce higher tensile stresses in the roof skin, again increasing the risk of roof falls. This highlights the importance of control of dimensions in underground environment.

Although, several design charts have been developed and data requirements identified for a support design methodology for South African conditions, the effects of many relevant parameters identified during this project have not been studied in detail. These have been discussed in Section 5.2 (Recommendations for future research). Until this further research have been completed, it will not be possible to develop a new, comprehensive design methodology for the support of South African collieries. However, the design charts produced as part of this project can be used by rock engineering practitioners to improve support design.

Transfer of technology

Findings of this project were presented at the SANGORM annual meetings and mining houses. In addition, the frame work for a computer program, which integrates previous design methods with outputs from this project to provide improved roof support design, has been established. On completion, the computer program will simplify the design of support, as only few basic input parameters are required. This will greatly assist the transfer of technology to mining personnel.

5.2 Recommendations for future research

From an analysis of FOG fatalities, it is clear that the design and implementation of support systems require further investigation. Currently support design methods are based on 2D analysis. A full 3D analysis of the behaviour of roadways as well as of intersections is required.

The influence of different strata conditions on this behaviour needs to be determined to facilitate better support design and installation rules in order to improve overall stability and to reduce accidents due to roof falls.

In the current design methods, which are based on analysis of the interaction of two beams, the following assumptions are made

- i) Each stratum is homogeneous, elastic and isotropic,
- ii) There is no bonding between the strata, i.e. bedding planes have parted and friction and cohesion are zero;
- iii) Each stratum is subjected to uniform loading in both the transverse (due to self weight) and axial (due to horizontal stress) directions simultaneously
- iv) When the upper stratum loads onto the lower stratum, the deflections of the two strata are equal at each point along the roof span and
 - a) The upper beam loads the lower beam with a uniform load per unit length of beam,
 - b) The lower beam supports the upper beam with an equal load per unit length

These assumptions and their effects on roof behaviour require more detailed analysis.

The effect of drill-and-blast methods on roof stability and support performance also needs to be confirmed and further elucidated by more detailed investigations.

The effect of different support and interaction between the support elements needs to be investigated. This will assist in determining the optimum spacing between bolts.

The effect of time is also important for stable and safer workings. Therefore, the effect of time on support performance needs to be evaluated.

The different roof strata encountered in the coalfields are likely to have a significant influence on the deformation rates, and thus monitoring should be carried out in all the important geotechnical areas. The quantitative influence of slips, joints and other geological discontinuities is also unknown and should be evaluated.

A database needs to be established with regards to the early detection of high horizontal stress areas so that an appropriate support system can be installed as soon as practically possible.

The subtle indicators that lead to the early detection of high horizontal stress areas needs to be investigated and documented to enable less experienced personnel throughout the coal mining industry to benefit.

6 Reference

Blackwood, R. L. and Binns, V. J. (1987), Rock bolt performance in coal mining: A review. The Coal Journal, No 15.

Bolstad, D. D., Hill, J. R. M. and Karhnak, J. M. (1983), US Bureau of Mines rock bolting research. Proc. Internat. Smp. On Rock Bolting (O. Stephansson, ed.), Abisko, Sweden, pp. 313-320.

Buddery, P. (1989), Fundamental principles of roofbolting in South African Collieries. Advances in rock mechanics in underground coal mining. SANGORM Symposium, September.

Buddery, P. S. and Oldroyd, D. C. (1992), Development of roof and floor classification applicable to collieries. Eurock'92. Thomas Telford, London.

Butcher, R., Australian roof support techniques. Unpublished report, Angus Place Colliery.

Deep Mines Coal Industry Advisory Committee, (1996), Guidance on the use of rockbolts to support roadways in coal mines. HSE Books, UK.

Department of Mineral and Energy Affairs, (1993). South African Mines Reportable Accidents Statistics System (SAMRASS). Reportable accidents data and code book. Government Mining Engineer.

Gale, W., Fabjanczyk, M. W., Tarrant, G. C. and Guy, R. J., Optimisation of reinforcement design of coal mine roadways. ACIRL.

Galvin, J., (1995), Roadway and pillar mechanics workshop, University of New South Wales.

Herget, G., (1988), Stresses in Rock. A.A. Balkema, Rotterdam, Netherlands.

Hoek, E. and Brown, E. T., (1980), Underground excavations in rock. Institution of Mining and Metallurgy.

Luo, J., Haycocks, C., Karmis, M. and Westman, E., (1988), A critical overview of U.S. rock bolting practices. Third International Symposium, Roofbolting in mining. Aachen Germany, June 3 – 4.

Madden, B. J. (1997), Rock mechanics course for coal mines. CSIR:Division of Mining Technology, Johannesburg, South Africa.

Madden, B. J., (1989), Squat pillar design in South African collieries. In Proceedings of the SANGORM Symposium "Advances in rock mechanics in underground coal mining", Witbank, September 12, p. 83-90.

Minerals Bureau, (1989, 1990, 1991, 1992, 1993, 1994, 1995, 1996, 1997). Operating and developing coal mines in the Republic of South Africa.

Obert, L. and Duvall, W. I., (1967), Rock mechanics and the design of structures in Rock. John Wiley and Sons, U.S.A.

Ozan, T. T. and Madden, B. J., (1991), A Study on Underground Mining Dimensions and Production in South African Collieries. Turkey.

Panek, L. A. (1956), Principles of reinforcing bedded mine roof with bolts. U.S. Bur. Min. Report of investigations No. RI 5156.

Panek, L. A. (1962), The combined effects of friction and suspension in bolting bedded mine rocks. U.S. Bur. Min. Report of investigations No. RI 6139.

Panek, L. A., (1956 (a)), Theory of model testing as applied to roof bolting. U.S. BurMines Rept. Invest., 5154.

Panek, L. A., (1956 (b)), Design of bolting systems to reinforce bedded mine roof. U.S. BurMines Rept. Invest., 5155.

Panek, L. A., (1956 (c)), Principles of reinforcing bedded mine roof with bolts. U.S. BurMines Rept. Invest., 5156.

Panek, L. A., (1957), Anchorage characteristics of roof bolts. Mining Cong. J. November.

Panek, L. A., (1962 (a)), The effects of suspension in bolting bedded mine roof. U.S. BurMines Rept. Invest., 6138.

Panek, L. A., (1962 (b)), The combined effects of friction and suspension in bolting bedded mine roof. U.S. BurMines Rept. Invest., 6139.

Panek, L. A., (1964), Design for bolting stratified roof. Trans. SME-AIME, 229.

Peng, S. S., (1986), Coal mine ground control. A Wiley-Interscience publication, John Wiley and Sons, U.S.A.

Siddall, R. G. and Gale, J. (1992), Strata control – A new science for an old problem. Inst. Of Min. Eng. and Ins. Min. and Metall. UK, January.

Syddell, M., (1998), Ground control innovation keeps Angus Place mining. Australian Mining, vol. 90 No 5.

Spann, H. P. and Napier, J. A. L. (1983), The influence of different bolt patterns and anchor types on the deflection of a laminated beam.

Van der Merwe, J. N. (1995), Practical coal mining strata control. A guide for managers. Johannesburg, South Africa, November.

Van der Merwe, J. N. (1989), A probabilistic approach to the design of coal mine roof support systems. Advances in rock mechanics in underground coal mining. SANGORM Symposium, September.

Vervoort, A. and Jack, B. (1991), Optimization of support in roadways and intersections of South African collieries. International conference on Reliability, Production and Control in Coal Mines. Wollongong, New South Wales, Australia, September.

Vervoort, A. and Jack, B. (1991), Room and pillar strata behaviour under various conditions. 7th International Congress on Rock Mechanics. Aachen, Germany, September 16 – 20.

Vervoort, A. M. J. (1990). Falls of Ground In South African Collieries During the Period 1970 – 1988. Part 1: Review of Fall of Ground Fatalities and Injuries. COMRO Internal Report, Project Report No. 5/90, Project No. CC8S03, January.

Vervoort, A. M. J. (1990). Falls of Ground In South African Collieries During the Period 1970 – 1988. Part 2: Description of Fatal Falls of Ground. COMRO Internal Report, Project Report No. 6/90, Project No. CC8S03, January.

Vervoort, A. M. J. (1990). Falls of Ground In South African Collieries During the Period 1970 – 1988. Part 3: Effect of Exploitation Method. COMRO Internal Report, Project Report No. 7/90, Project No. CC8S03, January.

Vervoort, A., (1989), Initial roof movement during development of room and pillar. International Conference of the International Association for Computer Methods and Advances in Geomechanics. Queensland, Australia, May 6 – 10.

Vervoort, A., (1989), Support design in coal mine roadways and intersections. SANGORM Symposium, “Recent advances in the design and support of underground coal mine workings”. Witbank, September.

Vervoort, A., Jack, B., Jackson, F. and Prohaska, G., (1992), Detailed underground measurements of roof deflection and bed separation. 11th International Conference on Ground Control in Mining, The university of Wollongong, N.S.W., July.

Wagner, H., (1985), Design of roofbolting patterns. COM workshop on roofbolting in collieries.

Wagner, H. and Madden, B.J., (1984), Fifteen years Experience with the Design of Coal Pillars in Shallow South African Collieries. Design and Performance of Underground Excavations. ISRM, Cambridge, 1984.

Williams, P., (1994), The development of rock bolting in UK coal mines. Mining Engineering, May.

Appendix 1

Roof Stability system – Angus Place Colliery (After Butcher)

TYPE "A" ROOF (ROOFBOLT)			
SUB CATEGORY	ROOF SUPPORT	RIB SUPPORT	RESPONSE
A1	Rows of 6x2.4 m x bar bolts, full column resin grouted, place in "W" straps or roof mesh modules.	Two 1.2 m – 2.4 m rib bolts per side. Cuttable bolts on longwall extraction side. Placed in steel and tenser mesh.	Applied where roof stabilises below 25 mm total convergence.
A2	A1 plus 4 additional 2.4 m x bar bolts placed mid row.	As per A1	Applied where roof stabilises between 25 mm and 50 mm total convergence
TYPE "B" ROOF (FLEXI BOLT SYSTEM)			
SUB CATEGORY	ROOF SUPPORT	RIB SUPPORT	RESPONSE
B1	A2 plus two 6 m fully resin grouted flexi bolts per meter Hand held systems point anchors these bolts. They are then post grouted with thixo tropic grout	A1 plus 1 additional rib bolt per side	Applied where roof stabilises between 50 mm and 100 mm total convergence. Are placed at the face where convergence rates are rapid.
B2	Per B1	Per B1	Roof stabilises between 50 mm and 100 mm. Flexi bolts placed 15-30 m behind the continuous miner, medium rate of roof convergence.
B3	Per B1	Per B1	Roof stabilises between 50 mm and 100 mm. Flexi bolts placed behind the panel advance Roof convergence rate medium to slow.
TYPE "C" ROOF (CABLE BOLT)			
SUB CATEGORY	ROOF SUPPORT	RIB SUPPORT	RESPONSE
C1	A2 support system plus two 8 m double cable bolts per meter	As per B1. However friction bolts or cementaceously grouted fibre glass bolts used where ribs are friable.	This system is placed pro-actively where roof is known to convergence greater than 100 mm on B system i.e., stress notch points, intersections, wide drivage, structural zones
C2	B1 plus two 8 m double cable bolts per metre	As per B1	Applied where roof does not stabilise below 100 mm total convergence on B1 system

TYPE "D" ROOF (EMERGENCY)			
P.U.P. (Polyurethane)	<p>Injected into shear planes and strain zones to reconsolidated very broken roof. 43 mm diameter bore holes 4 m long</p> <p>Three holes per rows, row at 2 m centres.</p>	<p>Placed n ribs where ribs friable and not suitable for bolting. 43 mm diameter bore holes 2 – 2.4 m long</p> <p>Approximately 1 hole per meter.</p>	<p>Placed where all other systems have failed or show a trend towards failure. Usually reserved to critical roads that are required to remain fully open.</p>
RIB REPLACEMENT		<p>Expanding cementaceous grout.</p> <p>3 MPa in areas of high stress, wet or need to stand for long periods.</p> <p>Less than 1 MPa where exposure time is short, area is dry and stress moderate.</p>	<p>Placed where ribs have critically deformed i.e., more than 750 mm per side, guttering has developed. Provide confinement to stop guttering and reduces roof span</p>
void, cavity filling and strata reconsolidation	<p>Expanding cementaceous grout injected into broken roof material to re-consolidate and allow re-mining.</p> <p>Combination of 3 MPa and lower strength.</p>		<p>Applied to reclaim falls in development or longwall faces where traditional methods are deemed to be a high risk.</p>
TIMBER CRIBS	<p>Usually 4 or 6 point crib using 1.8 m long timbers.</p>		<p>Applied in longwall tailgates where high stress notching is predicted with substantiate floor heave. Yielding required.</p>
CEMENTACEOUS CRIBS (fibre)	<p>Usually 4 point or full pack.</p>		<p>Placed where stiff support is required, usually roof is stronger. Also applied in area where long term stiff support is required.</p>
BAGS	<p>Bags range in diameter 0.9 m to 1.8 m. Grouts range in strength 3 MPa – 20 MPa.</p>		<p>Placed where high capacity, stiff support is required usually in longwall tailgates. Usually placed to support areas inaccessible by machinery. Grout can be pumped to 600 m.</p>
STEEL SETS	<p>Usually placed under tubular steel spiles drilled through falls.</p>		<p>Placed to recover roof falls where traditional or grout re-enforcement methods not used.</p>

APPENDIX 2

The sonic probe extensometer

1.0 Introduction

The sonic probe extensometer system is a sophisticated electronic device. It generates a pulse that travels at the speed of sound, and is able to accurately determine the distance between magnetic fields, set up by magnets which are integral to the extensometer anchors.

The cylindrical magnetic anchors are locked in place at predetermined locations in a borehole and have a plastic tube inserted through their centres. This tube acts as a guide for a flexible probe that is then inserted through the entire string of anchors. The readout unit is connected to the probe and the distances between the magnetic fields are individually displayed and manually recorded. A schematic drawing of the complete sonic probe unit and the anchors that contain the doughnut magnets is presented in Figure 1.

By taking sets of readings over a period of time any displacements occurring within the rock mass can be determined. The maximum monitoring depth is 7.5 m. However, the top anchor is usually installed at approximately 7.3 m to remain well within the reading range. Up to 21 anchors can be installed in one hole, thus very detailed information can be obtained as to the amount and location of deformation in the strata.

The readout unit is equipped with the option to measure the distances to all the anchors in the hole relative to the anchor closest to the collar of the hole, or the distances between adjacent anchors. The first option, measuring all the anchors relative to a common 'datum' anchor, was used during the monitoring programme. The reading values increase with the anchor depth into the hole making it easier to determine if a particular anchor point has inadvertently not been read.

Although the individual readings are displayed in inches down to one thousand of an inch, the overall accuracy of the system appears to be of the order of one millimetre. This figure has been derived from borehole simulation tests in the laboratory which showed that on a purely repetitive basis the majority of readings, with the exception of the occasional anomaly, taken on a set of static anchors falls within this range.

The sonic probe extensometer system is widely used in the USA, United Kingdom and Australia. They were originally introduced into South Africa approximately 10 years ago but soon became erratic and were eventually abandoned as being unreliable. A few years later it was subsequently discovered that the flexible probe has a minimum safe bending radius. If rolled up into too small a coil it is irreparably damaged. The users of the original South African instruments were unaware of this restriction at the time. The overall performance of the instrument has also been improved as a result of investigations carried out in Australia where the magnet system was changed from the original four bar magnets to a single 'doughnut' magnet in each anchor.

The instrument, being sensitive, fragile and expensive, needs to be treated with care. In the event of damage it usually needs to be sent to Australia for repair. There is a company based in Wollongong who has developed expertise in sonic probe repairs. They are prepared to attempt repairs that the manufacturers will not undertake.

If the user of an instrument does not have confidence in an instrument the results obtained will always be suspect and consequently of little real value. One of the primary objectives when acquiring any new instrument is therefore to build up confidence in its abilities or to identify any shortcomings. To this end many controlled experiments with the sonic probe extensometer have been carried out.

2.0 Processing and presentation of results

A customised computer program for processing the data and producing graphs was written by CSIR - Miningtek. A maximum of three sets of readings taken from up to 21 anchor positions can be input into the program. The output options include two different formats of time/displacement graphs as well as velocity and acceleration graphs.

In order to check the program for any irregularities, the outputs were compared against hand calculated values and graphs.

The sonic probe measures the distance to each anchor relative to the reference anchor, which is the anchor closest to the collar of the hole. However, for graphical interpretation the computer program assumes the top anchor to be static and makes it the reference point, and then calculates the position of all the other anchors in the string relative to it.

3.0 Evaluation of the sonic probe system

A calibration/test rig was developed and installed at Miningtek. A 50 mm diameter 7.3 m vertical perspex tube attached to a wall inside the building is used to simulate a borehole drilled into the roof. At the collar end of the hole a short length of tube, long enough to accommodate two anchors, has been joined to the longer tube by means of a thread. By rotating this short tube the bottom two anchors can be moved up or down specific distances in increments as small as 0.1 mm. A thermometer attached to the test rig is used to record the temperature when a set of readings is taken.

A series of tests were carried out to determine reliability, accuracy and the effects of temperature, magnetic interference and slab loss. Cross probe calibrations were done to investigate the relationship between the different sets of results obtained when using different sonic probes.

For viewing clarity the graphical outputs from the sonic probe readings have an exaggerated vertical displacement scale. As a result any 'anomalous' readings tend to be over emphasised. For purposes of anchor identification a convention is set in which anchor number one is always the closest anchor to the bottom or collar of the borehole.

3.1 Reliability

Sets of readings have been taken over a number of years to establish the reliability and repeatability of readings taken on those anchors in the test rig that could not be moved. The results show the majority of readings to be within a 1.0 mm band for any given temperature.

3.2 Temperature

During the reliability tests it became apparent that there is a linear drift over the 7.3 m length of about 1.0 mm for every one 1 °C change in temperature. A typical temperature drift graph is presented in Figure 2. This in itself is of no real consequence to readings taken underground as the ambient temperature within the rock mass varies very little.

It is however an important consideration that has to be taken into account when checking the probe calibration and carrying out reliability tests. From the test rig database it is possible to produce a temperature compensating calibration curve for each probe.

3.3 Accuracy

The bottom two anchors in the test rig were lowered by precise increments of 0.1 mm and readings were taken at the various positions. This test was repeated four times. The results presented in Figure 3 showed the probe to be capable of measuring the overall displacements to within 0.1 mm of the physical movements.

There also appears to be time/usage accuracy that became apparent as it developed in the longer term over a period of months and years. Two sets of readings taken four months apart in the test rig, both at 22 °C, are plotted in Figure 4. The additional drift in the readings also appears to be more or less linear and can therefore be relatively easily compensated for. This type of affect emphasises the need for regular calibration readings to be taken in a test rig.

The same affect can be seen in Figure 5 between two sets of underground readings taken nine months apart. Although there is an obvious drift in the readings, the profiles are nearly identical. From the lack of change in the profiles, the long term stability of this particular roof and its support, and the repeatability/accuracy of the sonic probe in the underground environment is apparent.

In the physical construction of the sonic probe, an intricate part is a very fine wire that runs through a small alloy tube in the centre of the probe. This wire is kept under tension by a spring. The linear nature of both the temperature and time/usage drifts suggests that it may be linked to, and affected by the tension changes in this wire.

3.4 External magnetic interference

Interference from an external magnetic source in the form of another 'doughnut' magnet held on its side up against the outside of the Perspex tube appeared to have a negligible effect. As the magnet was moved towards and away from an anchor, while it was being monitored, the reading changed by a total of 20 units, 10 units either side of the original reading; 20 units represents 0.5 mm.

3.5 Internal magnetic interference

When two anchors inside the borehole are positioned too close to one another, the probe is unable to detect both of them. This results in a single totally unreliable reading or a random oscillation between the two anchors where one is recognised and the other ignored. This occurs when the anchor spacing is closer than 170 mm. To avoid this becoming a problem in the underground monitoring situation, anchors are not installed closer than 250 mm apart.

3.6 Cross probe calibration

By using two different probes and readout units to read the same anchor installation at the same temperature, a cross probe calibration curve can be produced, an example of which is presented in Figure 6.

Each probe and its readout unit has its own characteristics and will give subtly different readings when measuring the same finite distances. These variations can be larger than the small amounts of displacements being measured. This in no way effects either probe's ability to detect small movements but rather introduces a compatibility problem.

In the event of a probe suffering damage or breakdown during a monitoring programme, a backup probe that has a suitable cross calibration curve could be used to continue the monitoring without a loss in the continuity of readings.

3.7 Slab loss

Although the instrument uses the anchor closest to the collar of the hole as its datum point, it is possible to lose one or more anchors as a result of sidewall spalling or a roof fall and still continue to monitor the remaining anchors without a loss of continuity.

To establish the practicalities involved, a test was carried out in the test rig. The graphical results and test procedure, as well as problems encountered and subsequent actions taken, are presented in Figure 7.

Apart from the problems experienced due to the initial lack of clearance between the anchor guide holes and the liner tube, the test was a complete success. The removal of the two bottom anchors to simulate their loss due to a roof fall or sidewall spalling was counteracted by mathematical manipulation. The original datum readings were recalculated using the third anchor from the bottom as the datum anchor. This new set of datum readings was then copied into a new file. All subsequent sets of readings were recorded in the new file and processed in the usual way. There was no loss of continuity when the graphical outputs of the new file were compared to the graphical results from the original file, prior to the loss of the two anchors.

3.8 Confidence

An instrument is usually installed in an area where deformation is expected to occur. If the results indicate that no movement occurred, doubts about the reliability of the instrument are raised. This scenario occurred more than once during the underground roof behaviour field trials. The sonic probe was immediately subjected to a series of tests in the test rig, which indicated that it was functioning perfectly.

It is imperative that the evaluation of the sonic probe continues under a variety of conditions such that confidence in the applicability of this potentially useful instrument is thoroughly established and maintained. Only then will we be in a position to accept the majority of underground monitoring results as a true reflection of what is occurring. The shift in emphasis should then be made to formulating possible explanations regarding roof behaviour that at times appear to fall outside our accepted and sometimes preconceived ideas.

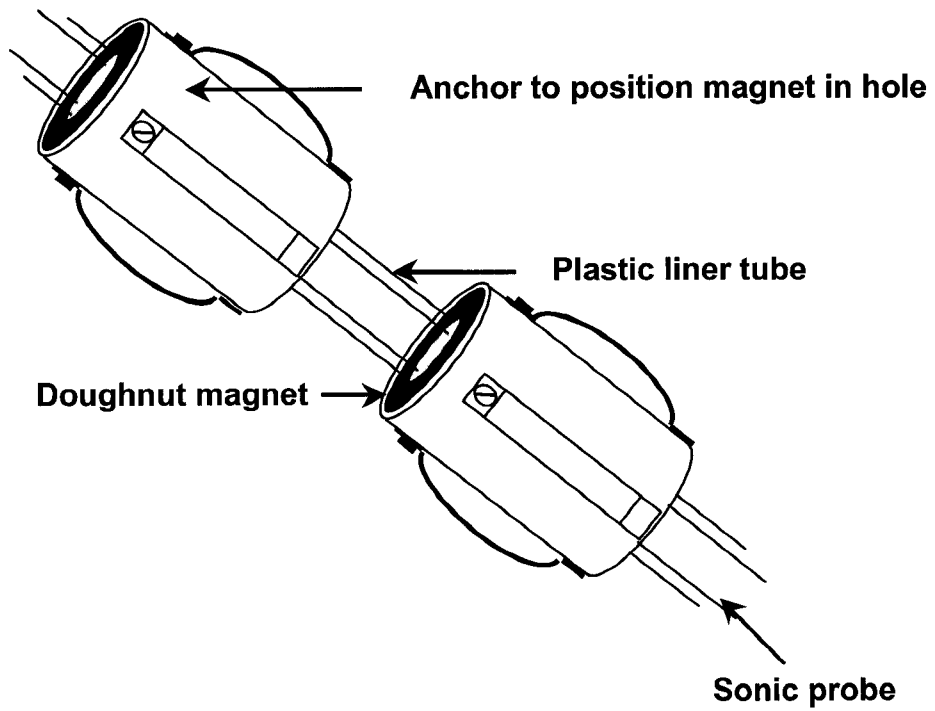
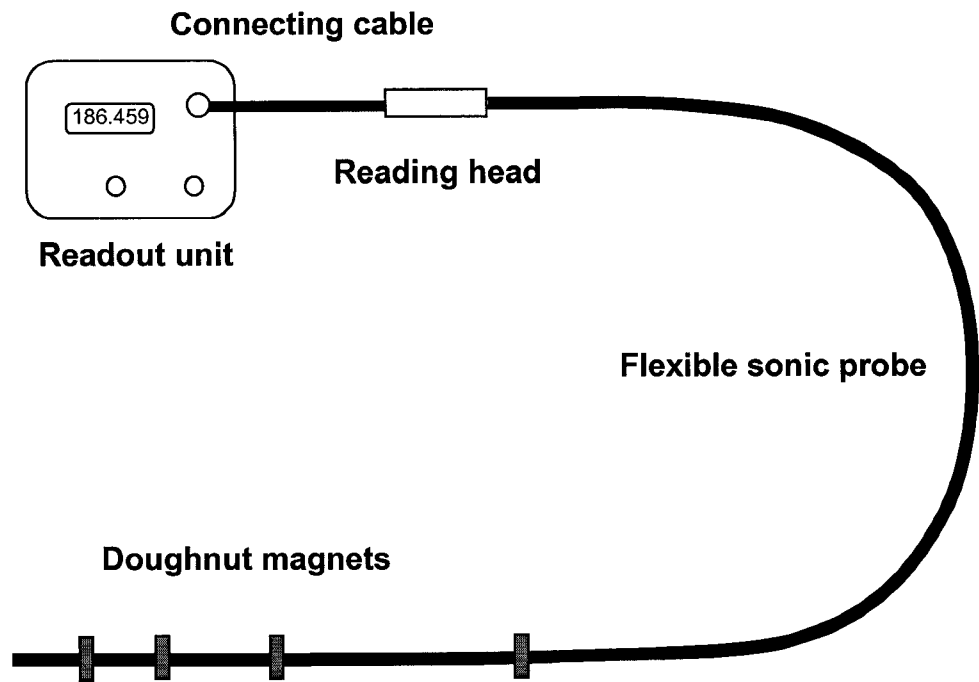

Figure 1. Schematic drawing of the sonic probe and magnetic anchors

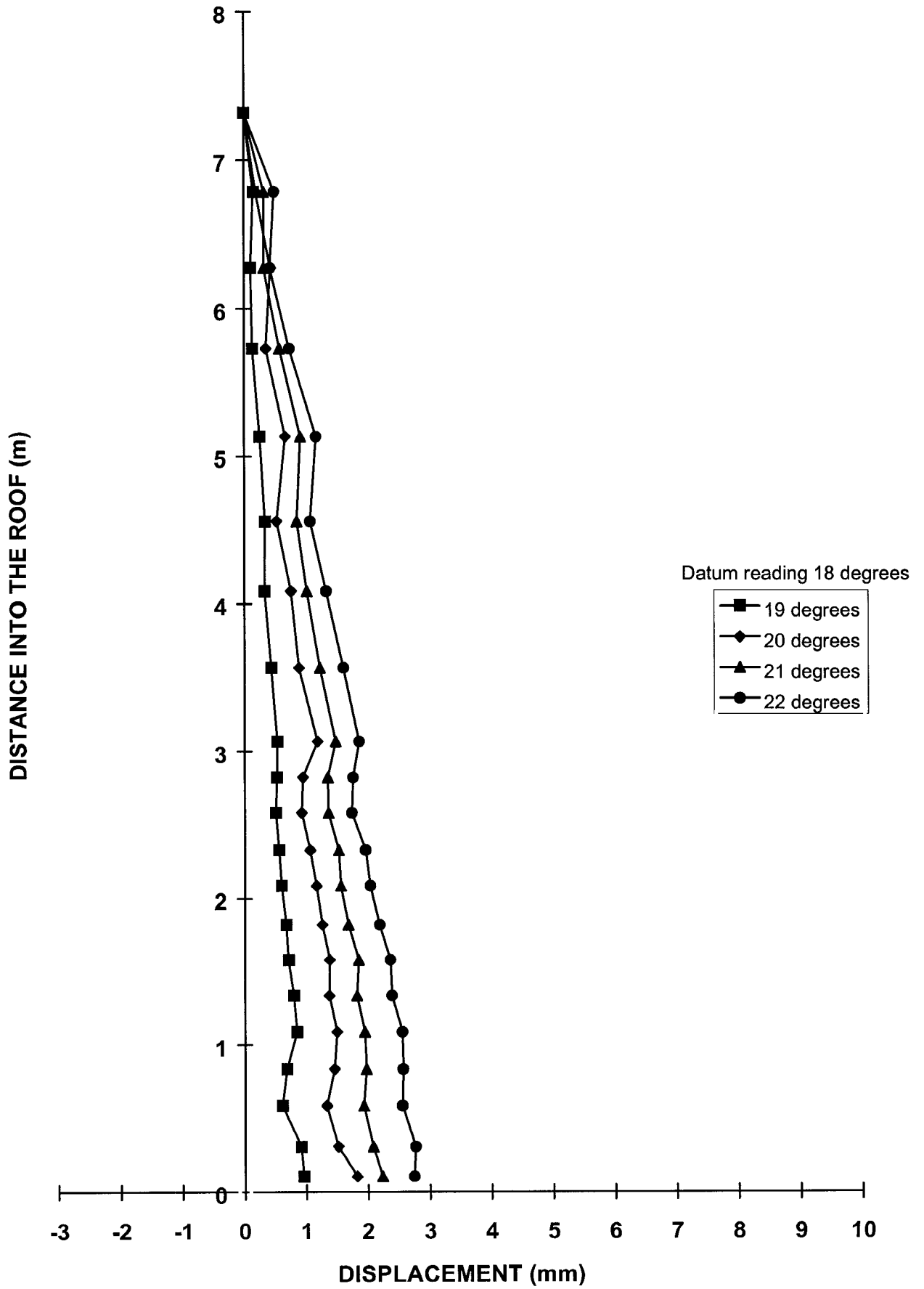

Figure 2. Sonic probe temperature drift

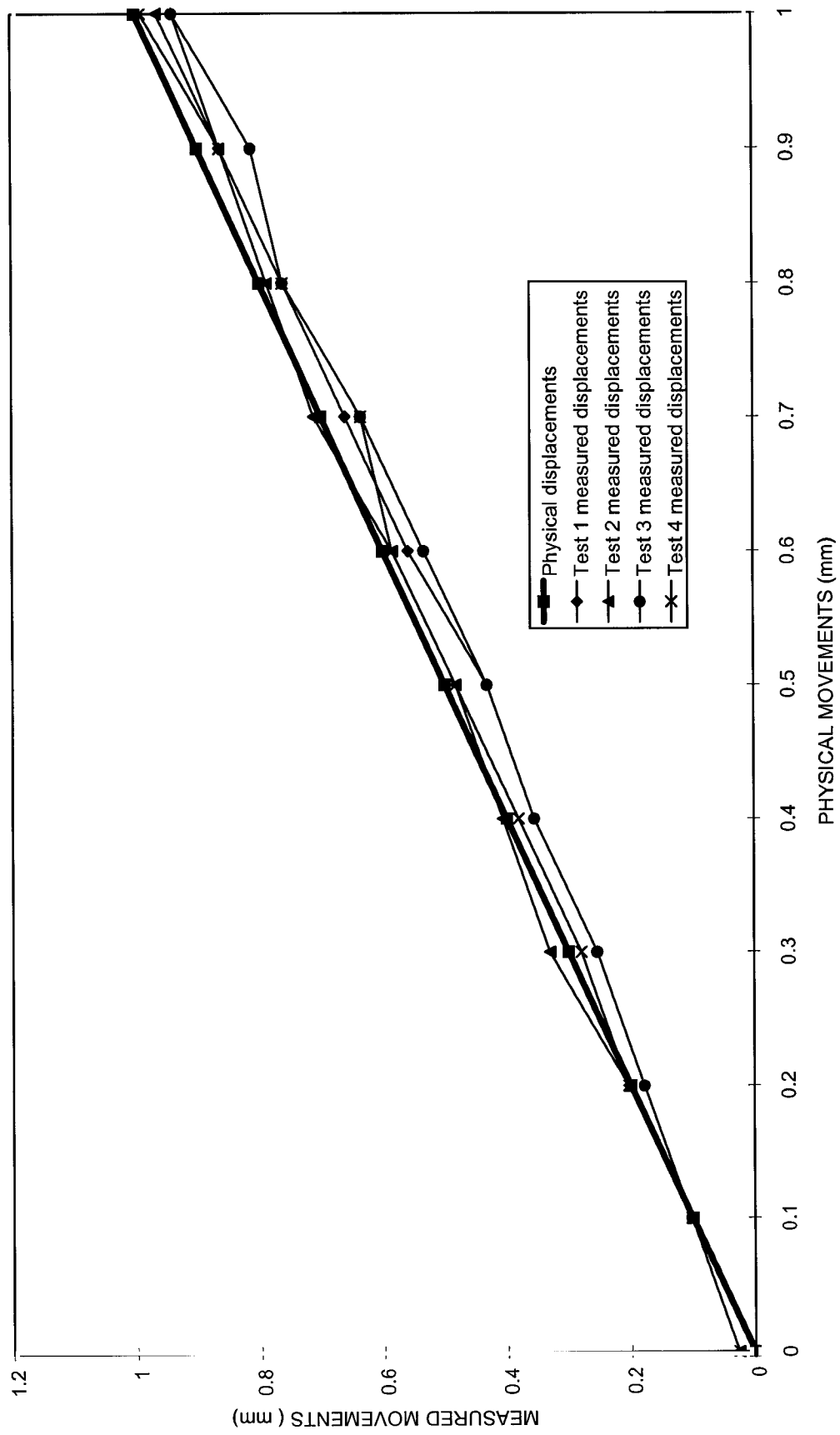

Figure 3. Comparison of measured and physical displacements

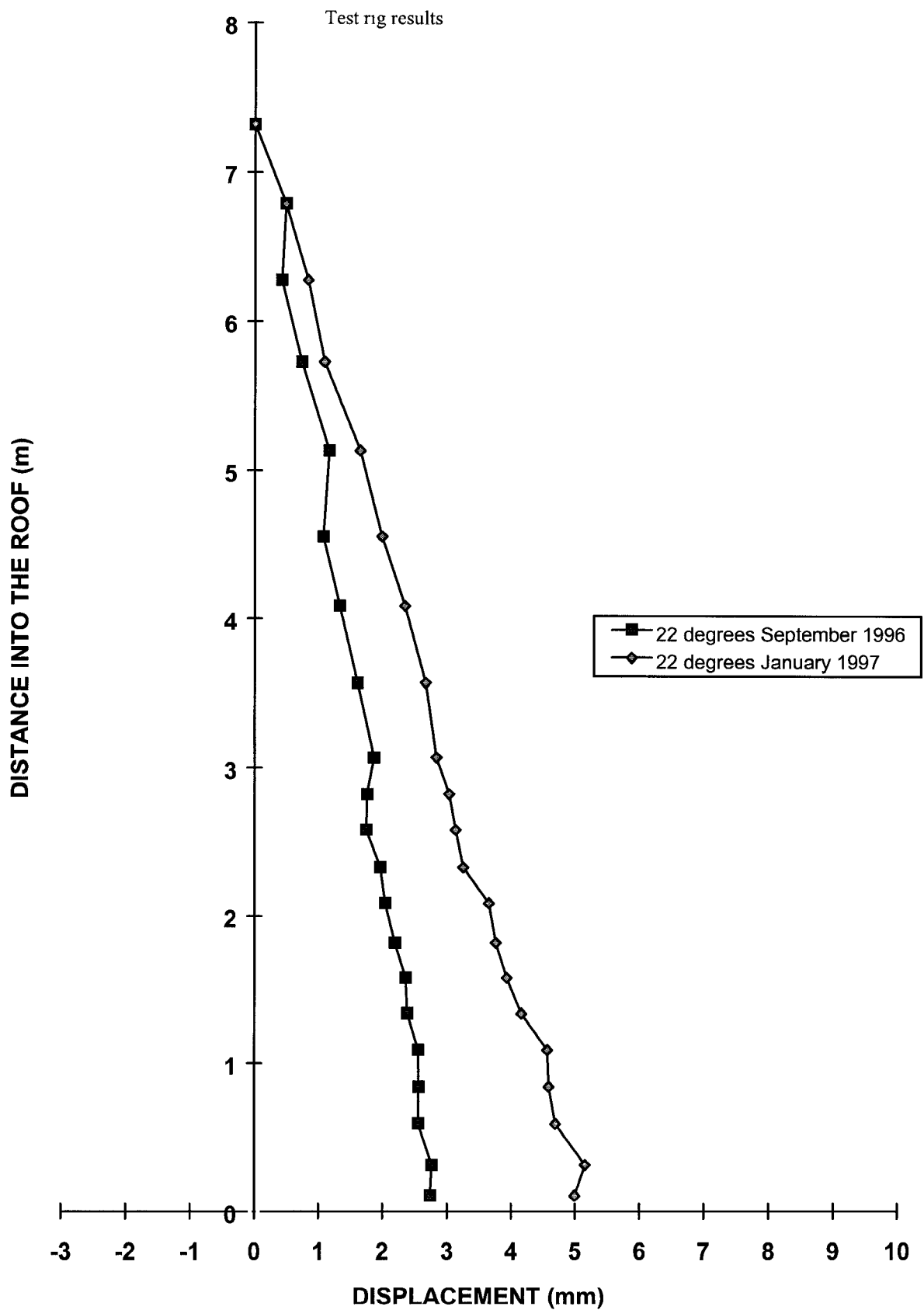

Figure 4. Sonic probe reading drift over four months

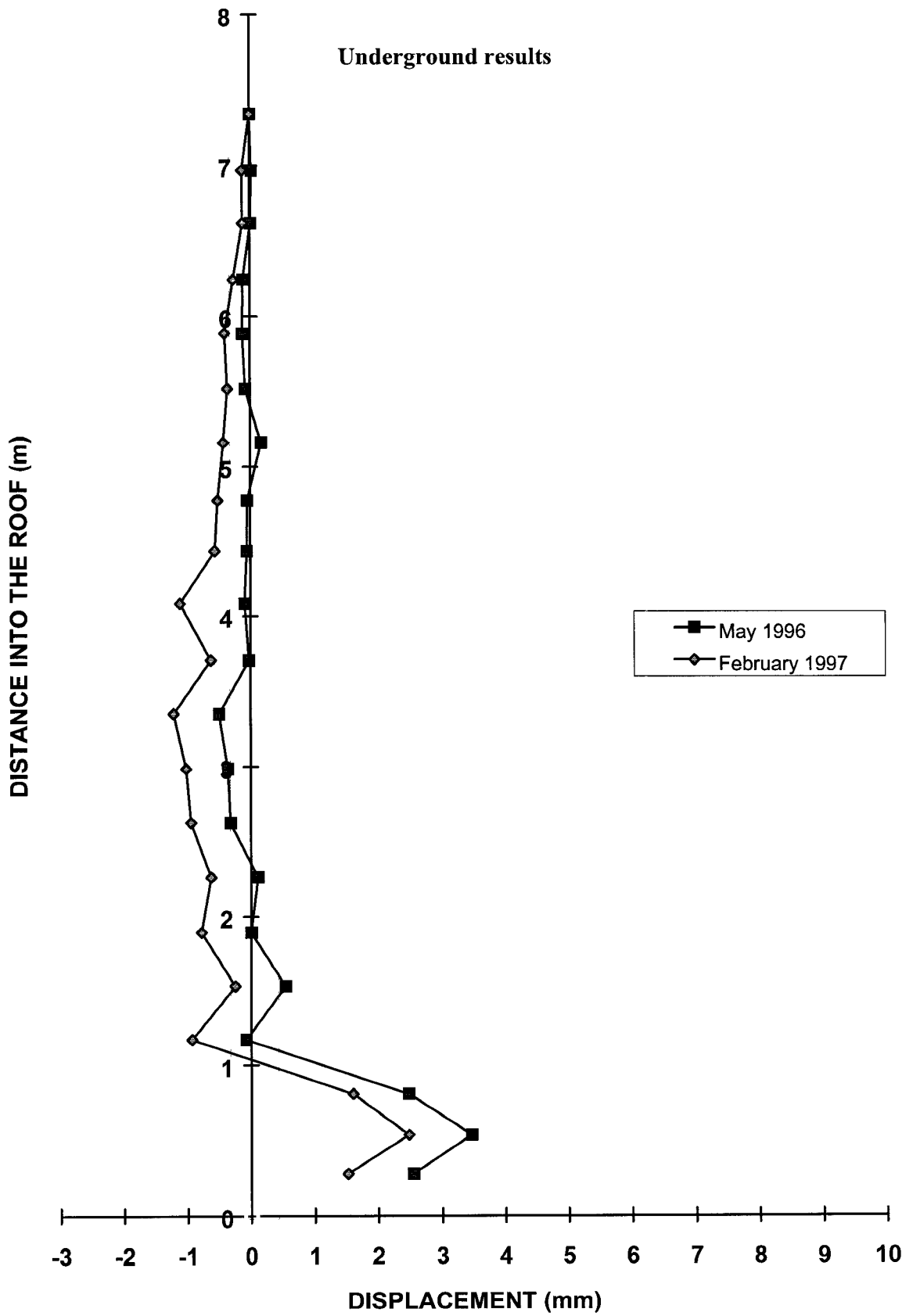

Figure 5. Sonic probe reading drift over nine months

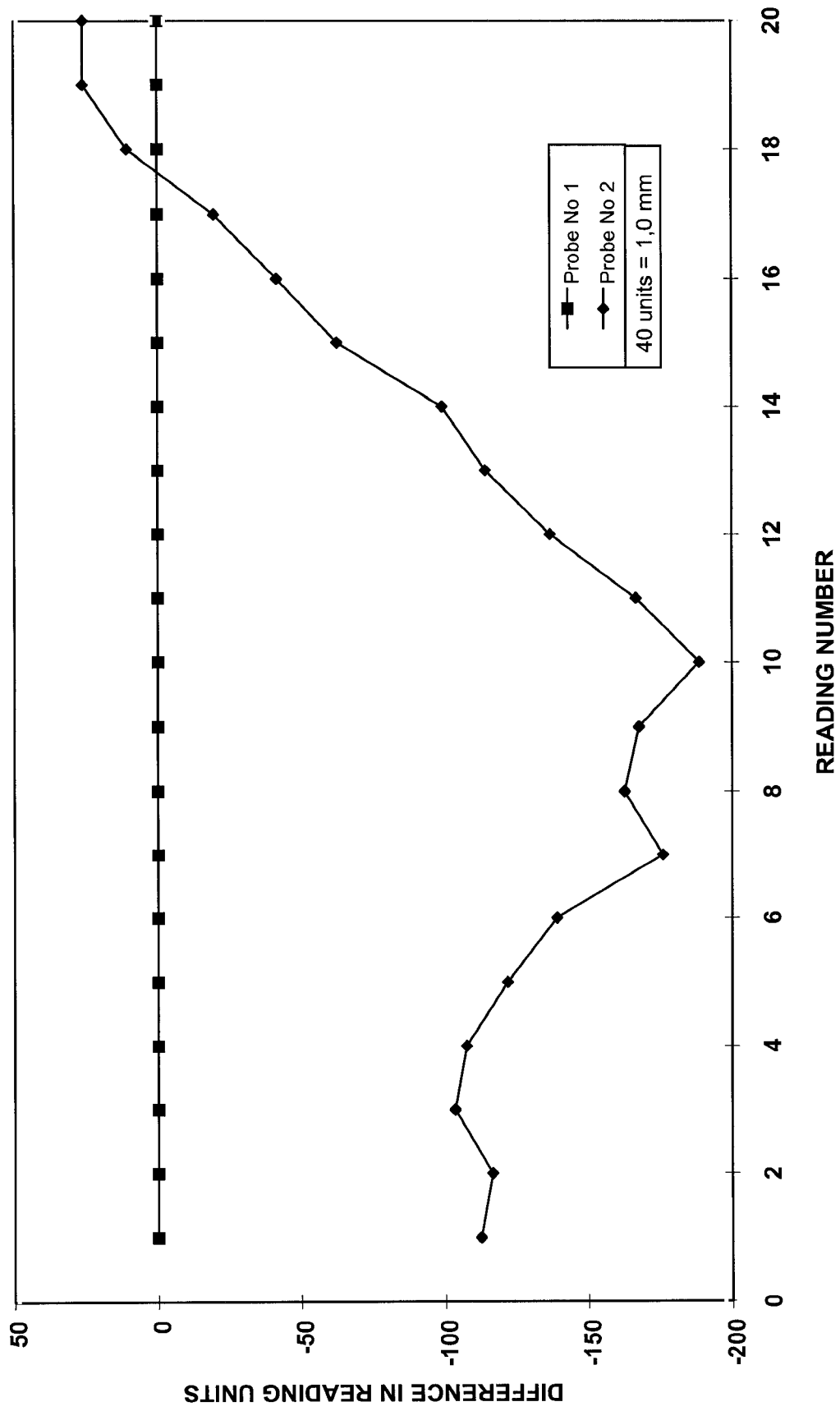

Figure 6. Cross calibration curve of two sonic probes

Procedure

After taking an original set of readings, the bottom two anchors were lowered by 4.0 mm and a further set of readings taken. Both anchors were then removed by unscrewing the short section of pipe containing them and a further set of readings were taken. The pipe containing the bottom two anchors was then replaced on the test rig and screwed up to the original 'zero' position and a final set of readings taken.

Problems experienced

At the time, the test rig was equipped with a set of prototype anchors. The liner tube and the guide hole in the anchors were a relatively tight fit which has since been rectified. Screwing the bottom pipe off withdrew the liner pipe by about 50 mm which was not noticed at the time.

When the pipe was replaced the protruding liner tube had to be pushed slowly back up into the anchor column. Some of the anchors could have moved during this insertion. It is also possible that the bottom anchor may have fouled on the liner tube as it was being screwed downwards for the 4.0 mm displacement reading. This could have moved the anchor upwards in the pipe (relative to the other anchors) and account for the "kickback" shown on the graph.

Since 'kickbacks' had occurred in the underground monitoring programme it was important that the reason for this phenomenon be established. In the final analysis of the underground monitoring programme it became apparent that the "kickbacks" were real. They were only recorded where the drill and blast mining method was used and appeared to be as a result of the closure of pre-existing openings.

Action taken

The test rig was re-equipped with the new anchors to reduce the liner tube / anchor friction. The bottom two anchors have been installed a fixed distance apart and cannot move relative to each other. Apart from during this particular test, no other kickback has been recorded in the test rig.

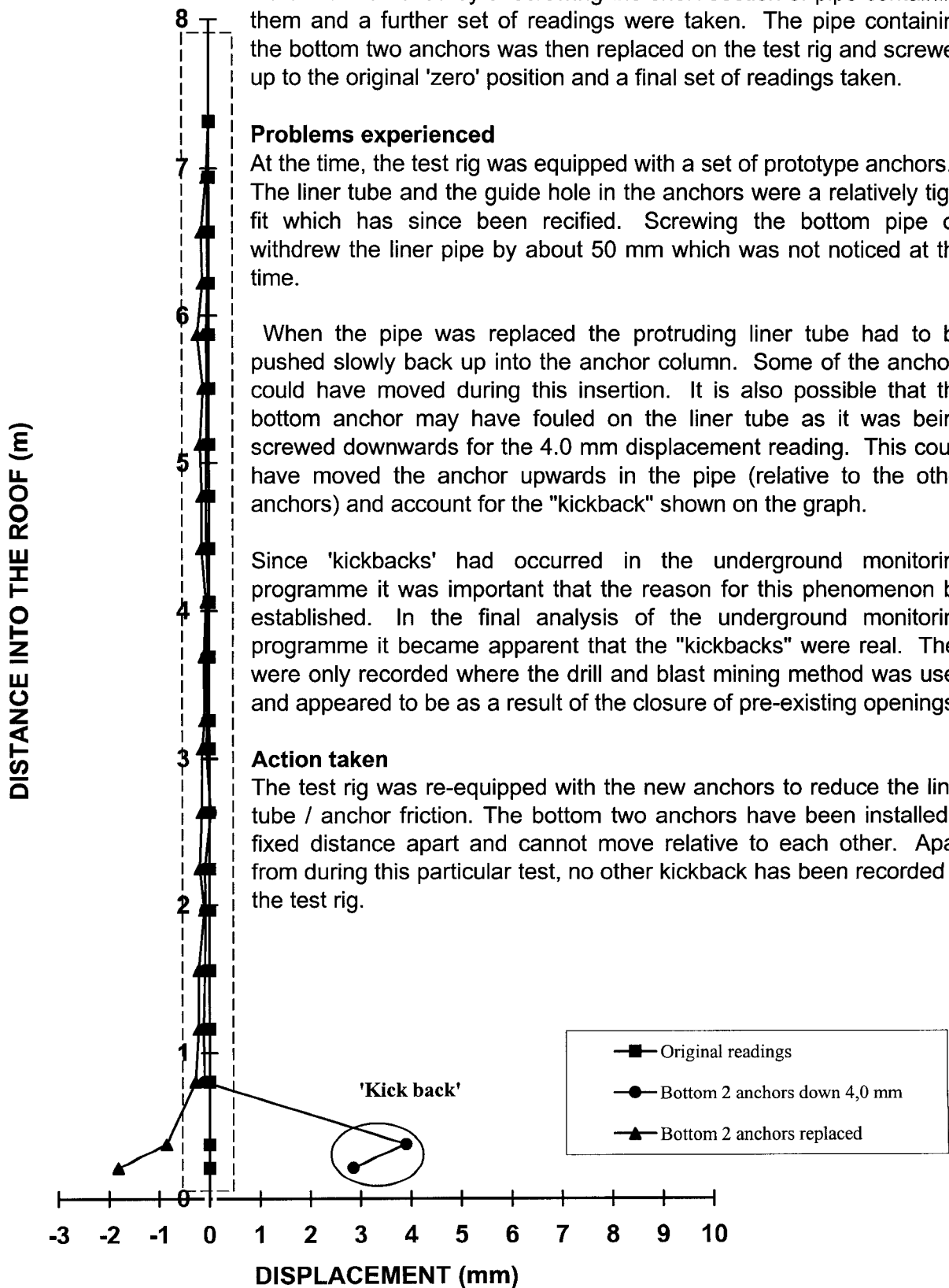

Figure 7. Anchor loss due to rock fall test

APPENDIX 3

An introduction to the interpretation of sonic probe graphs

1.0 General layout

The vertical movement, or displacement, of the magnetic anchors installed in a borehole drilled into the roof are shown relative to the anchor at the top of the hole which is assumed to be stable. The maximum height at which the top anchor is usually installed is about 7.3 m in from the collar of the hole.

2.0 The accepted accuracy band

When viewing the graph the vertical (distance into the roof) axis could be considered to be a section cut through the hole exposing all the anchors at their installation elevations. There is a rectangular dash outlined box around this axis that extends laterally from -0.5 mm to +0.5 mm on the horizontal (displacement) scale. This box, labelled as the “accepted accuracy band”, is included to place any displacements that are recorded, into perspective. The accepted accuracy band, along with a set of original readings and an explanation, are presented in Figure 1.

3.0 Identification of typical roof displacements

In the monitoring of roof behaviour there are usually two scenarios that are encountered. One being the opening of parting planes on a macro scale creating relatively thick beams. The other, in comparison, occurs more on a micro scale with delamination or unravelling of the immediate roof due to the effects of gravity and bending of thin layers of material that is interlaminated or fractured.

An idealised graph, representative of the more common immediate roof relaxation and “unravelling”, is presented in Figure 2. The typical stepped profile associated with the deflection of more massive beams is shown in Figure 3. These different mechanisms need not necessarily occur in isolation. Both forms of roof displacement could be encountered in a single monitoring hole.

4.0 Displacement direction

By the very nature of the mechanics involved, the central portion of the roof strata spanning any excavation is subject to gravity and tensile elongation in the vertical plane. In areas where high horizontal stress regimes exist, these vertical gravitational displacements are compounded by the buckling of strata beams, particularly near the roof skin. It is for this reason that, in the ideal situation all the displacements recorded by the magnetic anchors should be positive in nature, i.e. move to the right of the vertical axis. Any apparent negative displacements, particularly outside the 1.0 mm wide accuracy band, should be treated with caution.

A phenomenon that initially occurred in the immediate vicinity of the roof skin in approximately 30 per cent of the monitoring sites is the so called “kickback”, a typical example of which is presented in Figure 4. When first encountered, this phenomenon of anchors apparently moving towards each other, was thought to be an anomaly introduced as a result of the mathematics involved in transposing the fixed reference point to the top anchor in the hole.

The sonic probe measures the distance to each anchor relative to the reference anchor, which is the anchor closest to the collar of the hole. However, for the graphical interpretation the computer program assumes the top anchor to be static, makes it the reference point, and calculates the position of all the other anchors in the string relative to it. If there is a drift in the string of readings, similar to tape measurements taken where the zero does not exactly coincide with the reference point, the measurement to each anchor will be offset by a similar value. Because the offset value is common to all the anchor measurements, it is eliminated in all but one of the re-positioning calculations. The exception is the anchor closest to the collar of the hole. In this case, any offset value, which may be included in the measurement, between the

first and last anchors, cannot be eliminated in a calculation and is assumed to be a true and accurate measurement.

As the size of the database increased and more examples of kickbacks began to emerge, it became apparent that kickbacks were only recorded in drill and blast sections. At one colliery in particular, kickbacks were evident some distance into the roof, not only, or necessarily, in the immediate vicinity of the roof skin. This effectively ruled out the mathematical anomaly in these cases. It also eliminated another possible explanation being the shrinkage of certain soft roof strata types through drying out when exposed to ventilation. The most feasible explanation was the presence of pre-existing open partings in the roof prior to the installation of the support and instrumentation. The later closure of these partings as beam separation and deflection migrate higher into the roof would result in anchors moving towards each other. This relative movement would manifest itself as a kickback in the sonic probe graph.

“Kickbacks” have also been recorded in Australian collieries close to the roof skin. The physical values are similar to those experienced locally. However, in Australia, in most cases where the sonic probe is used, displacements of tens to hundreds of millimetres are measured, an order of magnitude higher than in South Africa. The magnitude of the displacements and having graphs plotted at these larger scales tend to overshadow any kickbacks and little attention is paid to them. The Australian computer program uses a similar mathematical process to CSIR-Miningtek to convert the measurements relative to a reference anchor at the top of the hole.

5.0 Anomalies

In common with most other forms of instrumentation, the sonic probe does on occasion produce anomalous readings. In the situation where there is the possibility of unconventional but ‘real’ displacements taking place alongside anomalous readings, it becomes increasingly difficult to differentiate between the two. However, as the size of the database increases and interpretation experience grows, it should be possible to introduce a few simple criteria checks to assist in identifying anomalous readings.

Some of the more typical examples of anomalous readings are discussed in Figure 5. Although, to the untrained eye their appearance can cause alarm, closer investigation usually confirms them to be what they are, anomalies. The apparent displacement indicated by an anomalous reading or readings is usually not substantiated by the anchors in the string above or below the anchor or anchors in question.

6.0 Interpretation of typical underground results

All the above mentioned Figures 1 to 5 are idealised graphs produced specifically to illustrate the points under discussion. In contrast, Figure 6 was compiled from five sets of readings, the original plus four others, taken underground. This particular exercise involved the monitoring of an intersection from the point where it was a development end, up until the other three roadways had been developed away from it up to a distance of 48 m.

Here the major displacements occur within about 1.8 m of the immediate roof. The total displacement between the 1.8 m elevation and the roof skin is about 5.5 mm. From the readings taken on day three the “unravelling “ of the immediate roof strata can be observed as the largest displacement is between the first and second anchors in from the collar of the hole. By day eight there is a displacement of similar magnitude between the second and third anchors as the delamination migrates higher into the roof, at the same time partially closing the open fractures between the first and second anchors.

As explained on the graph, the roof displacement had become static or stabilised by the time the face had advanced to the 28 m position.

The presence of “anomalous” readings are also fairly obvious close to the 4.0 m elevation with a border line case at 6.5 m.

From the slight wandering of individual points and drifting of similarly shaped profiles, particularly in the lower section of the hole, it can be appreciated how this information was used in the initial calibration of the instrument to help establish the “Accepted accuracy band”.

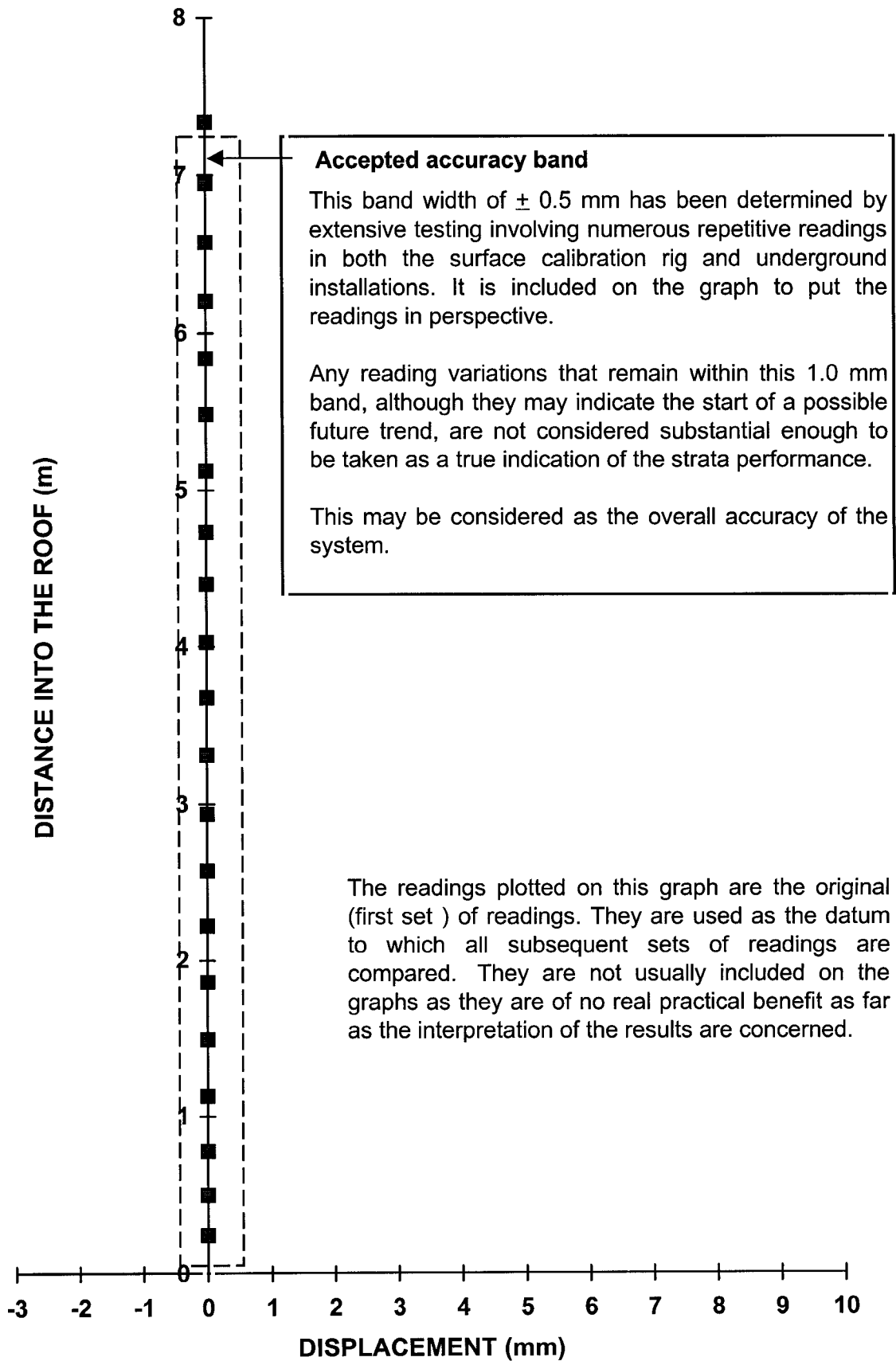

Figure 1. The accepted accuracy band

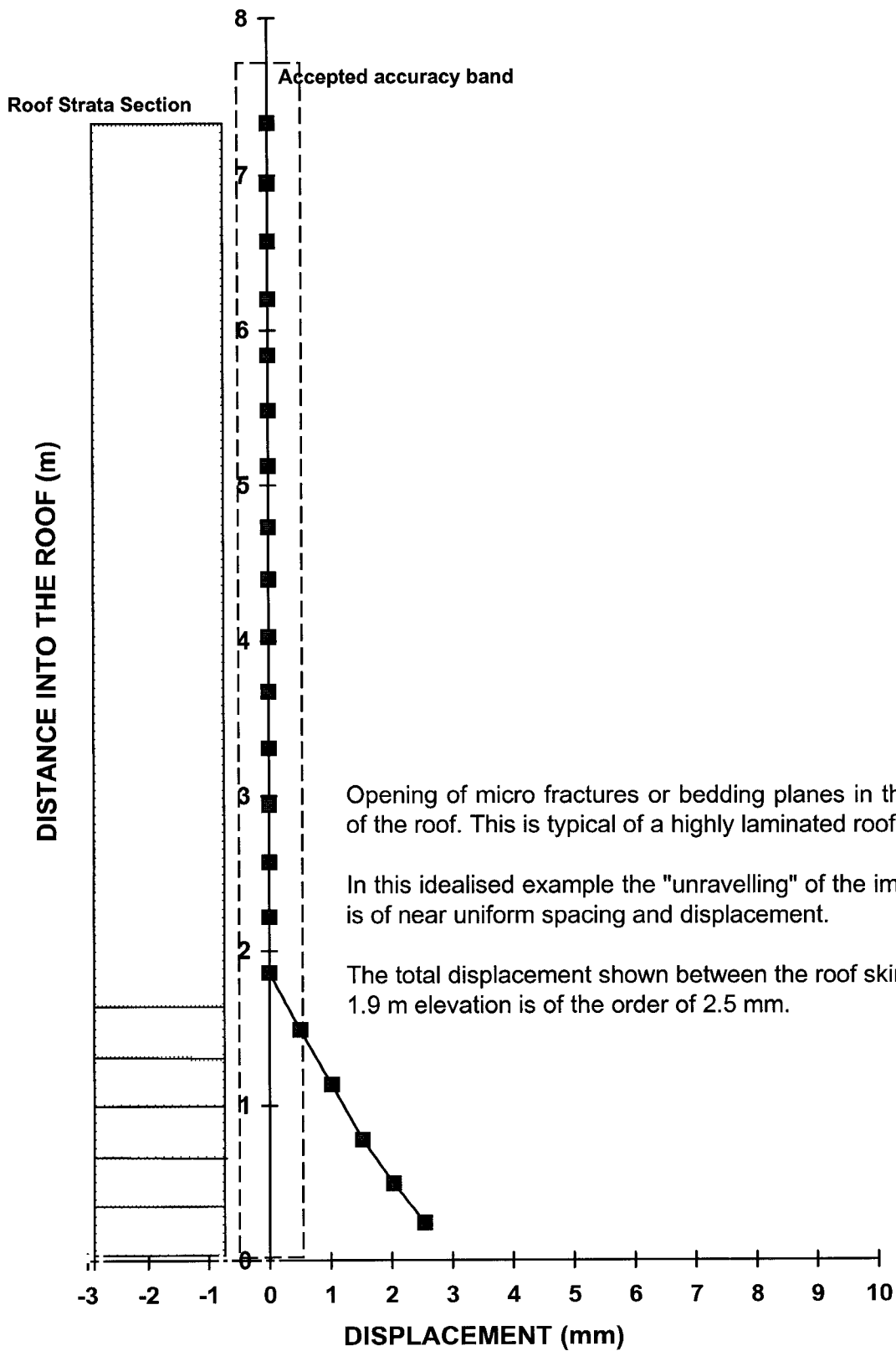

Figure 2. Unravelling of a laminated roof

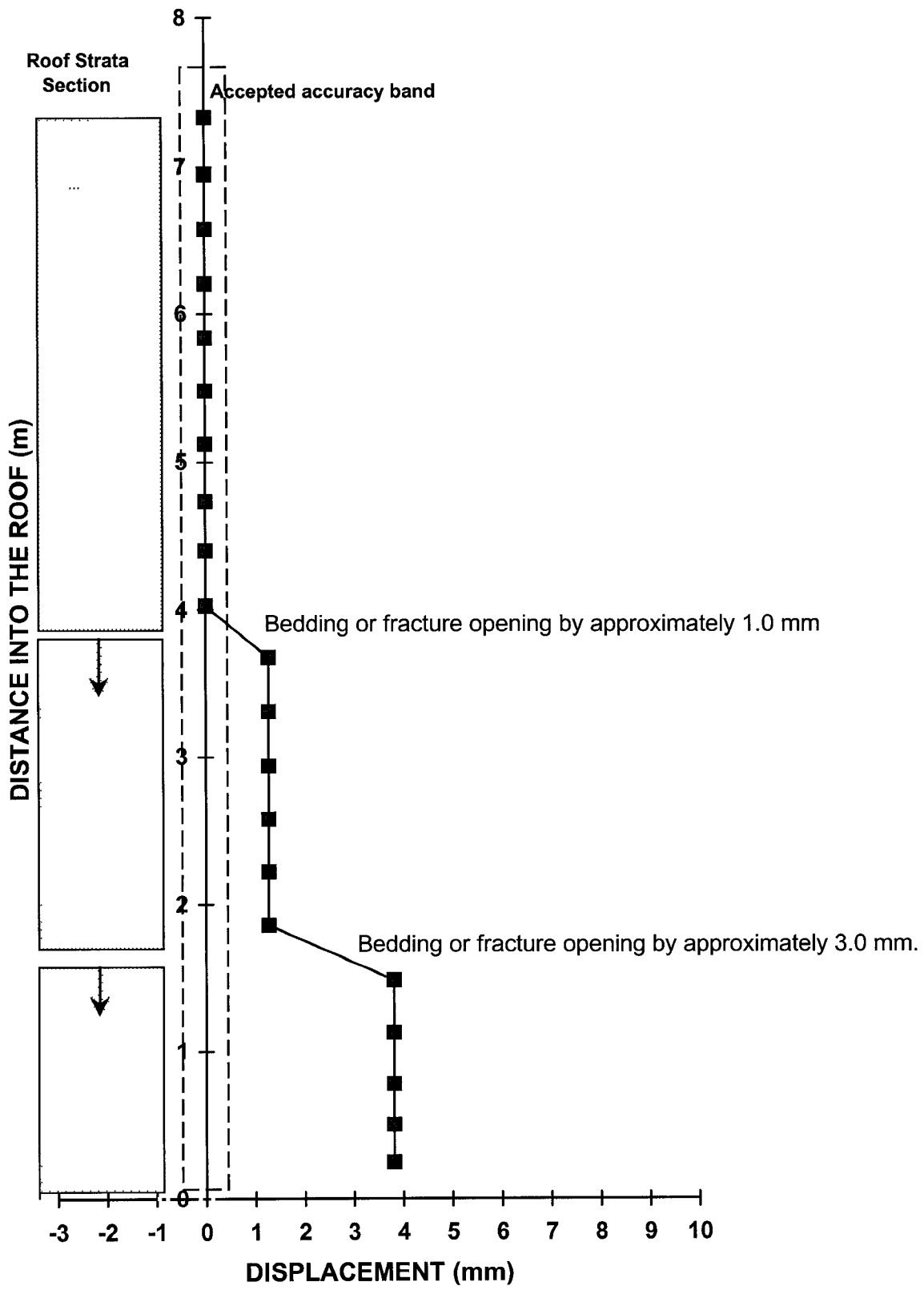

Figure 3. Parting planes opening

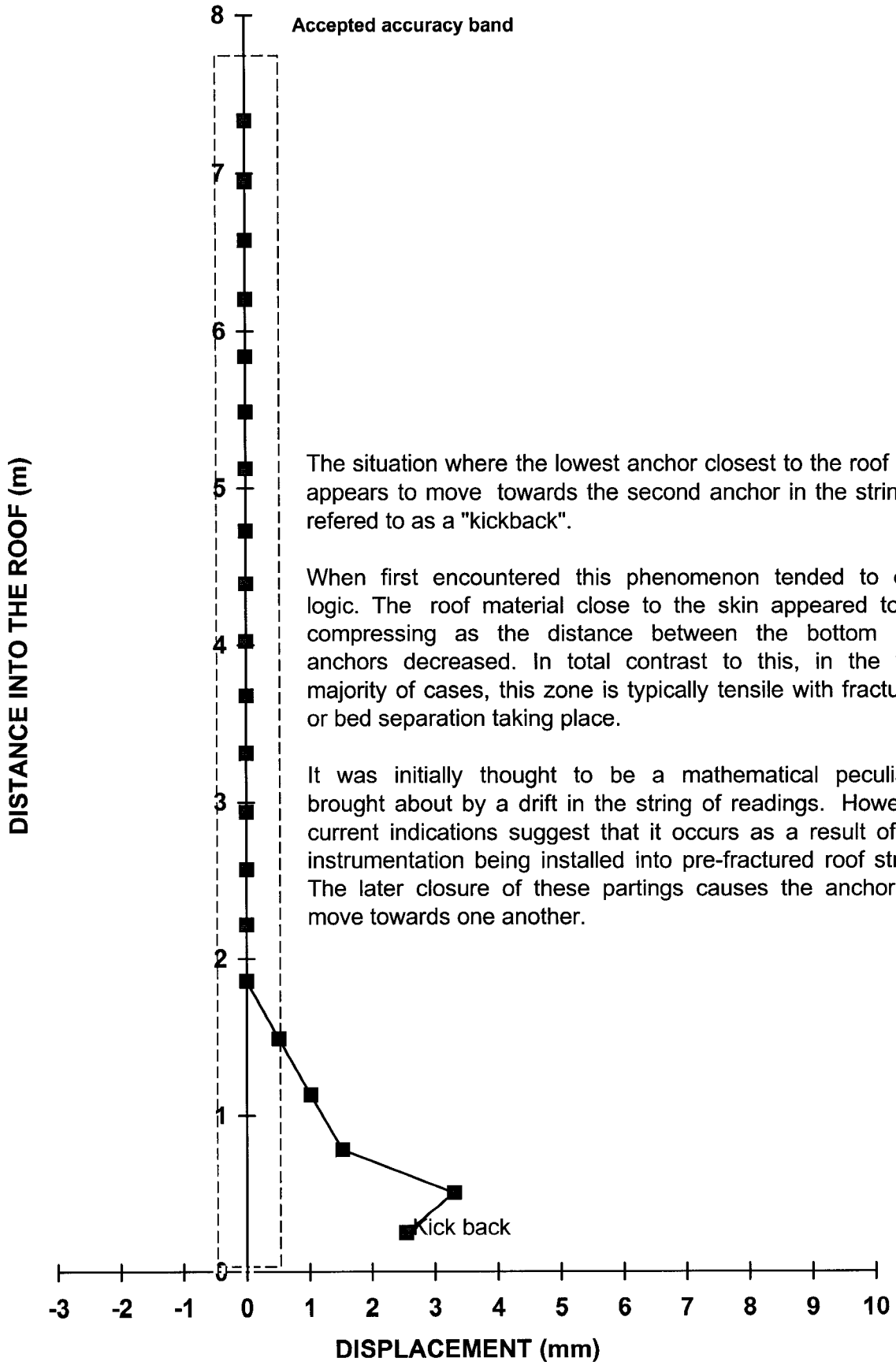

Figure 4. The kickback

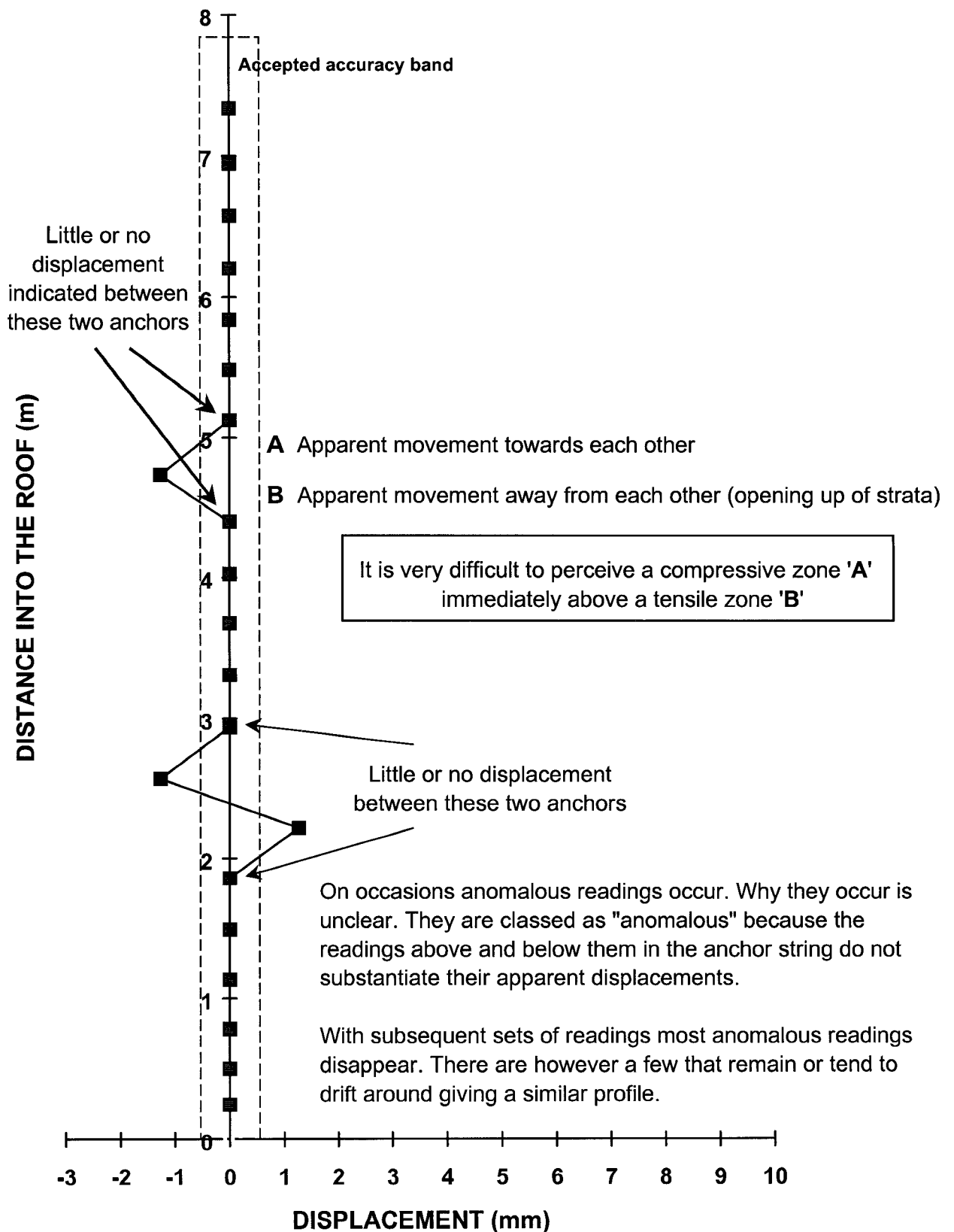
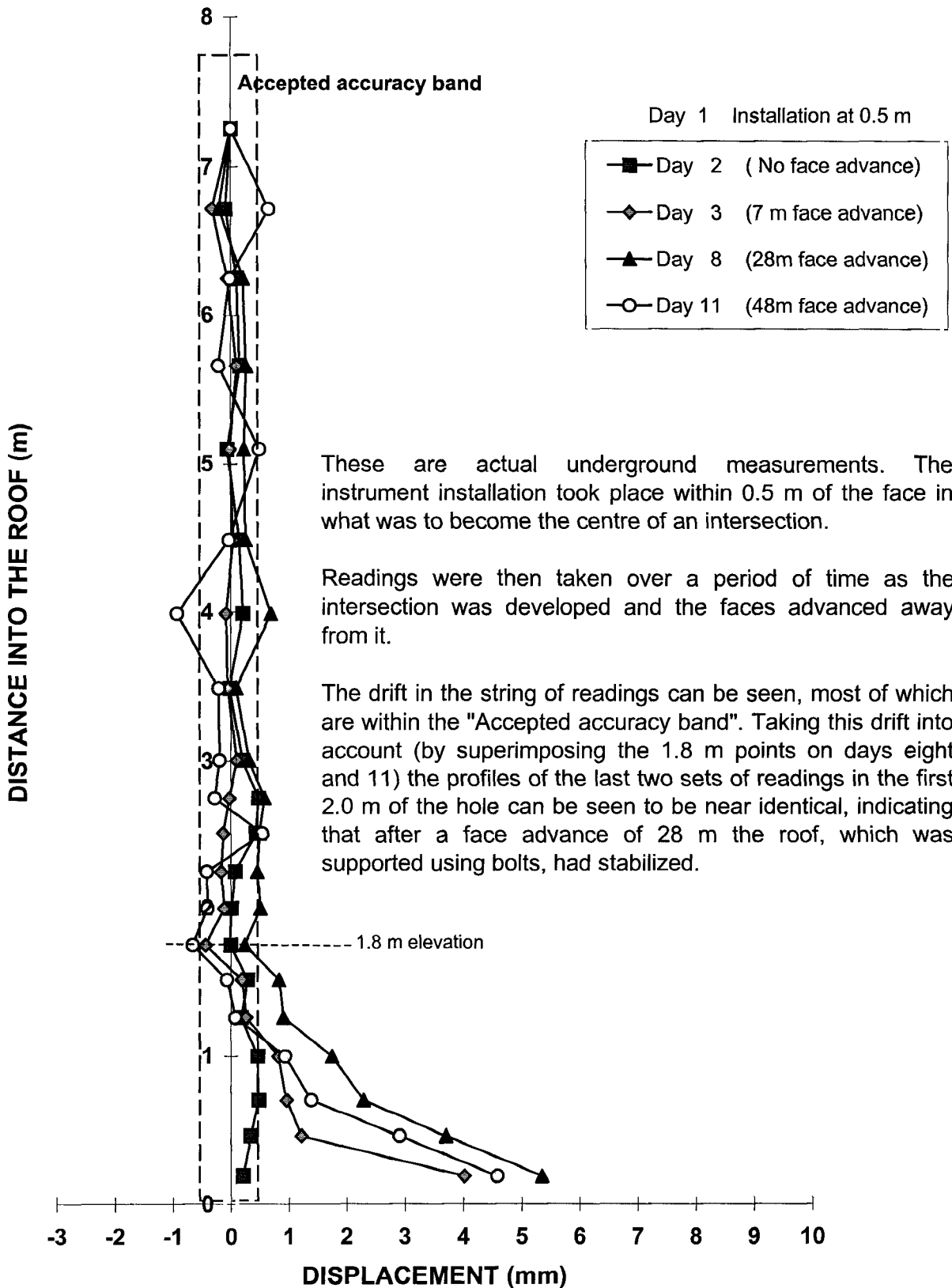

Figure 5. Anomalous readings



These are actual underground measurements. The instrument installation took place within 0.5 m of the face in what was to become the centre of an intersection.

Readings were then taken over a period of time as the intersection was developed and the faces advanced away from it.

The drift in the string of readings can be seen, most of which are within the "Accepted accuracy band". Taking this drift into account (by superimposing the 1.8 m points on days eight and 11) the profiles of the last two sets of readings in the first 2.0 m of the hole can be seen to be near identical, indicating that after a face advance of 28 m the roof, which was supported using bolts, had stabilized.

Figure 6. Development of an intersection