

The 5th International Conference on Electrical Engineering and Green Energy, CEEGE 2022,  
8–11 June, Berlin, Germany

# Efficient wireless power transfer via self-resonant Conformal Strongly Coupled Magnetic Resonance for wireless sensor networks

Molefi J. Makhetha<sup>a,\*</sup>, Elisha D. Markus<sup>a</sup>, Adnan M. Abu-Mahfouz<sup>b</sup>

<sup>a</sup> *Electrical, Electronic and Computer Engineering, Central University of Technology, Free State, 20 Pres. Brand Street, Private Bag X20539, South Africa*

<sup>b</sup> *NextGen Enterprises and Institutions, Council for Scientific and Industrial Research, Pretoria, South Africa*

Received 17 August 2022; accepted 29 August 2022

Available online xxxx

## Abstract

This paper presents a wireless power transfer (WPT) technique based on self-resonant Conformal Strongly Coupled Magnetic Resonance (CSCMR) model. The proposed model is compared to a capacitor-loaded mode in terms of their transmission efficiency through simulations. The simulations are run using MATLAB, High Frequency Structure Simulator (HFSS) and OptiSLang. Results confirm that a self-resonant CSCMR-WPT performs better than a capacitor loaded model. To achieve an efficient WPT, a lot of resources may be required for the model which necessitates a high computational time. Hence, compared to using only a 3D simulation software as reported in many literature, a co-simulation is performed between HFSS and OptiSLang to reduce computational resources. Furthermore, using MATLAB to conceptualise the CSCMR resonators gives better guidance and satisfactory results which shortens the simulation times by providing estimated WPT system parameters for an optimal model. The study concludes that, using the co-simulation has reduced computational time by 93% compared to only using the full-wave electromagnetic simulation (HFSS) which translates to quicker design time of WPT.

© 2022 The Author(s). Published by Elsevier Ltd. This is an open access article under the CC BY license (<http://creativecommons.org/licenses/by/4.0/>).

Peer-review under responsibility of the scientific committee of the 5th International Conference on Electrical Engineering and Green Energy, CEEGE, 2022.

**Keywords:** Co-simulation; CSCMR; Magnetic resonance; SCMR; Self-resonant; Wireless power transfer

## 1. Introduction

Wireless power transfer (WPT) via magnetic resonance has been explored more in the past two decades and more research continues to gain momentum in this domain Chau et al. [1]. This design can easily be scaled down to suit small footprint applications [2]. More specifically, Conformal Strongly Coupled Magnetic Resonance (CSCMR)

\* Corresponding author.

E-mail addresses: [molefikhetha@cut.ac.za](mailto:molefikhetha@cut.ac.za) (M.J. Makhetha), [emarkus@cut.ac.za](mailto:emarkus@cut.ac.za) (E.D. Markus), [aabumahfouz@csir.co.za](mailto:aabumahfouz@csir.co.za) (A.M. Abu-Mahfouz).

<https://doi.org/10.1016/j.egy.2022.08.261>

2352-4847/© 2022 The Author(s). Published by Elsevier Ltd. This is an open access article under the CC BY license (<http://creativecommons.org/licenses/by/4.0/>).

Peer-review under responsibility of the scientific committee of the 5th International Conference on Electrical Engineering and Green Energy, CEEGE, 2022.

WPT system is more compact due to its design and to achieve optimal power transfer, accurate design of a CSCMR-WPT system is required. For instance, the link between the resonator and the source/load coil has to be of certain dimensions to avoid impedance mismatch and frequency splitting between the wireless power transfer link.

3D electromagnetic (EM) field simulation solver is one of the most utilised approaches when designing WPT systems. However, simulations of complex coils or loops with fine mesh in a 3D EM solver needs considerable computational time/resources and a trade-off is often required between solution accuracy and a quicker simulation run time. The authors in Rozman et al. [3] investigated different circular coils using MATLAB analysis. In their research, different derived formulae were analysed in MATLAB and different WPT parameters such as the resonant frequency ( $f_r$ ), self-inductance ( $L$ ), quality factor ( $Q$ ) and capacitance ( $C$ ) of the coil were estimated. This method has notable benefits in that it makes designing an optimal WPT system quicker, as the simulation time is less, and computational resources used are less intense. However, the authors only considered circular coils and only relied on the MATLAB estimated results for their fabrication. This posed a challenge as different samples had to be fabricated before the verification of the estimated results was made, and this contributed to longer design time. In Khan et al. [4], the authors presented a method to estimate mutual and self inductances to design and optimise a near field WPT link. In their study, the self-inductance of wire wound coils was estimated using the Archimedean spiral shape with verifications on 3D EM simulations. This technique reduced simulation time and was easy to implements. Conversely, the authors avoided complex geometrical parameters in their study for better and accurate results.

With the rapid advancements in wireless technologies, WPT systems become an integral part in these innovations. More precise but conservative methods need to be deployed in the designing of WPT models in order to speed up the design times and to assure accuracy of the system designs. To speed up simulation times while keeping the accuracy of results, the authors in Römelsberger and Wolff [5] demonstrated how using Statistics on Structures (SoS) in combination with 3D electromagnetic simulator (High Frequency Structure Simulator (HFSS)) and OptiSLang yielded optimal results for the optimisation of a dual band antenna while having less simulation run times. With the above-mentioned challenges and considerations, this paper studies an optimal CSCMR-WPT system operating at 40.68 MHz which falls within the Industrial, Scientific and Medical (ISM) band. The selected ISM band is more flexible for mobile services and can operate a self-resonant WPT system with less complexity. The CSCMR design was previously proposed and developed in Hu and Georgakopoulos [6]. As shown in our previous work [7], the analysis develops from an equivalent circuit, then the derived mathematical formulae are fed and analysed in MATLAB to find the estimated optimal resonator loops (square) parameters for the CSCMR-WPT. Thereafter, the model is developed using 3D simulations (HFSS) to obtain the best fit source/load loop that fits concentrically inside the resonator loop. This system is then analysed through sensitivity analysis using co-simulation between HFSS and OptiSLang to yield optimal system. The optimal resonator, source/load loop system is then fine-tuned in HFSS and the complete WPT system comprising the source loop, resonator (Tx), resonator (Rx) and the load loop is then simulated to determine the transmission efficiency of the system.

In summary, the present article contributes as follows:

- We propose a less complex self-resonant CSCMR-WPT system with high transmission efficiency.
- Development of MATLAB analysis to provide the estimated dimensional and electrical parameters of square CSCMR-WPT which translates to quicker conceptualisation of a CSCMR-WPT system through mathematical analysis.
- Optimisation of dimensional parameters of the loop such as thickness, outermost length and width to yield high quality factor while achieving the small footprint design of a CSCMR-WPT suitable for low power sensor devices.
- Through co-simulation between HFSS and OptiSLang, quicker optimisation run times are achieved by utilising a surrogate model that results from meta model of optimal prognosis.

This paper is organised as follows: Section 2 reviews the work related to WPT design simulation techniques. Section 3 gives a theoretical analysis for SCMR WPT systems. In Section 4, a comparison is made between the capacitor-loaded and the self-resonant CSCMR-WPT systems. Section 5 discusses the optimisation of CSCMR-WPT using co-simulation and gives some advantages of this method. The results and are given in Section 6 and conclusions are drawn in Section 7 with future work in Section 8.

## 2. Related work

In this section, this paper's distinctiveness is highlighted by distinguishing it from previous studies and literature considered relevant to WPT. Furthermore, the importance of co-simulation and faster simulation run times in the development of efficient WPT-related applications are highlighted. We found several articles pertaining to simulation of WPT exclusively using MATLAB, and comparison of using a combined HFSS/Q3D, Designer/ADS and MATLAB as opposed to only HFSS for optimal WPT, general overview of electromagnetic field simulation solver and CSCMR-WPT in specific sensor devices. However, to the best of our knowledge, we found no specific study combining the capabilities of mathematical formulae and MATLAB analysis, verified by the power of 3D EM field simulation solver with co-simulation between HFSS-OptiSLang where electromagnetic field distributions of the system can be observed.

In Römelsberger and Wolff [5], the authors presented an optimisation technique whereby OptiSLang and statistics on structures in combination with ANSYS HFSS were used for faster optimisation of a dual-band antenna. In their work, the dual-band antenna was designed, then the resonant frequencies and magnetic field distributions were observed in HFSS. Then, the sensitivity analysis was performed to determine the MOP which in turn was used for optimisation. The authors emphasised that the antenna geometry must have enough free parameters that may be modified in order to achieve numerous design goals, including having the proper centre frequencies. This led to a more complex design which takes significant computational resources to simulate, hence the technique of combining different simulation software and methods to curb this challenge.

The authors in Jolani et al. [8] provided an optimisation scheme for magnetically coupled resonance (MCR)-WPT using dynamic link between Q3D /HFSS (for extracting mutual inductance and RLC components), Advanced Design System (ADS)/ Designer (for equivalent circuit model analysis) and MATLAB (for optimisation algorithm implementation). It was noted that a direct application of full-wave electromagnetic simulations for the proposed system would require significant amount of CPU and RAM to run. Furthermore, the authors pointed out that by employing the dynamic link, the overall computing time for each simulation with a relatively fine-mesh was lowered to only 3.4 percent of the time necessary for a full-wave simulation. Different from the above-mentioned literature, our article focuses on providing an alternative technique that uses less computational resources while speeding up the design and fabrication of a WPT system.

## 3. Four-loop wireless power transfer model

A conventional wireless power transfer system using Strongly Coupled Magnetic Resonance (SCMR) comprises four coils of which two act as the source loop and the load loop, while the other two are resonators (Tx loop and Rx loop) as shown in Fig. 1(a). SCMR system works in such a way that the source loop is inductively coupled with the Tx loop, and likewise, the load loop follows the same sequence with the Rx loop. The resonator loops are designed to operate at the frequency where their quality factor ( $Q$ ) is at its maximum and the chosen frequency of operation must coincide with this frequency. The advantage of having the Tx loop and the Rx loop operating at specified resonant frequency ensures strong energy coupling and makes the system less prone to other resonating material around it. This also ensures efficient power transfer between the source/load loops.

In the system shown in Fig. 1(a),  $d1$  is the spacing between the source loop and the Tx loop,  $d2$  is the spacing between the Tx and Rx loops and  $d3$  is the spacing between Rx loop and load loop. A typical SCMR system has an optimum spacing for  $d1$  and  $d3$  where the efficiency is maximum [9]. Actually, any spacing  $d1$  and  $d3$  beyond these optimum values will result in efficiency decrease. Taking these factors into consideration, it is clear that for the SCMR system to optimally transmit power it should have certain dimensions as shown in Fig. 1(a), which can be bulky when the system is being utilised for small devices/applications. Therefore, conventional SCMR systems can occupy large volume and this makes it difficult to incorporate the system into various applications such as, wearable monitoring devices and biomedical implants.

An equivalent circuit model of the four loop CSCMR system with one pair resonators, a source loop and load loop is derived as depicted in Fig. 1(b). All mutual inductances are taken into account in this system.

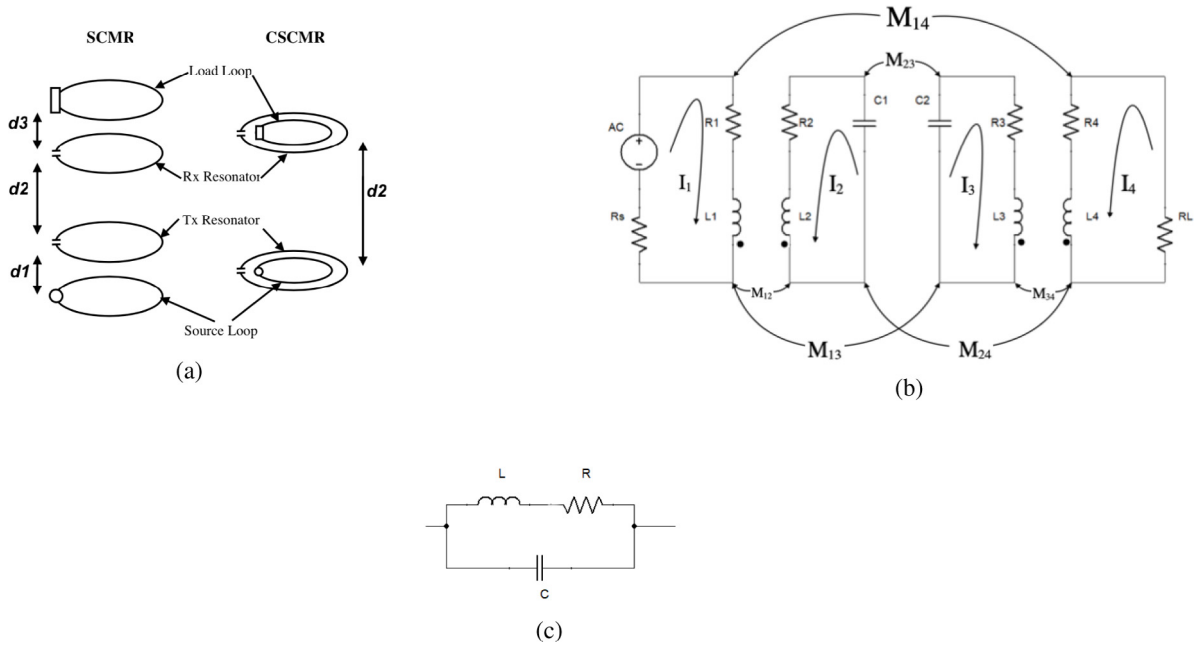

Fig. 1. WPT system, (a). SCMR and CSCMR comparison, (b). Equivalent circuit model, (c). RLC representation of the resonator loop.

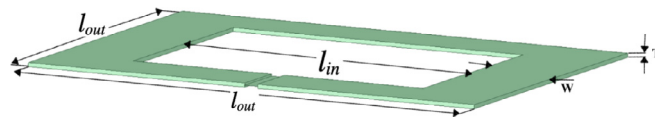

Fig. 2. Loop model geometry.

Based on the circuit model shown in Fig. 1(b), using Kirchhoff’s Voltage Law (KVL) for a four-port network analysis, the equivalent circuit model can be described by the formulas given below [10]:

$$\begin{aligned}
 V_S &= (R_S + R_1 + j\omega L_1) * I_1 + j\omega M_{12} * I_2 + j\omega M_{13} * I_3 + j\omega M_{14} * I_4 \\
 0 &= j\omega M_{21} * I_1 + (R_2 + j\omega L_2 - j/\omega C_1) * I_2 + j\omega M_{23} * I_3 + j\omega M_{24} * I_4 \\
 0 &= j\omega M_{31} * I_1 + j\omega M_{32} * I_2 + (R_3 + j\omega L_3 - j/\omega C_2) * I_3 + j\omega M_{34} * I_4 \\
 0 &= j\omega M_{41} * I_1 + j\omega M_{42} * I_2 + j\omega M_{43} * I_3 + (R_L + R_4 + j\omega L_4) * I_4
 \end{aligned}
 \tag{1}$$

The CSCMR system will have maximum efficiency when working at resonance, the resonant frequency can be determined as:

$$f_r = \frac{1}{2\pi \sqrt{L_i C_i}}
 \tag{2}$$

With the  $i_{th}$  loop  $i = 1, 2, 3$  or  $4$ . It is also required that the resonators have high Q-factor for the system to be efficient, Q-factor of a loop can be expressed as follows:

$$Q_i = \frac{2\pi f_r L_i}{R_i}
 \tag{3}$$

The coupling coefficient between two loops can be derived as:

$$k_{ij} = \frac{M_{ij}}{\sqrt{L_i L_j}}
 \tag{4}$$

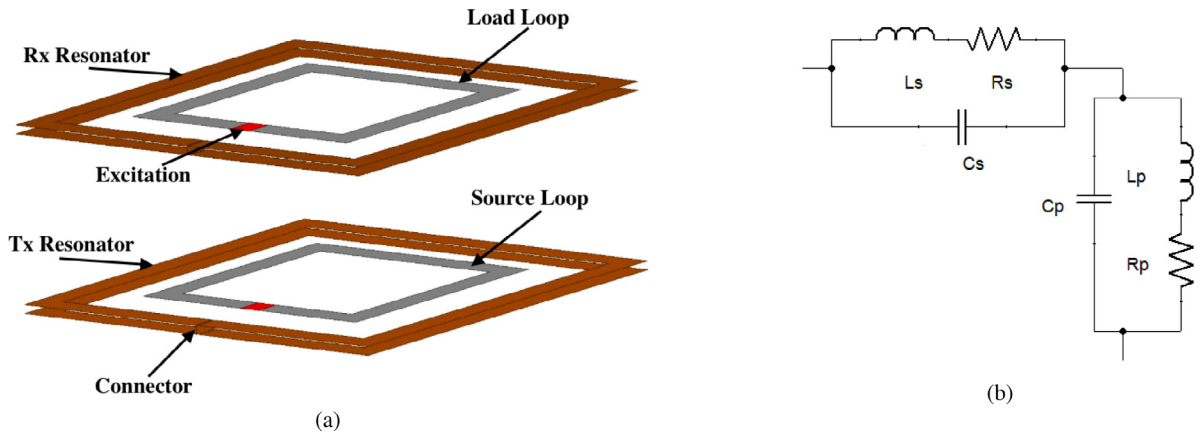

Fig. 3. A 2-layer WPT system, (a). A 2-layer self-resonant CSCMR-WPT system, (b). A 2-layer resonator with self-capacitance.

Taking Eqs. (2) and (3), efficiency can be derived by substituting the Q-factor and the coupling coefficient to get:

$$\eta = \frac{4k_{21}^2 k_{32}^2 k_{43}^2 Q_2^2 Q_3^2 Q_1 Q_4}{(1 + k_{12}k_{21} Q_1 Q_2 + k_{23}k_{32} Q_2 Q_3 + k_{34}k_{43} Q_3 Q_4 + k_{12}k_{21}k_{34}k_{43} Q_1 Q_2 Q_3 Q_4)^2} \tag{5}$$

In CSCMR systems, it is very critical that the resonators are designed in a way that they resonate at the resonant frequency which coincides with the frequency where the resonators naturally have high Q-factor. This in turn ensures maximum transmission efficiency. Capacitor-loaded CSCMR-WPT systems are easy to tune to a required frequency without any hustles. The only downside to this design is that the lumped capacitors used add to the power losses of the system and the overall design cost. Conversely, the self-resonant CSCMR-WPT system does not need any lumped capacitors to be added. The system uses extra copper layers as loops and these layers can be adjusted to operate the self-resonant loop (coil) at a preselected resonant frequency. Next, the capacitor-loaded and the self-resonant CSCMR-WPT systems are discussed.

#### 4. Capacitor-loaded vs self-resonant CSCMR-WPT systems

In this section, a self-resonant CSCMR-WPT system, which includes the distributed inductance and capacitance is studied. In this kind of configuration, no lumped components are required since the system can achieve large capacitance or inductance. This also becomes beneficial as the complexity of the whole system is lessened as well as the cost involved. Fig. 3(b) depicts an equivalent circuit model of a typical self-resonant resonator. As shown in the circuit, the two layers will result in the increase in inductance which is the sum of  $L_s + L_p$ . Large parallel-plate capacitance  $C_p + C_s$  means an increase in capacitance as well. In this 2-layer resonator,  $L_s, R_s, L_p, R_p, C_s$  and  $C_p$  are the series inductance, resistance and self-capacitance. The self-capacitance of a 2-layer resonator depends on the spacing between the two layers, as such, the spacing can be adjusted to operate the resonator at the required resonant frequency.

The performed simulations compared results of a conventional capacitor-loaded and self-resonant CSCMR-WPT systems with the same geometrical parameters, with the self-resonant system having two layers (Fig. 3(a)). It is evident that the self-resonant in this case, with the given dimensions, has a higher transmission efficiency than that of conventional model while still maintaining a small footprint. External capacitors also have losses, which can reduce the Q-factor of the Tx and Rx components, lowering the transmission efficiency of CSCMR systems. The self-resonant CSCMR-WPT system can also be tuned to work at the appropriate frequency while taking into account the maximum quality factor of the resonator. In Fig. 4, the MATLAB derived [7] and the 2-layer CSCMR-WPT systems are depicted. It is worth noting that from the MATLAB derived parameters, a conventional CSCMR-WPT system was realised and then updated so that it can be self-resonant, hence an added layer making a 2-layer CSCMR-WPT. From the presented data it can be seen that the MATLAB derived system is not far away from other conventional

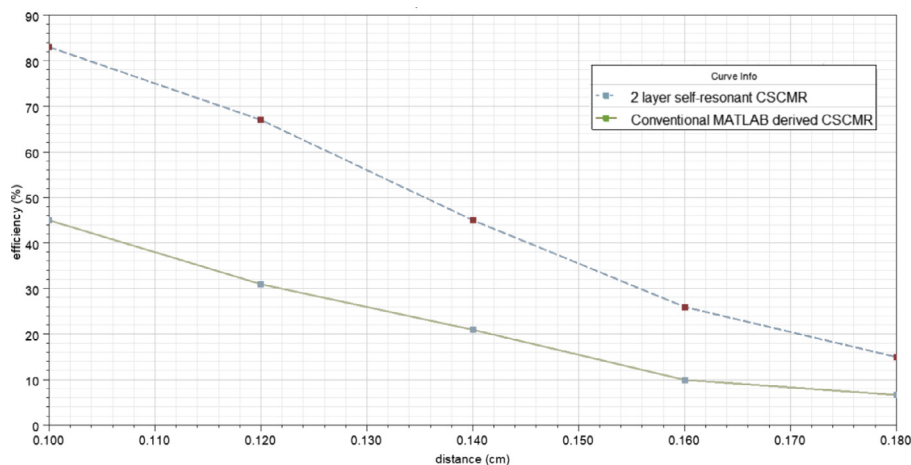

Fig. 4. Comparison of the conventional MATLAB derived CSCMR-WPT system with the proposed 2-layer self-resonant model.

models in literature. The transmission efficiency at 100 mm, which is slightly above the systems' maximum point of transmission which coincides with the systems' outermost length which in this case of 95.5 mm, has a maximum attainable transmission efficiency of 46% as shown in Fig. 4. On the other hand, the 2-layer resonator loop results in increased  $L$  which translates to higher  $M$ , the coupling coefficient ( $k$ ) between the loops becomes stronger and therefore more power can be transferred effectively.

The result is a 2-layer CSCMR-WPT system having a transmission efficiency of 83% at 100 mm while keeping a small footprint.

## 5. Co-simulation between HFSS-OptiSLang for optimal CSCMR-WPT system

To design a practical yet optimal CSCMR-WPT system for small sensor devices (i.e., LPWAN devices), the physical dimensions of the WPT coils/loops need to be fairly miniature. Based on existing low power sensor devices, the size of the proposed WPT system is kept at 100 mm. The CSCMR-WPT system is realised in a way that the source/load loops sit concentrically within the transmitter/receiver resonators, this however poses a challenge when the loops are resized to achieve optimal performance, there is less room for the source and load loops. Therefore, to realise the highest practicable transmission efficiency, the critical parameters of the CSCMR-WPT system need to be optimised. For that to be achieved, the quality factor of the individual resonator, mutual coupling between resonators, frequency splitting phenomenon for the entire WPT system and input impedance of the system need to be critically studied and analysed with an accurate equivalent circuit model of the proposed CSCMR-WPT system. In this work, frequency splitting phenomenon is observed from the transmission efficiency graphs, this gives a clear indication on how severe frequency splitting is and can be remedied by changing the spacing between the resonator and the source/load loop.

With specified size constraints, critical design parameters such as the dimensions of the source/load loops, the dimensions of the Tx/Rx resonators which are dependent on but not limited to, the width ( $W$ ), thickness ( $T$ ), outermost length ( $l_{out}$ ), are derived to yield optimal transmission efficiency of the CSCMR-WPT system with specified size constraints through systematic design process. The transmitter (Tx) and receiver (Rx) are designed to transmit maximum power transfer efficiency at a separation of 100 mm, and based on the fact that the system is designed to provide efficient wireless power transfer for low power sensor devices with small footprint, the maximum dimensions for both the Tx and Rx of the system are also constrained at 100 mm. The model derived from MATLAB has identical resonators (Tx, Rx), as well as the source and load loops. This makes the analysis and assumptions less complex and also saves computational costs. Furthermore, to sustain a satisfactory quality factor of the source/load loop,  $Q_{source/load}$  has to be greater than  $1/Q_{resonator}^{(1/2)}$ ; therefore, in order to leave adequate space for the source/load loop, the resonator's inner radius has to be limited.



Input impedance of the whole wireless power transfer system is another design factor that is of paramount importance, and it greatly depends on mutual coupling which in turn depends on the self-inductance and separation of the loops. The outermost length  $l_{out}$  has significant effect on the frequency-splitting phenomenon, since an extremely large impedance angle and a relatively low amplitude will reduce efficiency. As a result, for optimum performance, an optimal radius of the source/load loops must be defined for the proposed design. In order to achieve a fully conformal system which has a small footprint, and which can easily be utilised for compact device applications, our proposed design uses conformal loops for both the source/load and resonators Tx/Rx. Also, the initial geometric parameters of the CSCMR loops are defined to be  $l_{out} = 95.5$  mm,  $l_{(out-source/load)} = 59.7$  mm,  $W = 6$  mm,  $T = 0.03$  mm. In order to have an efficient yet accurate simulation analysis and optimisation where less computational resources are used and at a shorter simulation time, some factors need to be taken into consideration.

### 5.1. Co-simulation

Simulations run using full-wave electromagnetic field to determine the mutual coupling and other coupling parameters requires high computational costs. In this work, for the capacitor-loaded CSCMR, with the source/load loop with thickness of 0.035 mm, width of 6 mm and the outermost length of 87 mm as depicted in Fig. 2, using HFSS alone as the primary simulation software, the computational time required to run a full-wave simulation with reasonably fine-mesh is around 95 min with a custom build computer equipped with AMD Ryzen 5 1600 six-Core Processor with 3.20 GHz CPU and 16 GB RAM. This computational time becomes more than twice as long (220 min) when the model simulated is a 2-layer self-resonant CSCMR shown in Fig. 3(b), with the same physical dimensions as the capacitor-loaded model. To optimise all important design parameters for both the capacitor-loaded and the 2-layer self-resonant CSCMR-WPT designs (e.g., the width of the loop, the dimension of the source and load loop, thickness of the loop and the outermost length), the full-wave electromagnetic simulation would require high computational cost as well as simulation time.

To overcome this challenge, a co-simulation between HFSS and OptiSLang is used in this work. Firstly, the influence of different physical parameters for the resonators and the source/load loops are studied using the derived formulae and analysed on MATLAB [7]. Then, HFSS is used to determine the self-inductance ( $L$ ) and the quality factor ( $Q$ ) of the resonator loop. With the dimensional restrictions considered, a co-simulation between HFSS and OptiSLang is performed to determine the best fit values of the source/load loops (source and load loops are the same dimensions) for the highest achievable transmission efficiency analytically. The optimisation entails sensitivity analysis which provides a clearer view on the selected parameters to be optimised for the MATLAB derived WPT (conventional) system. In this analysis, the effects as well as the percentage influence of each parameter with respect to given outputs/goals is observed. This makes it clear to see the tradeoffs that need to be considered between the outputs and goals. In the sensitivity and optimisation analysis a combination of the inner length and the outermost length of the loop is termed startHelix ( $SH$ ) which is easily understood by the co-simulation. The loops are then fine-tuned in HFSS then the transmission efficiency is determined. Sensitivity analysis as well as the optimisation procedure are described next.

### 5.2. Sensitivity analysis and optimisation

The parametric simulation can first be performed using ANSYS HFSS tool which is favourably suited to perform such simulations:

- For WPT simulations, HFSS has a frequency domain solver that has proven to be very efficient.
- Optimum tradeoff between computational effort and physical and geometric accuracy is permissible by the finite element method which uses a conformal mesh.
- Its adaptive meshing reduces the impact of numerical errors on performance and guarantees numerical precision in parametric studies instinctively.

It is necessary to understand the dependencies of the quantities of interest on various parameters in order to optimise the design. Conversely, it becomes quite a complex task for this number of parameters to do by hand. In order to overcome this challenge, an optimisation tool like OptiSLang in co-simulation with HFSS can be utilised.

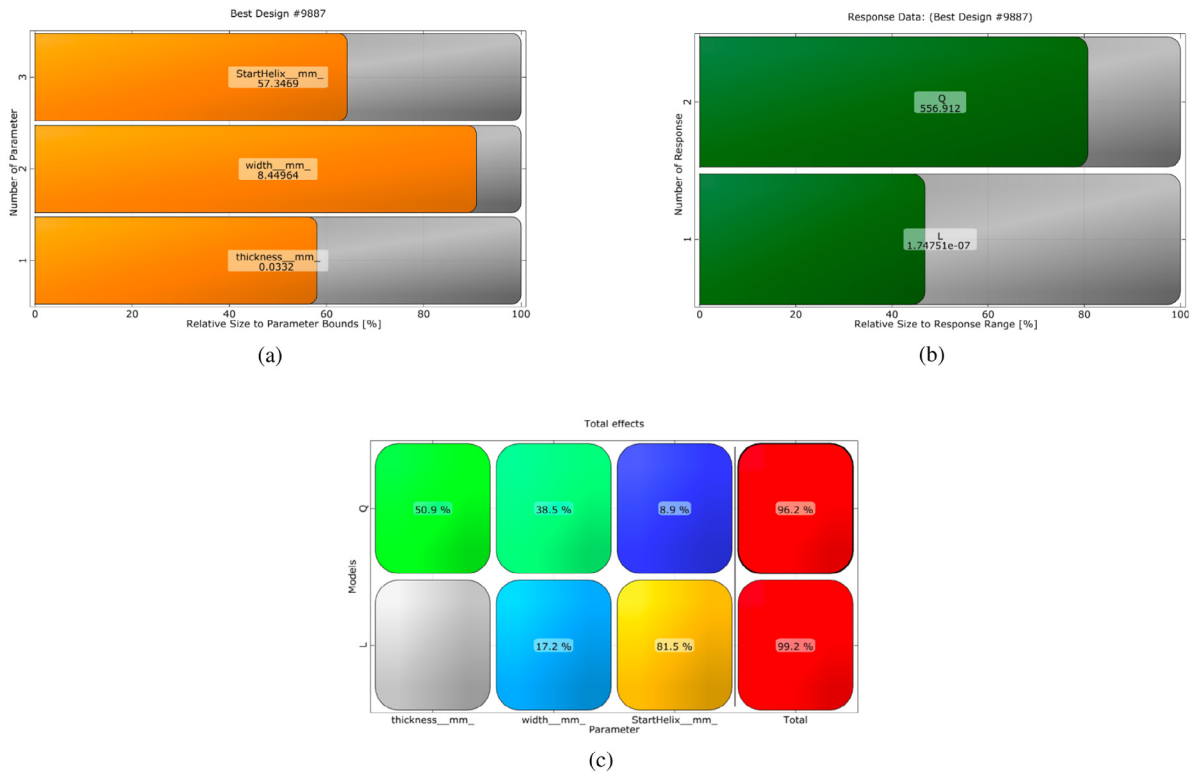

**Fig. 5.** Sensitivity analysis and optimisation, (a): Best design optimised loop dimensions, (b). Best design with depicted tradeoff of  $L$  and improved  $Q$ , (c). Meta Model of Optimal Prognosis, total parameter effect.

OptiSLang, which employs Latin hypercube sampling, allows for a fully automated design of experiments with a fair number of samples, resulting in a very evenly distributed sampling of the design.

## 6. Results and discussions

On the basis of the sampling links between geometric parameters and outcome quantities, a Meta Model of Optimal Prognosis (MOP) can be found (see Fig. 5(a), Figs. 5(b) and 5(c)). The response surface for the result quantity under consideration is established by an MOP acquired by picking some 60% of the calculated design points. The Coefficient of Prognosis (CoP) is then determined through the remaining 40% of the calculated design points which are used to establish the quality of the response surface. OptiSLang divides the design points in a variety of ways, and the response surface with the best CoP is chosen as the MOP. The MOP can be used for optimisation if the prognosis quality is satisfactory. This means that when carrying out the optimisation, no new points must be determined using numerical simulation. The MOP is instead used to predict the results for the relevant design points. This technique makes OptiSLang very effective in that the optimisation run is quickened.

Fig. 5(c) depicts relationship between different input and output quantities. There is for instance a rather strong, linear relationship between the startHelix ( $SH$ ) and the self-inductance ( $L$ ) of the loop, while the relationship between the quality factor ( $Q$ ),  $SH$  and  $W$  also shows a linear relationship (Fig. 5(c)). Meta model of optimal prognosis for  $L$  and  $Q$  is shown in red colour as well, it depicts a good CoP of 99% ( $L$ ) and 96% ( $Q$ ). This shows that during the optimisation a tradeoff between  $Q$  and  $L$  can be considered. For this reason, considering the CoP, from the overall MOP for this quantity is good enough to run an optimisation on. Therefore, a direct optimisation will not be run from our derived model as the MOP is strong enough to run the optimisation, instead a surrogate model will be used.

By running the optimisation processes with CSCMR resonators of different geometrical parameters ( $l_{out}$ ,  $W$ ,  $T$ ), we found that the increase in the outermost length and width of the loop yielded higher quality factor, which in



**Table 1.** RLC values, design parameters.

Parameters	Tx/Rx Resonator Loop	Source/Load Loop
T (mm)	0.0332	0.0275
W (mm)	8.45	6
$l_{out}$ (mm)	88.7	47.012
$C_{Tx}, C_{Rx}$ (pF)	81	–
$Q$ (unloaded) @40.68 MHz	556	701
$f_{max}$ (MHz)	40	89
$L$ (uH)	0.175	0.113
$R_S, R_L$ (ohm)	–	50

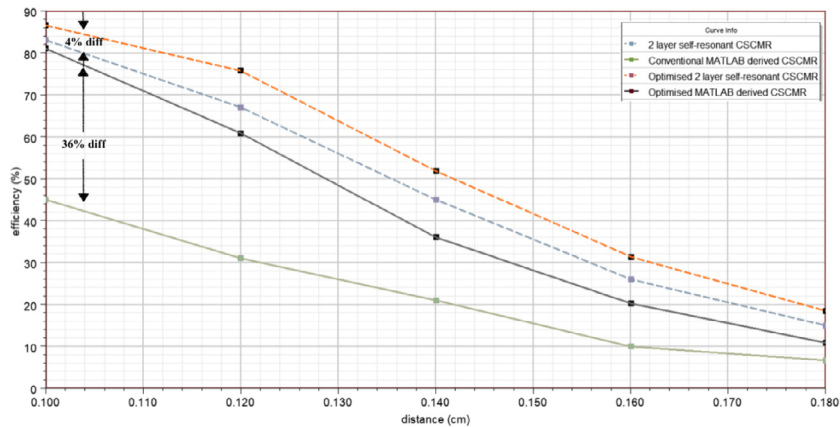
**Fig. 6.** Comparison of the Matlab derived CSCMR-WPT system and its developed 2-layer self-resonant with their optimised versions.

turn gave the highest peak in transmission efficiency. While the increase in the outermost length and width of the loop improves the quality factor, an increase beyond certain limits, based on our design constraints, causes severe frequency-splitting which is contributed by impedance mismatch. The other carefully considered decision was having both  $L$  and  $Q$  as objective functions to be maximised, this was to have an automatic restriction on the loop to avoid the optimised resonators filling up the inner radius in a quest to find the highest  $Q$ . To be specific, from Fig. 6 it is clearly depicted that the MATLAB derived CSCMR model has been enhanced, the overall footprint is reduced from 95.5 mm ( $l_{out}$ ) to 88.7 mm, the width ( $W$ ) has been increased by 10% while the thickness ( $T$ ) has been slightly reduced by 5%. The resulting effects on the output variables sees the quality factor ( $Q$ ) being increased by 30% from the initial value of 427, and self-inductance is reduced from 0.234 uF to 0.174 uF. The optimised parameters of the conformal strongly coupled magnetic resonance (CSCMR) WPT are then fine-tuned with HFSS to further improve the efficiency of the design, which then can be ready for fabrication if required (see Fig. 6). The finalised design parameters of the proposed CSCMR-WPT system are shown in Table 1.

With the optimised MATLAB derived model, the optimised 2-layer self-resonant model was also realised and showed an improvement as well from its first model. Furthermore, the self-resonant model moved from 83% to 87% transmission efficiency also keeping a small footprint with the resonators' outermost length ( $l_{out}$ ) of 88.7 mm with the height ( $h$ ) of 0.55 mm between the two layers. Considering the co-simulation and the overall computational resources when compared to only running a full-wave electromagnetic simulation, it is clear that the co-simulation is more suitable. The total computational time for each simulation with a relatively fine-mesh was reduced to 15 min using the co-simulation. Compared to the initial time of 220 min this was an improvement of 93% simulation time needed for a full-wave simulation.

## 7. Conclusion

This paper presented a mathematical and simulation analysis of different physical and electrical parameters for a wireless power transfer system. It was shown clearly from the data provided that a self-resonant CSCMR-WPT

performed better than the capacitor-loaded design. This was due to the self-resonant model having two layers which meant the inductance of the loop became twice that of a single-layer. Furthermore, the inductance had a direct influence on mutual inductance which in turn affects the coupling coefficient. This meant that the 2-layer resonator system had stronger coupling than a single-layer system, hence the higher transmission efficiency. It was also clearly shown that after a co-simulation between OptiSLang and HFSS, the overall dimensions of the resonators were reduced, which in turn reduced the entire CSCMR-WPT system footprint. The derived single loop and 2-layer resonator CSCMR-WPT systems were able to achieve their optimal power transfer efficiency at 100 mm separation with dimensions of 0.0332 mm, 8.45 mm, 88.7 mm for the resonator loops (Tx/Rx) and 0.0275 mm, 6 mm, 47.012 mm for the source/load loops. The complete optimised WPT systems for a single and a 2-layer resonator were compared and the results showed high improvement in a conventional single-layer CSCMR, while the 2-layer was also improved. The use of co-simulation proved to be an advantage in that the simulation time to run the optimisation was reduced to 7.32% (from 220 to 15 min) compared to only using the full-wave electromagnetic simulation (HFSS).

## 8. Future work

This research was centred on wireless power transfer optimisation for low power wide area networks applications by developing resonators with small footprint developed through less computational intense methods. However, future work is required in some areas:

- Further miniaturise the geometries for non-homogeneous interface like medical implantable devices which are fairly small.
- Optimisation of these sensor devices so that they are completely passive and battery-less.
- Also, the self-resonant CSCMR-WPT can be assessed on its performance when there are resonating materials and devices in its vicinity.

## Declaration of competing interest

The authors declare that they have no known competing financial interests or personal relationships that could have appeared to influence the work reported in this paper.

## Data availability

Data will be made available on request.

## References

- [1] K.T. Chau, C. Jiang, H. Wei, W. Liu, H. Wang, Direct wireless power conversion systems and their applications, *Stud Sci Technol* 10 (1) (2021) 5–12.
- [2] J. Nilsson, J. Borg, J. Johansson, Load-dependent power transfer efficiency for on-chip coils, *Analog Integr Circuits Signal Processing* (2021) 1–14.
- [3] M. Rozman, M. Fernando, B. Adebisi, K.M. Rabie, R. Kharel, A. Ikpehai, et al., Combined conformal strongly-coupled magnetic resonance for efficient wireless power transfer, *Energies* 10 (4) (2017) 498.
- [4] S.R. Khan, S.K. Pavuluri, M.P. Desmulliez, Accurate modeling of coil inductance for near-field wireless power transfer, *IEEE Trans Microw Theory Tech* 66 (9) (2018) 4158–4169.
- [5] C. Römelsberger, S. Wolff, Optimization of a dual-band-antenna using statistics on structures (SoS), in: 2016 10th european conference on antennas and propagation, IEEE, 2016, pp. 1–3.
- [6] H. Hu, S.V. Georgakopoulos, Multiband and broadband wireless power transfer systems using the conformal strongly coupled magnetic resonance method, *IEEE Trans Ind Electron* 64 (5) (2016) 3595–3607.
- [7] M. Molefi, E.D. Markus, A.M. Abu-Mahfouz, Accelerated design of a conformal strongly coupled magnetic resonance wireless power transfer, in: 2021 IEEE 24th international conference on information fusion, IEEE, 2021, pp. 1–5.
- [8] F. Jolani, Y.-q. Yu, Z.D. Chen, Electromagnetic modeling and optimization of magnetic resonant coupling wireless power transfer using coil array, in: 2015 IEEE MTT-S international conference on numerical electromagnetic and multiphysics modeling and optimization, IEEE, 2015, pp. 1–3.
- [9] A. Karalis, J.D. Joannopoulos, M. Soljačić, Efficient wireless non-radiative mid-range energy transfer, *Ann Physics* 323 (1) (2008) 34–48.
- [10] F. Jolani, Y. Yu, Z. Chen, A planar magnetically coupled resonant wireless power transfer system using printed spiral coils, *IEEE Antennas Wirel Propag Lett* 13 (2014) 1648–1651.