

RHEO-PROCESSING OF SEMI-SOLID METAL ALLOYS- A NEW TECHNOLOGY FOR MANUFACTURING AUTOMOTIVE AND AEROSPACE COMPONENTS

L. Ivanchev, D. Wilkins, G. Govender, W. Du Preez, R Bean
CSIR

Abstract

The new trend in the automotive industry to produce more fuel-efficient vehicles has resulted in the increased use of aluminium and magnesium alloys. Currently liquid metal high-pressure die-casting (HPDC) fulfils the bulk of the automotive industry's needs, however, the ever increasing demands on quality and weight reduction have driven the development of new processing technologies. The inherent problems associated with liquid metal HPDC have resulted in the increased interest in semi-solid forming processes. The CSIR in SA, developed and patented a rheocasting process and equipment for semi solid casting, which is in the commercialization stage and an automotive component will be manufactured soon.

1. Introduction

Some metal forming processes are designed to be done when the metal is in solid state, i.e. below the solidus temperature, like forging, rolling, extrusion or drawing.

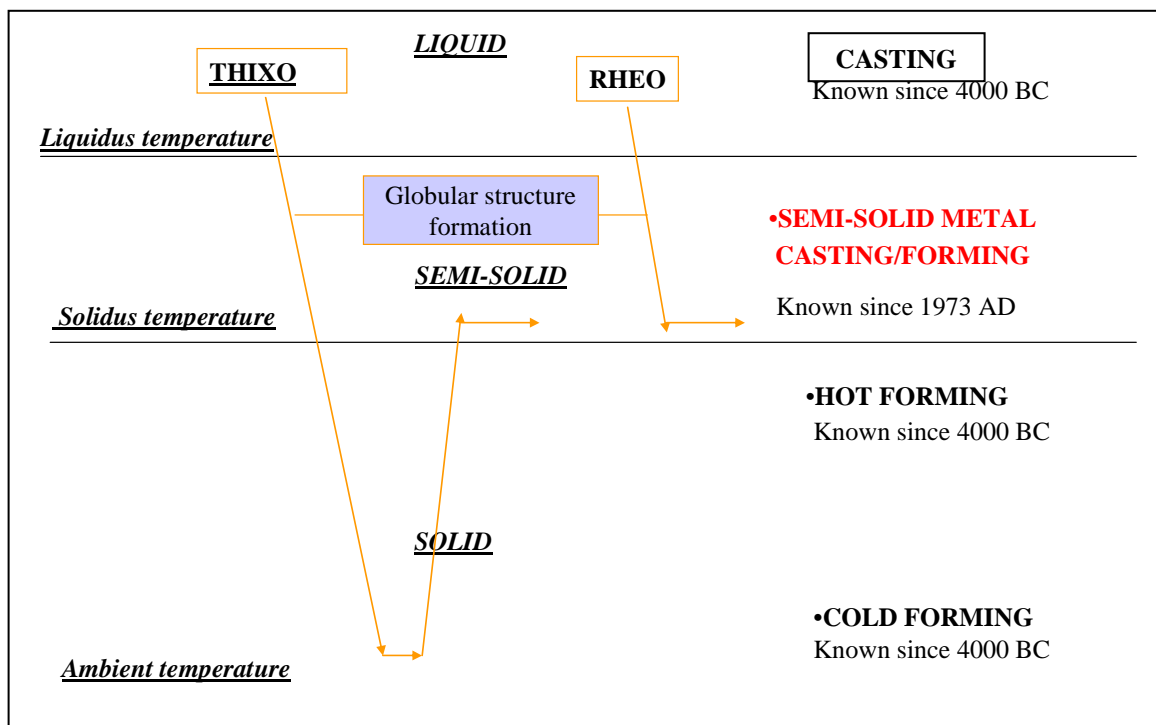

Fig.1.The basic metal forming processes presented in a schematic “Temperature-Time” diagram

On the other hand casting processes are carried out when the metal is in the liquid state, i.e. above the liquidus temperature. These two groups of technologies have been known to mankind and used for thousands of years.

About thirty years ago, it was discovered by professor M. C. Flemings and his collaborators, that a metal forming process in semi-solid / semi-liquid state is also possible and that there are many benefits for the product properties [1]. This forming process is carried out when an alloy is at a temperature between the solidus and liquidus. Only metal alloys can be brought into the semi solid state, because they solidify in a temperature range, but the process is called Semi-Solid Metal (SSM) Technology for simplicity (Fig.1)

2. SSM processes

A semi-solid metal is a thixotropic metal used in casting and forging operations. Thixotropy is a property of temporarily becoming liquid when sheared and turning to a gel when static, like margarine or toothpaste.

For a metal to be thixotropic it must:

1. Be heated to the semi solid region of temperatures;
2. Have a globular microstructure at the processing temperature, Fig. 2b, instead a dendrite one, Fig.2.a.

If these conditions are fulfilled, the metal slurry can be formed in a die by a High Pressure Die Caster (HPDC) or a forging machine.

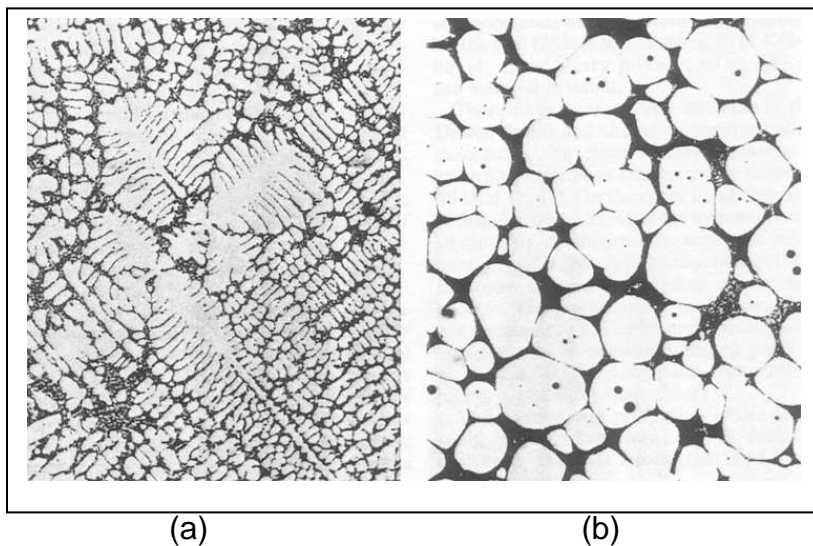

Fig. 2. Dendrite structure, typical for liquid castings (a) and globular

Structure, (b) typical of a semisolid casting.

There are two versions of SSM technology, which can produce metal slurry with desirable globular structure in shape and size at a proper semi-solid casting temperature. These are Thixocasting and Rheocasting processes.

Thixocasting is a two steps process. In the first step, a continuous casting process upgraded with a stirring device is used to produce solidified metal with non-dendritic structure. Rods with diameters from 3" to 6" are cast. There are few companies in the world that specialize in this casting/stirring technology, all of them situated only in the northern hemisphere. During the second step, rods are cut on billets and then heated in an induction machine to the desired temperature. During the heating process, slurry billets with globular structure suitable for SSM forming are produced, see Fig.3. The slurry billets are cast in a metal die by a HPD casting machine. A big disadvantage of thixo process is that the scrap cannot be recycled on site.

Rheocasting is a one step process. The molten metal is treated by cooling or by cooling/stirring from liquid to semi solid temperature in order to produce a slurry with globular shape of the solid phase particles and hence injected directly into the die, as illustrated in Fig.4.

The big advantage of the rheo process in comparison with the thixo process is that the slurry with globular structure can be made on demand and "in house". The stock material can be any standard alloy cast by other methods like squeeze, gravity or HPD casting. The chemical composition of the cast metal can also be modified and tailored to meet the quality and property specifications of the components. The rheo process does not need imported material with non-dendritic structure. Scrap and runners can be directly re-melted in the rheocasting machine. These facts contribute to a lower production cost of the rheo castings.

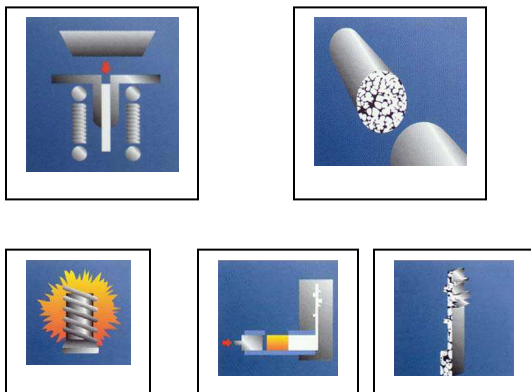

Fig.3. SSM Thixo process

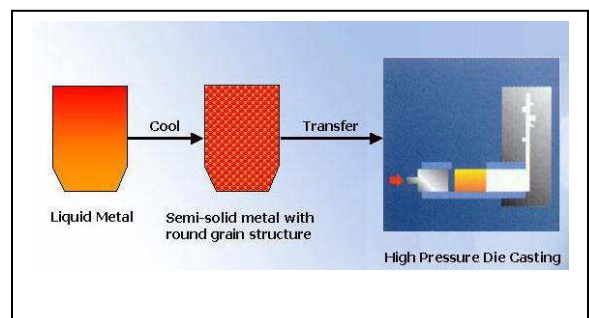

Fig.4. SSM Rheo process

During the last few years, an increasing interest in the rheo process, from both research centres and industries, have been recorded. The first rheocasting

technology called New Rheo Casting-NRC, developed by Ube, Japan is already on the market and was implemented in mass production by a number of HPDC foundries in Europe and North America.

The trend for application of the rheo process has become very strong and few new technologies have been reported recently [2, 3, 4, 5, 6, 7, 8, 9, 10,11, 12].

3. Advantages of SSM forming processes

The main technological advantages of the SSM forming process are as follows:

- High wall thicknesses and different wall thicknesses can be designed
- Better mechanical properties, for example elongation
- Low gas porosity due to laminar filling and good ailing
- Low solidification porosity due to a high solid fraction proportion ($f_{\text{solid}} \sim 50\%$)
- Production of thin walled components
- Allows for the casting of wide range of alloys inclusive of high strength wrought alloys.
- Longer life of the dies
- Joining by LASER, MIG or TIG welding possible
- Heat treatment from T0 - T7 possible
- Near net-shape parts production
- Excellent surface finishing

4. Application of SSM casting

Typical automotive components, suitable for SSM forming are:

Brake master cylinder	Rocker arms
Brake calliper	Pulley
Engine bracket	Clutch cylinder
Petrol collector	Knuckles
Power steering valve box	Suspension arms
Belt covers	MMC components
Oil pump housing	Pistons
Fuel rails	Motor housing
Wheels	

Although the SSM processes have significant benefits in terms of quality of component and high productivity, it must not be assumed that it would be suitable for every component. The feasibility of using SSM against the main casting processes rheo-casting(RC), thixo-casting(TC), squeeze casting(SC), high pressure die casting(HPDC) and low pressure casting(LP) can be evaluated using Table 1.

Table 1. Weighting for evaluation the feasibility of main casting processes [13]

Properties	RC	TC	SC	HPDC	LP
Shrinkage/Porosity	3	3	2	1	2
Blow hole	2	2	2	0	2
Segregation	2	2	1	2	2
Mechanical properties	3	3	2	0	1
Wrought alloys application	3	2	1	0	2
Hot tearing	3	3	1	0	2
Metal fluidity	2	2	3	3	2
Casting cycle time	2	2	1	3	2
Die life	3	3	1	2	0
Product cost	2	0	1	3	3
Total	25	22	15	13	17

Key: (3) Excellent, (2) Good, (1) Somewhat poor, (0) Poor

5. SSM at the CSIR

A three years R&D activity in CSIR resulted in the development of a new rheo process and equipment. A pilot slurry production unit was built for production of billets up to 4.5 kg weight. This is not the limit of this technology and billets with weight of 15.5 kg were cast recently. The billets possessed very fine globular structure and the mechanical properties of cast products were fully comparable to the international achievements. The production rate was about one casting per minute.

Concept generation

Various concepts of processing technology were considered including a continuous casting process. It was decided that the molten metal had to be split into portions for the required shot weight before being conditioned in the slurry treatment unit. This was the most feasible method in terms of controlling the process, and addressing normal operating problems that may arise like electrical failure, HPDC machine failure, etc.

With respect to the treatment process, two options were investigated:

- Processing of the liquid metal to semi-solid state by stirring with an induced electromagnetic field, supplied by an AC induction coil, and air-cooling simultaneously to the desired semi solid temperature - Induction Heating /Stirring Process.
- Processing of the liquid metal to semi solid state by air cooling and applying induction heating at the end of the process to release the billet from the cup - Controlled Cooling Treatment Process.

Both processes were experimentally tested and it was concluded that the Induction Heating/Stirring Process provides a better Semi Solid Metal structure than the Controlled Cooling Treatment. The two processes were characterised by grain size, shape factor and temperature gradient. From table 2 it can be seen the Induction Heating/Stirring Process produced significantly better properties in all three areas.

Table 2. Comparison of the two rheo processes investigated

Rheo Process	Induction Heating/Stirring		Controlled Cooling Treatment	
	Value, μm	Standard deviation, %	Value, μm	Standard deviation, %
Grain size	77.5	13.5	84.8	25.7
Shape factor	1.52	4.8	1.58	9.0
Billet temperature gradient, $^{\circ}\text{C}$	3.3		9	

The above results can be explained by the stirring effect of the induction magnetic flux, which affects the crystallization process of mush metal mainly in three ways:

- (a) Disturbing the dendrite growth process by breaking up the small branches right from the beginning of the crystallization process thus decreasing the size and increasing the number of grains.
- (b) Rotating the crystal nuclei in liquid metal and providing conditions for a non-preferential directional growth thus improving the grain shape, i.e. a smaller shape factor.
- (c) Mixing the hotter and colder metal volumes in the cup, thus contributing for a better temperature profile.

Rheo Processing Slurry Maker

Once the method of preparing the slurry was decided on, a prototype machine for producing SSM billets was designed and built. One of the core requirements for the equipment and process required that it be flexible so that it could be used on both horizontal and vertical injection HPDC equipment and be implemented in most existing HPDC foundries without significant capital investment. It also had to be able to produce a billet per minute with the ability to vary the cycle time as needed.

Using these requirements, the equipment for treatment of light metal alloys from liquid state to semi solid slurry was developed, see Fig.5, [14, 15]. Cups with metal are move in a could be included in the vertical direction upwards and

stepwise through three conditioning units. Each conditioning unit consists of an induction coil and air-cooling coil. The equipment could be operated as a single coil unit, or more coils unit depending on production requirements and material being processed.

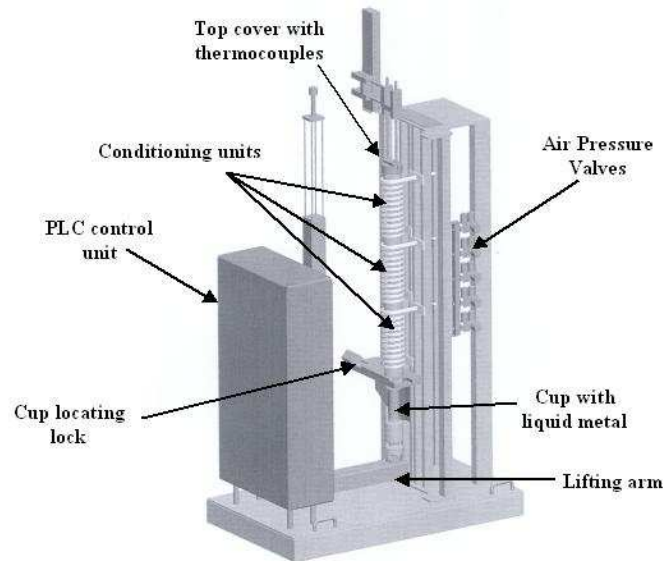

Figure 5. Rheo Processing Slurry Maker for Continuous Delivery of Semi Solid Billets

Evaluation of the Equipment and Process

The equipment was evaluated using A356 aluminium casting alloy. An 8 kW electrical tilting melting furnace with a capacity of 18-20 kg aluminium was used for melting and treatment of the molten alloy A356 before casting. The melt at 630°C was poured into austenitic stainless steel cups, consisting of stainless tubes and assembled with a consumable washer, made of the same or similar cast alloy. The washer becomes part of the biscuit after casting.

The cup charged with the liquid metal was transferred to the slurry making apparatus and processed using a three-minute induction heating/stirring and cooling cycle. The process was optimised to produce semi-solid slurries with a temperature range between 580-585°C. The power and cooling profiles used for processing of the metal are dependent on the cup size/metal volume, alloy and ambient temperature.

After completion of the slurry making process, the cup was transferred to the HPDC machine and placed in a special designed clamping mechanism of the shot sleeve [16], see Fig.6. The cup was clamped, becoming part of the shot

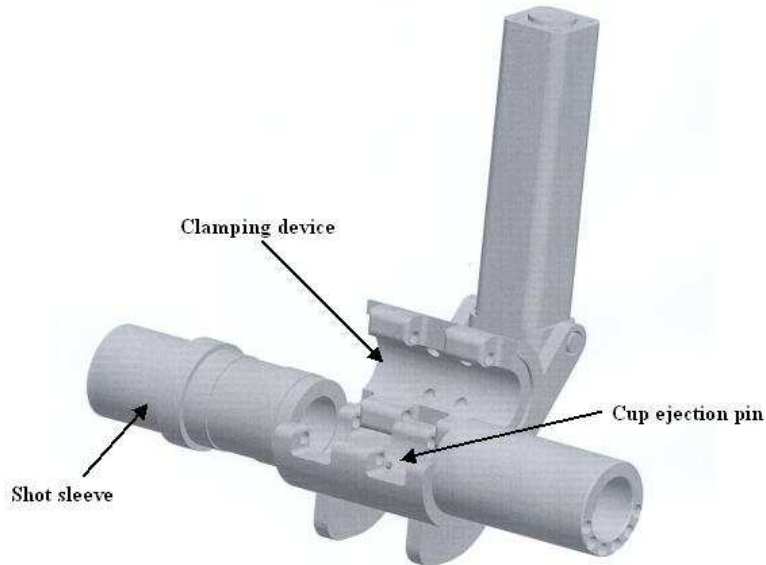

Fig. 6. HPDC machine shot sleeve with a cup-clamping device

sleeve, and the slurry metal was injected into the die (die temperature – 250°C). The aluminium washer becomes part of the biscuit. On completion of the casting, the cup is ejected and recycled. A 50 ton Edgewick HPDC machine was used during these trials. Rectangular cylindrical bars were cast for evaluation of the mechanical properties in the T6 condition. Cast bars were treated to T6 condition (540°C/6h, water quenched, 20h natural aging, 160°C/6h). Round tensile test specimens, with a diameter of 7.5 mm and gage length of 50 mm, was machined and evaluated using a 25kN Instron tensile testing machine.

6. Results and Discussion

Microstructures

The microstructural analysis revealed a globular non-dendritic structure (Fig.7). The average grain size of 200mm long billets and diameters of 60mm and 90mm diameter was determined to be 68 μ m and 85 μ m respectively, and had shape factors of 1.43 and 1.52 respectively. The larger grain size of the 90mm diameter billet was due to the lower cooling rate because of the larger volume of metal being processed. There was no evidence of entrapped eutectic, which was consistent with other rheocasting processes reported in literature [17].

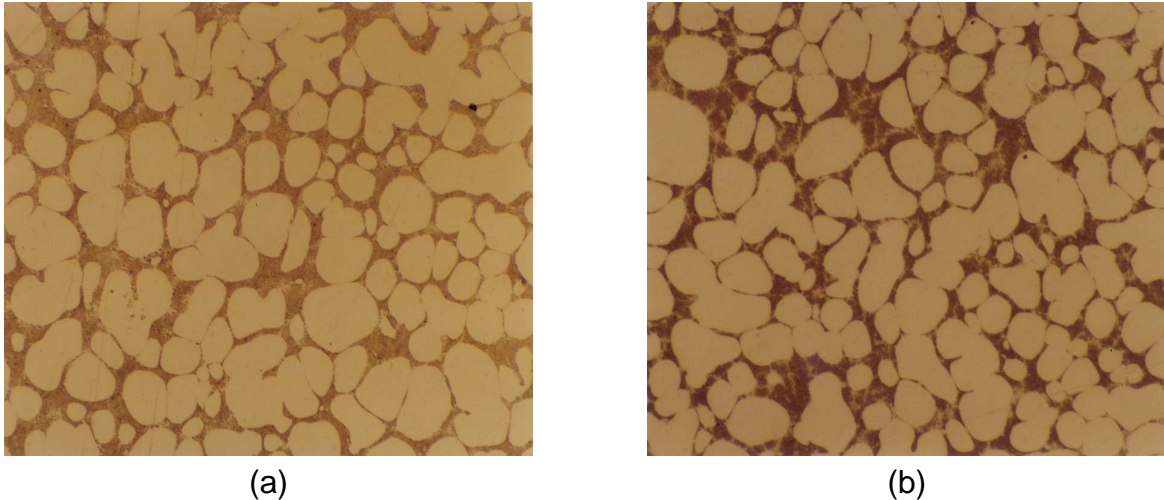

Figure 7. (a) Microstructure of a 60mm diameter billet (average grain size 68 μm and shape factor 1.43) and b) 90mm diameter billet (average grain size 85 μm and shape factor 1.52)

The structure homogeneity of a 60mm diameter by 180 mm long billet was evaluated in 6 critical positions of the volume: top cross section (edge and centre), middle cross section (edge and centre) and bottom cross section (edge and centre). The values of the grain size, $D\alpha$ and shape factor, $F\alpha$ of the α -primary crystals measured at these positions presented in Table 3 quantified the visual examination showing very consistent grain sizes and shape factors. The standard deviation for $D\alpha$ and $F\alpha$ were 8.8% and 3.9% respectively. The microstructure was uniform throughout the billet with no evidence of liquid segregation.

Table 3. Image Analysis of a 60mm diameter billet after rheo processing.

Structure characteristics	Top edge	Top centre	Middle edge	Middle centre	Bottom edge	Bottom centre
$D\alpha$, μm	68	72	74	65	70	72
$F\alpha$	1.46	1.50	1.48	1.52	1.51	1.48

Mechanical Properties

The tensile properties after HPDC were evaluated in order to assess the overall performance of the process with the new shot sleeve concept. The shot sleeve system was found to be very effective, eliminating the need for a secondary billet transfer system. Rectangular specimens were cast and tensile specimens were machined from these samples. The chemical analysis of the material after casting (Table 4), showed that the material was within specification. Mechanical properties in the T6 condition are shown in Fig. 8. The tensile and yield strengths were found to be within a tight window while the ductility varied

between 4.8 to 8.8% The average mechanical properties (Table 5), were comparable with a similar alloy cast using the Ube process [18]. It must be noted that the die used for preparation of the specimens for mechanical testing has not been optimized; hence, further improvements of on these values (particularly of the ductility) may be achieved.

Table 4. Chemical composition of material after rheo-processing and HPDC

Element	Si	Fe	Mn	Mg	Ti	Cu	Sr	Zn	Al
Wt %	6.62	0.13	0.01	0.43	0.074	0.02	0.0068	0.05	Bal.

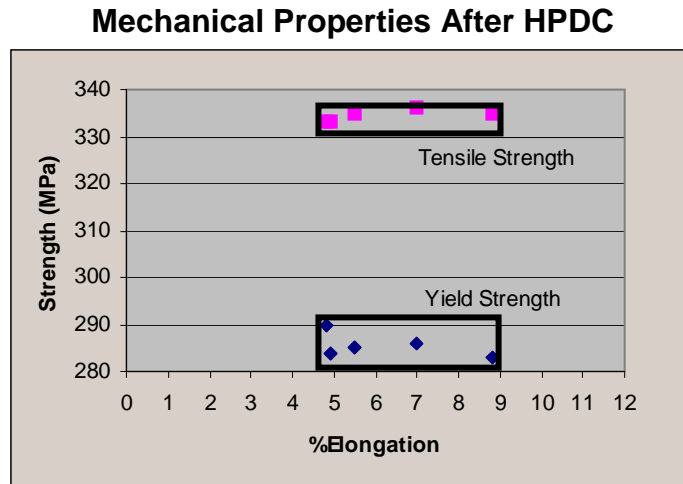

Figure 8. The mechanical properties after HPDC and T6 heat treatment

Table 5. Average tensile test results after T6 heat treatment

Heat treatment condition	Yield strength, R0.2 MPa	Tensile strength, Rm MPa	Elongation, A %
T6	286	334	6.2

7. Conclusions

Based on the results obtained during this research, it was concluded that a reliable and stable process and equipment for treatment aluminium alloy A356 from liquid to semi-solid state had been established. The method has since also been successfully applied for rheo casting of magnesium alloy AZ91D and Al-Si Metal Matrix Composites F3S.20S. Slurry billets with diameters of 50 mm, 60 mm and 90 mm diameters and lengths up to 200mm have been cast. These dimensions are not the limits of the process and billets with bigger diameter and length can be produced.

The typical characteristics of the mush cast billets achieved in this work are:

- Maximum temperature variation in a single billet: 4°C
- Maximum temperature variation in continuous casting of billets: 7°C
- Grain size: less than 85 μm
- Shape factor: less than 1.52
- Mechanical properties in "T6" condition:
Yield Stress 283-290 MPa, Ultimate Tensile Strength 333-336 MPa,
Elongation 4.8-8.8%
- Production rate: one billet per minute.

References

1. R. Mehrabian and M.C. Flemings, Die Casting Engineer (July-Aug. 1973) 173-182
2. Richard et al, US 6,640,879 B2, Nov.4, 2003.
3. Oril, US 6,595,266 B2, Jul.22, 2003.
4. Norville et al, US 6,432,160 B1, Aug.13, 2002.
5. Lombard et al, US 2003/0102103 A1; Jun.5, 2003.
6. Flemings et al, US 2003/0079854, A1, May 1,2003.
7. Aoyama et al, US 2003/0062144, A1, Apr. 3, 2003.
8. Winterbottom et al, US 2003/0037900, A1, Feb.27, 2003.
9. Flemings et al, US 2002/0096231, A1, Jul.25, 2002.
10. Adachi et al, EP 0 745 694 A1, Dec. 1994.
11. Adachi et al, US 6,165,411, Dec. 2000.
12. J.A. Yurko et al, "Commercial Development of the Semi-Solid Rheocasting (SSR tm) Process", Metallurgical Science and Technology, 21 (1) (June 2003), 10-15.
13. Ube Machinery Corporation,2000, New Rheocasting, Promotional brochure, Japan.
14. R. Bruwer et all, WO 2004/07/0068 A1, PCT.
15. L. Ivanchev et all, "Method and Apparatus for Rheo-Processing of Semi-Solid Metal Alloys", 8thS2P Conference, Cyprus, 2004.
16. L. Ivanchev and D. Wilkins, "Processing of a Molten Alloy", SA Provisional Patent Application, Nov. 2003.
- 17.C. Crespo, et al, "Slurry Approach to Manufacturing Automotive Components", Proceedings of the 7th S2P, Tsukuba, Japan, 25-27 September 2002, 131-137.
18. M.Rosso et al, "Mechanical and Microstructural Characterization of Semisolid Rheocast A356 and A357 Aluminium Alloys for Automotive Applications", Proceedings of the 7th S2P, Tsukuba, Japan, 25-27 September 2002, 15

