

CHARPY IMPACT TOUGHNESS AND PRIOR β -GRAIN SIZE IN Ti6Al4V MANUFACTURED BY HIGH SPEED, HIGH-POWER (3KW) LASER POWDER BED FUSION

D.F.Louw*¹

¹CSIR National Laser Center, Pretoria, South Africa
dlouw@csir.co.za

ABSTRAC

The build rate of a laser powder bed fusion machine can be increased by increasing the laser power. The current paper shows that the use of higher laser power results in a positive change in impact toughness of Ti6Al4V. Laser powder bed fusion is an additive manufacturing technique that can produce functional metal components. The use of higher laser power is accompanied by an increase in scan speed. Furthermore, a higher scan speed results in a faster solidification rate. During processing of Ti6Al4V prior β -grain size is proportional to solidification rate. In this study prior β -grain size of Ti6Al4V produced by high power laser powder bed fusion is compared to Ti6Al4V processed by conventional low power machines. The sub-size (55x10x2.5mm) Charpy impact toughness of Ti6Al4V produced in this study was measured to be 8-10J which is higher than the 6J measured for Ti6Al4V produced by low power laser powder bed fusion. This difference is discussed by comparing prior β -grain size of the two materials.

*Corresponding author

1. INTRODUCTION

Laser powder bed fusion is an additive manufacturing (three dimensional printing) technique that is capable of making functional metal components. One of the current limitations of the technology is the slow build rate of commercially available machines. It has been demonstrated that the build rate can be increased by increasing the laser power accompanied by an increase in the traverse speed of the laser beam. The current article shows that an increase in laser power has a positive effect on the final material's mechanical properties by comparing the impact toughness and prior β -grain size of Ti6Al4V produced by a conventional low power laser powder bed fusion machine to Ti6Al4V produced with an experimental setup equipped with a 3kW laser.

Due to the layer wise building, laser powder bed fusion of Ti6Al4V produce a microstructure that consists of columnar prior β -grains. These grains form epitaxial on the grains in underlying layers and experience planar growth [1-4]. During the process the base plate and underlying layers acts as a heat sink while heat is consistently added by the laser beam from above. The result is that heat is conducted away from the weld pool in the z-direction and this produces the vertical columnar grains. The tendency of the Ti6Al4V alloy to experience planar growth is associated with the fact that the alloy solidifies over a narrow temperature range [1].

By cooling the Ti6Al4V alloy from above the β -transus temperature a lamellar microstructure consisting of α -colonies inside prior β -grains forms. The size of the α -colonies determines the effective slip length. Therefore, smaller α -colonies result in better mechanical properties. The size of the α -colonies is determined by the rate at which the material cools from above the β -transus temperature. Therefore, the mechanical properties can be improved by increasing the rate at which the material cools from above the β -transus temperature. However, when the cooling rate is fast enough that a martensitic microstructure forms the fracture mechanism change from trans-crystalline to inter-crystalline and the size of prior β -grains now has the greatest effect on mechanical properties [5].

The mechanical properties of Ti6Al4V made by laser powder bed fusion can approach that of wrought material when an appropriate post processing heat treatment is applied [3, 6]. Several studies have been conducted to characterize the defects, microstructure and mechanical properties of the material in the as-built condition as well as after heat treatment. However, limited literature is available regarding improvement of the microstructure in the as-built condition. Vrancken et al. [7] demonstrated that by mixing 10 wt% Mo powder with Ti6Al4V powder, the solidification mode changes from planar to cellular and the microstructure change from the HCP α' -martensite phase to the BCC β phase. In the current paper faster solidification is considered as a grain refinement technique.

In metallurgy in general the rate at which a metal solidifies determines the size of grains after solidification [8]. The explanation is that when a metal solidifies the solidification front become unstable when the temperature in the liquid ahead of the solidification front is close to the critical temperature required for homogeneous nucleation [7]. Solute elements are redistributed ahead of the solidification front which changes the chemical composition of the surrounding liquid. The change in chemical composition reduces the critical temperature and more sites become energetically favourable for nucleation. This effect is known as constitutional undercooling. By increasing the solidification rate, less time is allowed for the chemical composition in the liquid to homogenize and constitutional undercooling become more pronounced. The use of faster scan speeds in laser powder bed fusion allows faster dissipation of the heat from the melt pool and faster solidification. Figure 1 show the effect of cooling rate on prior β -grain size when Ti6Al4V is cooled from above the melting temperature.

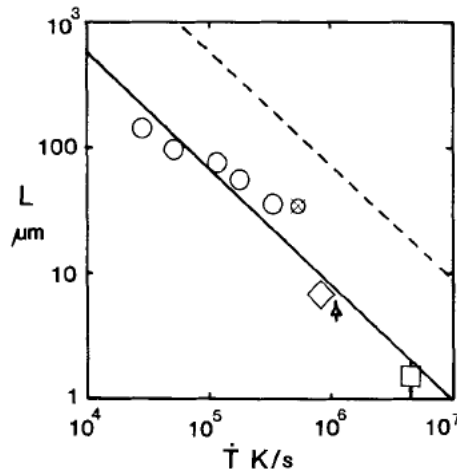

Figure 1 - Prior B-grain size (L) as a function of cooling rate when cooled from above the melting temperature

In the current paper the hardness and quarter Charpy impact toughness were measured for samples produced by a novel high power(3kW), laser powder bed fusion setup(from now on referred to as high power sample) and samples produced by a conventional 400W laser powder bed fusion machine(from now on referred to as low power sample).

2. EXPERIMENTAL METHODS

The high power samples were produced by an experimental setup at the CSIR National Laser Centre as part of the Aeroswift project. The low power samples were produced at Central University of Technology's CRPM on an EOS M280 machine. Impact testing was performed at SGS Metlab according to ASTM E23 - 12C. The impact test was repeated 3 times and the minimum to maximum range is displayed. The impact sample with the notch was machined out of a larger block after the block was removed from the base plate. See the illustration in Figure 2. Impact testing was performed in the as-built condition.

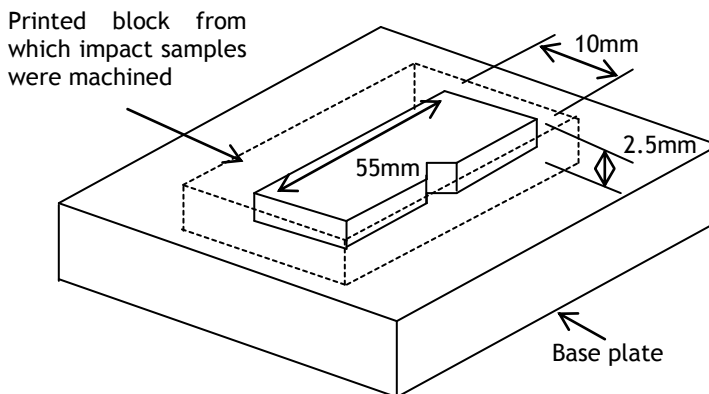

Figure 2 - Figure to indicate size of the impact sample as well as its orientation relative to the build platform

Vickers hardness testing was performed with a load of 500g and a dwell time of 15 seconds. Hardness testing was performed at 6 positions randomly spaced. The average and standard deviation are reported.

For microstructural investigation the samples were cut perpendicular to the base plate. Then the samples were ground and polished with 9 μm diamond paste, followed by 0.04 μm colloidal silica. After polishing, the samples were etched with Kroll's reagent. Pictures were taken under an optical microscope with the build direction from the bottom to the top.

The boundaries of prior β -grains are difficult to distinguish on optical micrographs. This makes it difficult to compare the prior β -grain sizes of the two samples. It was therefore decided to make crystal orientation maps from data obtained by Electron Backscattered Diffraction (EBSD). Due to the difficulty of performing EBSD on martensitic microstructures the samples were subjected to a heat treatment below the β -transition temperature which transforms the martensite to a lamellar mixture of α and β . Samples were heated at a rate of 10°C/min to 940°C, then kept at 940°C for 1h. Thereafter the samples were cooled to 650°C and kept at this temperature for 2h. All cooling rates were approximately 2.4°C/min. By making a crystal orientation map of the α -grains, some prior β -grains could be distinguished.

3. RESULTS AND DISCUSSION

Table 1 shows the measured mechanical properties of the two samples in the as-built condition as well as a milled and annealed reference sample.

Table 1: Mechanical properties

	(2.5x55x10mm) Charpy impact toughness(J)	Vickers microhardness (500g, 15s)
Low power laser powder bed fusion sample	6	360±14
High power laser powder bed fusion sample	8-10	352±14
Milled and annealed reference sample	6-8	304±12

Note that there is no significant difference in microhardness between the low power and high power samples. Secondly, note that the impact toughness of the high power sample was consistently measured to be higher than the low power sample.

Figure 3 shows optical micrographs of the two samples. Firstly, note that in both samples a martensitic phase inside columnar prior β -grains is visible. Secondly, note that the columnar nature of the prior grains is more pronounced in the high power sample.

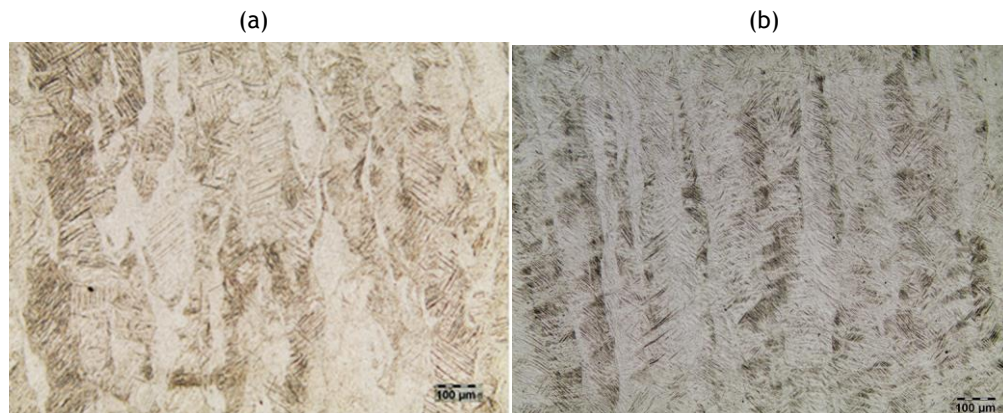

Figure 3 - (a) Microstructure of low power sample (b) Microstructure of high power sample.

Figure 4 indicate crystal orientation maps that were compiled based on the orientation of α -crystals. The black lines were manually drawn where prior grain boundaries could be distinguished. Note that in the high power sample the prior β -grains are more columnar and thinner.

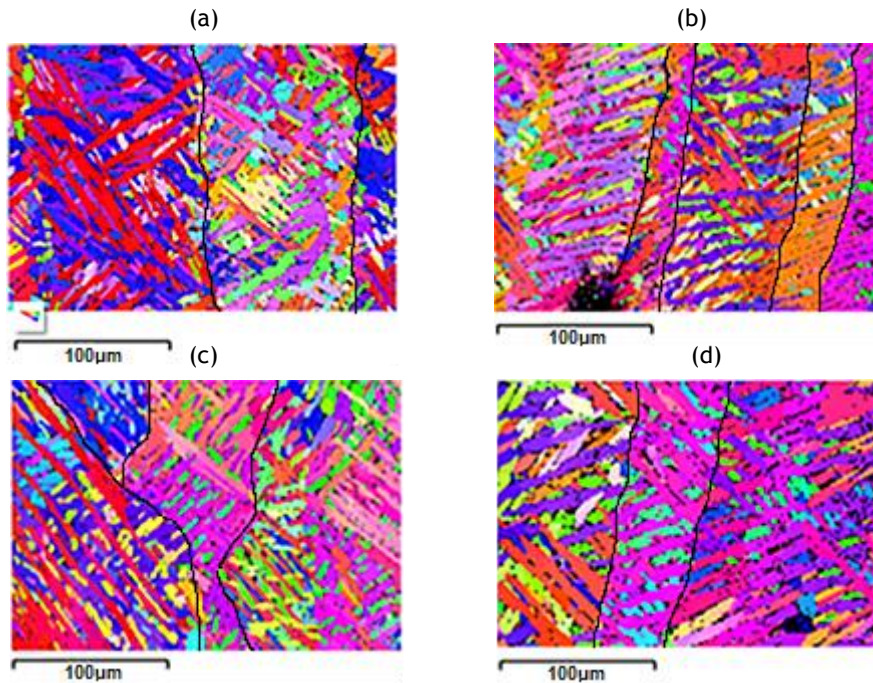

Figure 4 - Crystal orientation mapping of low power laser powder bed fusion sample (a) and (c). Crystal orientation mapping of high power laser powder bed fusion sample (b) and (d)

The fracture plane in the impact tests ran parallel to the plain on which the crystal orientation maps were made. Fracture had to cross every prior β -grain boundary in the horizontal direction. The fact that the prior β grains are narrower in the plane where fracture occurred does explain why higher impact toughness was measured.

4. CONCLUSION

The use of higher laser powers and faster traverse speed of the laser beam during laser powder bed fusion of Ti6Al4V produce a final material with higher impact toughness when the notch is cut so that the fracture plane is perpendicular to the base plate. This is explained by the narrower columnar prior β -grains observed.

5. ACKNOWLEDGEMENTS

The author would like to acknowledge discussions with Marius Vermeulen and Andries Uys from Aerosud; Duwan Bester, Herman Rossouw, Herman Burger, Charl Small from CSIR National Laser Center. The author acknowledges funding provided by Department of Science and Technology (DST) and Laboratory and equipment support from CSIR National Laser Center and Aerosud ITC. The help from Thabo Lengopeng and Khoro Malabi are acknowledged.

REFERENCES

- [1] Thijs, L. Verhaege, F. Craeghs, T. Van Humbeeck, J. Kruth, J.P. 2010. A study of the microstructural evolution during selective laser melting of Ti-6Al-4V, *Acta Materialia*, 58, pp 3303-3312.
- [2] Rafi, HK. Karthik, NF. Gong, H. Starr, TL. Stucker, BE. 2013. Microstructure and mechanical properties of Ti6Al4V parts fabricated by selective laser melting and electron beam melting, *Journal of materials engineering and performance*, 22(12), pp 248
- [3] Vrancken, B. Thijs, L. Kruth, JP. Van Humbeeck, J. 2012. Heat treatment of Ti6Al4V made by selective laser melting - microstructure and mechanical properties, *Journal of Alloys and Compounds*, 541, pp 177.
- [4] Chunlei, Q. Adkins, N. Attallah, M. 2013. Microstructure and tensile properties of selective laser melted and of HIPed laser melted Ti6Al4V, *Materials science and engineering A*, 578, pp 230-9.
- [5] Lütjering, G. 1998. Influence of processing on microstructure and mechanical properties of (α + β) titanium alloys, *Materials Science and Engineering*, A243, pp32.
- [6] Leuders, S. Thöne, M. Riemer, A. Niendorf, T. Tröster, T. Richard, HA. 2012. On the mechanical behavior of titanium alloy TiAl6V4 manufactured by selective laser melting: Fatigue resistance and crack growth performance, *International Journal of Fatigue*, 48, pp 300-307.
- [7] Vrancken, B. Thijs, L. Kruth, J. Van Humbeeck, J. 2014. Microstructure and mechanical properties of a novel Beta titanium metallic composite by Selective Laser Melting, *Acta Materialia*, 68,pp 150-158.
- [8] Kobryn, PA. Semiatin, SL. 2003. Microstructure and texture evolution during solidification processing of Ti6Al4V, *Journal of Materials Processing Technology*, 135:330, 330-339.